

**THE
HUMAN DESIGN
SYSTEM**

RA URU HU



FOREWORD

I could never have imagined what kind of extraordinary turn my life had taken, when I left Canada in the early eighties and discovered the Island of Ibiza.

This work, the Human Design System, is not the place to describe the events which led to this understanding. What is pertinent to this page, is that the Human Design System was revealed.

I was conditioned to believe that 'science fiction' was a genre of literature, that mystical revelation was simply a more antiquated form of the same, and that God, if not dead, was most likely a concept.

On the evening of January 3, 1987, all of that changed. I was 'penetrated' by a 'Voice'. It was a terrifying experience. My hair literally stood on end, in the shock, a flood of water drained from my scalp.

The Voice said, 'Are you ready to work?'

For eight days and nights, I worked, transcribing in detail the Human Design System.

Ra Uru Hu

14.10.91

Ibiza

Table of Contents

Foreword	
The Human Design System - Introduction	1
The Rave Charts	11
The Rave I Ching Astrological Index	33
The Rave I Ching	41
The Juxtaposition Unified Theory (JUT)	107
Blank Charts	123



Published by

NEW SUN SERVICES IBIZA

Copyright Ra Uru Hu 1991

No reproduction without permission. All rights reserved.

Printed in München, Germany, 1992

THE HUMAN DESIGN SYSTEM

AN INTRODUCTION

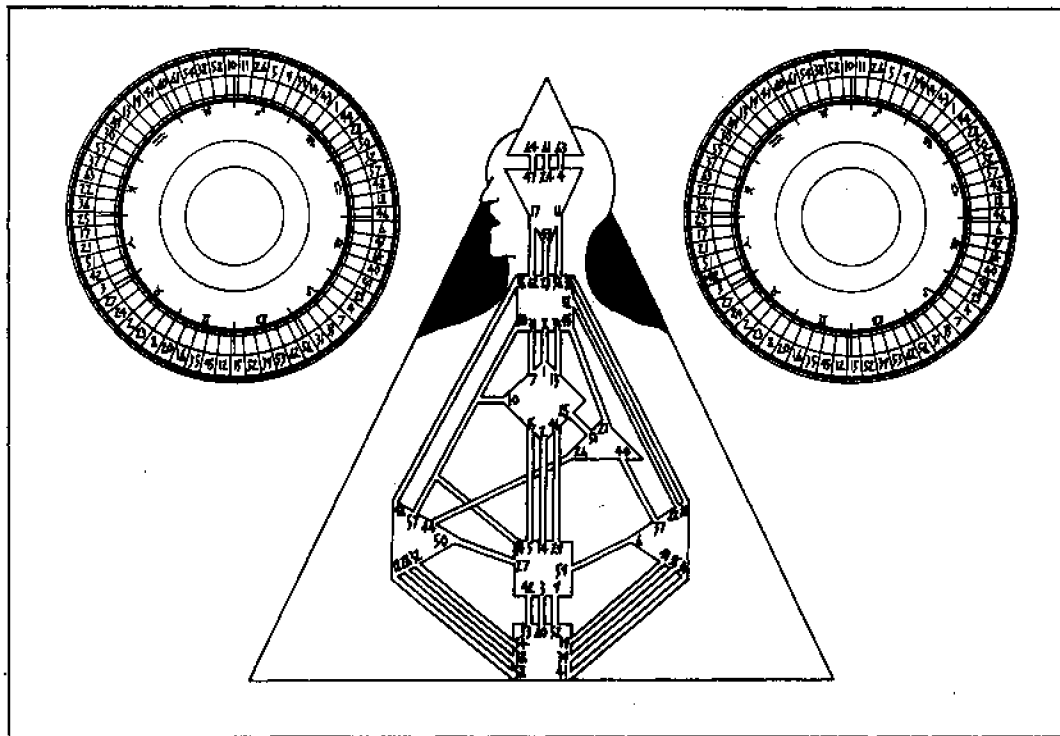

I am indebted to whatever Gods may be that I am an instrument of this knowledge. It is not mine. I have no choice.

This work is dedicated to the Sons and Daughters of Ibiza who loved, nurtured and protected me in my journey.

Questions and the pursuit of their answers is in Humankind's design. East and West, North and South, the 'Thinker' man has sought answers to the same questions. However, for most of our civilized history, geography, race and the lack of communication and transportation technology has separated cultures. Evolved generally in isolation, each culture assumed that its own answers were universal.

Today, in this last decade of the twentieth century, we live in a totally different world. 'The Global Village' is a reality. We are witnesses and participants in this planetary fusion. We have access to the largest information pool in the history of our species. We are able to travel, both physically and through our technologies, to every corner of our planet.

What we have discovered is that no single answer speaks for the planet as a whole. The result is three different approaches. The first two represent a basic duality, expansion or isolation. The ideological struggle of the Cold War is an example of expansion. The attempt through economic or brute force to impose one culture's truth on another. Isolationism is the other extreme exemplified by religious fundamentalism.

There is a third way and this is the basis of the Human Design System. It is called Synthesis. Symbolically this approach was initiated in 1969, when our planet was photographed for the first time from space. It was clear and evident that the Earth was a totality. A totality has many aspects, in which no single aspect defines the whole. A severed arm lying on a surgical table could not be called a Human Being. The premise of the Human Design System is that

each of the answers are like parts of the body. Each culture in its evolution has explored and discovered aspects of the truth. The synthesis of these diverse aspects creates a complete body of knowledge and as demonstrated by the law of mathematics, the whole is greater than the sum of its parts.

The whole is more than the Earth. The whole is the universe itself. There are many ideas and structural aspects of the Human Design System which are new. This is a work of revelation. In order to understand how the system works and can be applied, it is first necessary to become familiar with the ideas which form the background of this synthesis. It is also important to understand that there is no claim being made here of an absolute truth. Revelation is something that is shared. The Human Design System has already proven to be a valuable tool for Human understanding. The sharing of this knowledge is the only purpose of this work.

Modern physics based on the famous Relativity equation ($E=mc^2$) of Albert Einstein describes the universe as a four-dimensional field which began some fifteen billion years ago in an event called the Big Bang. According to this theory, Time began in this point called singularity. In other words, no time existed before this event.

The ancient mystics on the other hand, almost uniformly imagined the beginning as an egg. The Cosmic Egg fertilized by a God or Gods or some other supernatural force. Man's early wisdom was based on extrapolating outwards from recognized truths. As below, so above. Creation for the ancients, based on abundant evidence of life itself could not have been spontaneous.

Both awarenesses actually have a common ground, singularity. Physicists and astronomers exploring our universe have discovered that it is littered with 'eggs'. They are called rather misleadingly 'Black Holes'. These are incredibly dense objects, so dense and their gravity so powerful that they even pull back and absorb their emitting light and convert it into matter; thus its darkness.

One of the great laws of the universe is that impact initiates cosmology. Black Holes are considered the birthing ground of stars and galaxies. When these objects are struck by a strong enough force, the impact releases unimaginable energy and matter which eventually coalesce into stars. Our own Sun's solar system was born out of such an event.

Though Creation as an act is the spiritual understanding of countless generations of man, clearly, it is at odds with some of the conclusions derived from relativity. The problem is Time.

According to relativity, time began with the birth of the universe. According to the mystics, creation took place in a time before the universe. If Einstein's theory is an absolute law, then what we call the universe is spontaneous and without meaning or purpose. The Human Design System is based on seeing relativity as relative. Just as Newton's laws are relative to earth, so too, Einstein's theory is relative to the universe after the Big Bang.

In the beginning ... We start before the Big Bang. The beginning before the start had a nature. The question behind the 'who' of creation is beyond the ken of man. It is beyond the scope and design of any foetus to understand the nature of its makers. Only with birth and the emergence into the

realm of its parents does the child begin to understand its kind.

In the beginning was an egg. Physicists have calculated that at the point of singularity, their beginning, the entire mass of the universe was compressed into an object the size of a human fist! This is the egg/ovum, the mother of Black Holes, the primordial Yin. Within the horizon of this 'egg' lay the matter potential of the universe. We know that black holes release their potential via impact or in the language of eggs, through fertilization.

It is not surprising but may be amusing to note that the word 'bang' carries the slang meaning of the sexual act. Fertilization required a Seed/sperm, the primordial Yang, to initiate the event, the creation of the universe. The universe is a foetus, if you like, The Child. The Yang energy at impact ended the inertness of matter and initiated movement, the expansion of the universe. The vast potential of the egg was released. A human would call it conception. Our universe is the offspring of the event we call the Big Bang. It is us and we are it; a creation evolving, still within the womb. We are one with whatever created us, of the same kind.

In order to understand the nature of the Child and ultimately ourselves, we must begin with the basic components. These components are both mystical and scientific.

Physics acknowledges five forces in the universe. These forces are the field for the two great families of things spawned at the Big Bang. They are the Quarks and the Leptons, the design duality of the universe.

In the beginning there were six Quarks, Up, Down, Strange, Charm, Beauty and Truth. (The latter two are sometimes referred to as Top and Bottom.) The Quarks divided into two groups of three each. We call these groupings, Proton and Neutron. The Proton and Neutron form the center, the nucleus of the atom.

In the beginning there were also six Leptons which also divided into two groups, the Electrons and Neutrinos. The Electrons formed a polarity union with the Proton/Neutron and the Atomic universe, our world of stars and trees and you and me could manifest. Everything that we think of as the universe, from the sky above to the sea below is atomic in nature.

The Neutrino, however, is a special case. It is by far the most abundant of all the particles. Atomic material actually accounts for a mere ten percent of the mass of the universe. The vast unseen mass, known popularly as Dark Matter, is Neutrino. There are three kinds of Neutrinos, the Electron Neutrino, the Muon Neutrino and the Tau Neutrino. They possess an infinitesimally small amount of mass and are manufactured in stars. Three trillion Neutrinos penetrate through everything, everywhere, every second at the speed of light. In fact, the universe itself is a vast Neutrino web/grid. The body of the Child.

The Neutrino is of enormous significance to man. Like everything else, we are constantly being penetrated. Since Neutrinos have mass, as the stream passes through us, through the planet, it leaves off information. It is a data stream and within each of us exist particles which connect us to the stream.

The last essential scientific component is the Magnetic Monopoles. The monopole is a theoretical concept of physicists. It is in essence a magnet, but one with only one pole. It only attracts and has no capacity to repel.

These components, the Atom, the Neutrino and the Magnetic Monopole manifest our universe of forms. It is the 'Crystals' which give the forms substance.

In the beginning there were two Crystals. The Yang Crystal within the seed and the Yin Crystal within the egg. At conception when the Yang banged into the Yin, the Crystals shattered on impact and spread out into the expanding universe. It is these Crystals which are at the core of what we call life. This is necessarily symbolic language. Like the magnetic monopole of the physicists the existence of such Crystals has not been proven.

This is a mystical component and the term Crystal best expresses these particles and how they function. A Crystal will shatter into many facets. Each facet is unique. When the original Crystals shattered untold numbers of facets streamed out from the impact. There is a facet from each of the original two Crystals in every Human Being. (They are also present in all forms of life.)

These five components provide us with the background upon which the Human Design System is based. Man in his pursuit of understanding has developed systems as tools for organizing information and knowledge. The Human Design System based on the above components synthesizes two great families of systems.

The older family is the Esoteric Systems. These are ancient

sciences based on thousands of years of observation and analysis. The other family is the modern sciences based on several hundred years of observation utilizing advanced technologies.

The Human Design System is about diversity finding harmony through synthesis. The field for this synthesis is the Rave Chart. The Rave Chart incorporates the I Ching, the Book of Changes from China; the Chakra energy system and Lunar Astrology from India; Arabian Stellar Astrology; the Kabbalah; Western Astrology; Physics; Astronomy; Biology; and Chemistry.

We can now begin to put all this diversity into perspective. We have seen that the Big Bang was a form of conception, that our universe is a living evolving organism. It is the contention of the Human Design System that the life force of our planet is the manifestation of its developing consciousness. The destiny of the 'Global Village' IS in fact, the global Mind.

A Human Being is an aspect of this consciousness, enclosed in an evolved Atomic Bio-Chemical vehicle. The consciousness is not the vehicle. The vehicle is the life. A Human, as well as other higher life forms, is endowed with two sub/sub-atomic Crystals and one Prime Magnetic Monopole through which its being is manifested.

Just beneath the scalp on the crown of the head is a Yang Crystal, which we will henceforth refer to as the Personality Crystal. This is the crystal of consciousness. It is who you think you are. The Witness. It cannot choose. It has no choice. It is not the body. It is the personality.

It has no choice. It is not the body. It is the personality.
It communicates. It is the mind and it remembers.

Between the eyes, beneath the brow is a Yin Crystal which we will henceforth refer to as the Design Crystal. It is the life. It is the body and the body is what you think and say and do. It is the coordinator of your physical development. It is being. It is the ego and its designs.

We have lived for centuries with a great lie, 'that all men are created equal'. It is not so, that we all know. The truth is that we are all created 'unique'. Each crystal facet represents a unique aspect of the totality. Imagine these crystals as diamonds. If you put the same light source through two differently cut diamonds, the result will be two unique patterns of light. This is the vast diversity of Humankind. Billions of crystals all penetrated by the same source, the neutrino stream, that passes through these crystals programming life and art and dreams.

In the chest, where the rib cage separates is a Prime Magnetic Monopole. It only attracts. It aligns us to our geometry and our geometry is our individuality. Together these three components can be simply understood through the example of a limousine. There is a driver, the Monopole. It knows where it is going. There is the vehicle, the Design Crystal. It goes; and there is the passenger, the Personality Crystal. It goes along for the ride.

As I have stated, the Earth is the environment for the developing consciousness of the Child. Within its atmosphere and within its core are untold billions of crystals. Personality Crystals move within the outer shell, clusters of which have been historically perceived as ghosts, angels,

The Crystals and the Monopole

The Personality Crystal

The Witness

Who you think you are.
Located in the Head Center.
It manifests as a binary:

1. The Personality
It is Space. Space is Form.
Form is Illusion. Illusion is
Hearing. Hearing is Music. Music
is Freedom.

Keynote: I Communicate

2. The Mind
It is Evolution.
Evolution is Gravity.
Gravity is Memory. Memory is Taste.
Taste is Love. Love is Light.

Keynote: I Remember

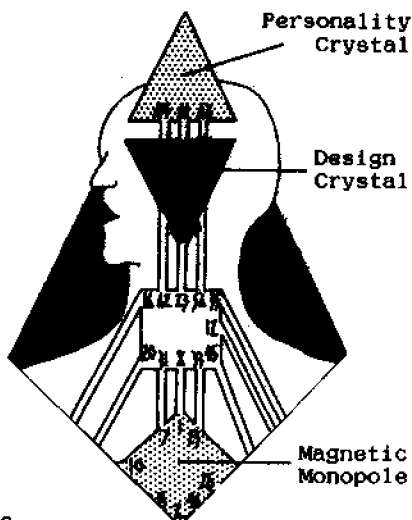

The Design Crystal

The Vehicle

What you say and think and do.
Located in the Ajna Center.
It manifests as a binary:

1. The Body
It is Being. Being is Matter. Matter is. Matter is Touch.
Touch is Sex. Sex is Survival.

Keynote: I Am

2. The Ego
It is Design. Design is Structure. Structure is Progress.
Progress is Smell. Smelling is Life. Life is Art.

Keynote: I Design

The Magnetic Monopole

The Attractor.

Your Uniqueness.
Located in the G Center:

1. Individuality
It is Movement. Movement is Energy. Energy is Creation.
Creation is Seeing. Seeing is Landscape. Landscape is
Environment.

Keynote: I Create

UFOs and other so-called supernatural phenomena. Design Crystals cluster in the Earth's core and each is embedded with a Prime Magnetic Monopole.

At the moment of union between Man and Woman: remember that there is no choice. A life emerges when it should. If there is to be conception, the Magnetic Monopole of the male attracts a Design Crystal from the Earth's core. At the moment of orgasm, when millions of sperms enter the uterus, it is only the sperm bearing the attracted Design Crystal that will penetrate the ovum. Life begins as a trinity, sperm/ovum/Design Crystal.

It is the Design Crystal which controls the development of the new life. As the stream of Neutrinos penetrates the Mother and her Crystals, they also penetrate the Design Crystal of the foetus. It is the Design Crystal which manages the bio-chemical nature. For approximately the first six months of the pregnancy, the Design Crystal and its Magnetic Monopole function alone in the foetus, translating the Neutrino stream, uniquely filtering the data. As will be illustrated later, the Crystal transfers these data to the body's nine energy centers and from the energy centers to the glands and from the glands to the developing organs.

At the end of the second trimester, approximately six months (exactly 88 degrees of the Sun's movement before birth) the Magnetic Monopole of the foetus attracts a Personality Crystal from the environment into the womb. It is only at this point that the Personality Crystal has an environment (the Brain) in which it can begin to function. In this way a human life comes into existence.

The Human Design System is illustrated through the three

types of Rave charts. The Rave chart allows us to map individual Human design, providing the knowledge to understand one's nature, potential and daily interaction with the universe. We have seen that the components which make up the Human Design System are diverse. Astrological methodology is one of these components. The Rave chart of an individual is composed of two wheels and a body graph. The Wheel is an ancient device for measuring the movement of the planets and the sun. With the Earth in the center of a circle of 360 degrees, we are able to accurately measure the movement of the planets relative to ourselves.

In understanding the Neutrino stream, one can begin to grasp the basic integrity of the idea underlying general astrology. In our modern scientific understanding, it is acknowledged that every object effects every other object, but astrology has always claimed that specific objects, the planets, have particular and enduring effects. This idea is reinforced by the Neutrino. As an example, at the moment of a birth, Mars will be in a specific position. Like everything else, Mars the planet is penetrated by the stream. Since the Neutrino stream has a mass, it will have a friction experience with the substance of Mars as it passes through. This interaction will change the nature of the stream, so that when it passes through a Human Crystal, it will leave off this altered data. In this way Mars makes its imprint on the emerging life, in fact, not theory.

Our Sun, by the way, a star, produces over seventy percent of the Neutrinos we receive. Its astrological importance has not been overstated.

The Wheels used in the Rave Charts have the traditional

zodiacal configuration on the inside, the twelve signs of thirty degrees of arc each. On the outside are the sixty-four Constellations/Hexagrams of the I Ching. Each Constellation/Hexagram takes up 5°37'30" of arc. These divisions divide the circle into specific fields of energy.

The Western Zodiac:

Aries
Taurus
Gemini
Cancer
Leo
Virgo
Libra
Scorpio
Sagittarius
Capricorn
Aquarius
Pisces

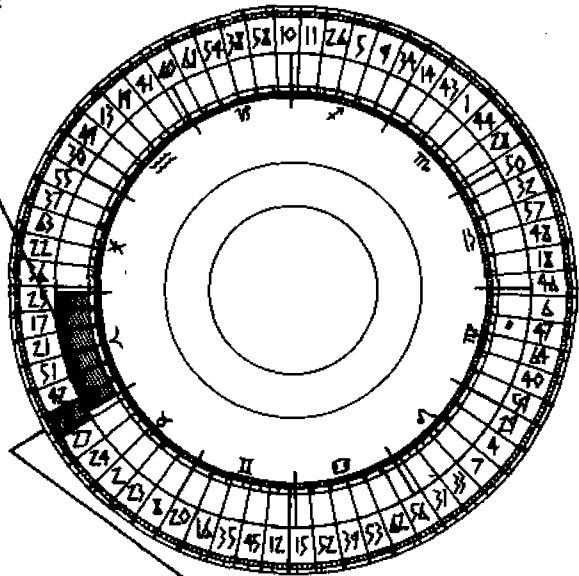

The Hexagrams:

1. The Creative 2. The Receptive 3. Difficulty at the Beginning 4. Youthful Polly 5. Waiting 6. Conflict 7. The Army 8. Holding Together 9. The Taming Power of the Small 10. Treading 11. Peace 12. Standstill 13. Fellowship of Man 14. Possession in Great Measure 15. Modesty 16. Enthusiasm 17. Following 18. Work on What Has Been Spoilt 19. Approach 20. Contemplation 21. Biting Through 22. Grace 23. Splitting Apart 24. Returning 25. Innocence 26. The Taming Power of the Great 27. Nourishment 28. Preponderance of the Great 29. The Abyssmal 30. Clinging Fire 31. Influence 32. Duration 33. Retreat 34. Power of the Great 35. Progress 36. Darkening of the Light 37. Family 38. Opposition 39. Obstruction 40. Deliverance 41. Decrease 42. Increase 43. Breakthrough 44. Coming to Meet 45. Gathering Together 46. Pushing Upward 47. Oppression 48. The Well 49. Revolution 50. The Cauldron 51. The Arousing 52. Keeping Still 53. Development 54. The Marrying Maiden 55. Abundance 56. The Wanderer 57. The Gentle 58. The Joyous 59. Dispersion 60. Limitation 61. Inner Truth 62. Preponderance of the Small 63. After Completion 64. Before Completion

In the Rave I Ching, which follows this introduction, can be found a detailed reference to the meaning of each of these fields of energy. What is important to understand at this stage is that when the position of an object is calculated, it can be transposed to the Wheel. Each calculation will place a planet in a general zodiacal sign and more specifically in one of the sixty-four Constellations/Hexagrams.

The Rave chart diverges greatly from the format of general astrology. To begin with, there are two wheels used in the Rave chart as opposed to one in astrology. There is a wheel to calculate the nature of the Design Crystal and the other to calculate the nature of the Personality Crystal.

Traditional astrology calculates its wheel for the exact time of birth and location. In the Rave chart this is the calculation used for the Personality Crystal only. The Wheel of the Design Crystal is a calculation made three months before birth. It is the contention of the Human Design System that the traditional Natal chart can only represent the potential of the personality and therefore, its limitation.

These two wheels are not ends in themselves. They act as an information base to reveal the integrated design of personality and body. The key is the sixty-four Hexagrams.

The Rave is made up of two wheels and a triangle. The triangle is the integrating field, the Body Graph. The Body Graph illustrates the basic Human circuitry. Its design incorporates three traditional systems. Firstly, the Hexagrams. They are the key for transferring the information from the Wheels to the Body Graph. The Body Graph (next page for an illustration) is based on the Chakra system. The Rave

Body Graph has nine centers. These centers are connected to each other through thirty-two channels (based on the Sepiroth of the Kabbalah).

The nine centers possess in total sixty-four Gates which open up potential connections between centers through the channels. When a position of a planet is calculated for one of the wheels, placing it in a specific Hexagram, this information can then be transposed to the Body Graph. Each Hexagram represents a specific field of energy, literally a Gate, which when activated opens. Once all the calculations are made and transposed to the Body Graph the integration of the Design and the Personality unfolds. This is then the basic Human design.

In the Human Design System there are nine centers. Each center or Chakra coordinates information from the Crystals and then transfers this information to the Glands. This system of transference allows the Neutrino stream to be translated into the chemical language of our bodies.

The Centers:

1. The Head Center: Inspiration, initiation and undergoing operating through the Pineal Gland.
2. The Ajna Center: Knowing, intuition and understanding operating through the Anterior and Posterior Pituitaries.
3. The Throat Center: Action, metamorphosis and unfolding operating through the Thyroid and Parathyroid Glands.
4. The Heart Center: Ego, zeal and passion operating through the Thymus Gland.

The Rave Body Graph

The Centers. The Hexagram Gates and the Channels

Example:

A Center - the Head Center

A Channel 64-47

Abstraction

A Gate - 47 Oppression

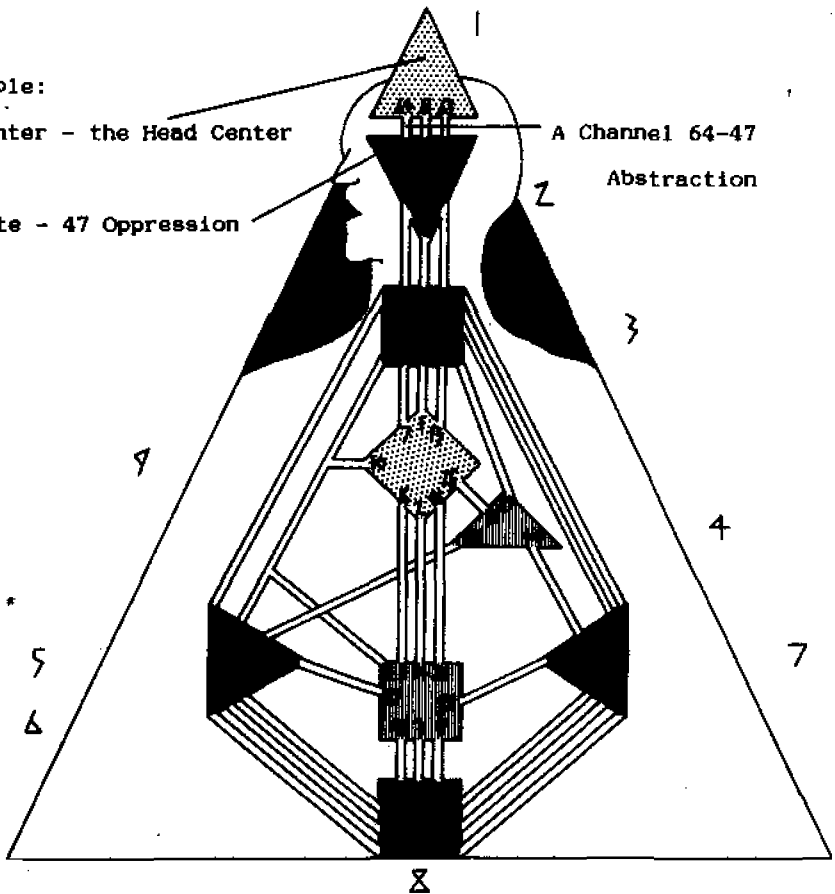

The colours: 1. Head Center - yellow; 2. Ajna Center - green;
 3. Throat Center - brown; 4. Heart Center - red; 5. Splenic
 Center - brown; 6. Sacral Center - red; 7. Solar Plexus
 Center - brown; 8. Center at the Base of the Spine - brown;
 9. G. Center - yellow.

5. **The Splenic Center:** Balance, judgment and cleansing operating through the Spleen and Lymph System.
6. **The Sacral Center:** Maturation, reproduction and sexuality operating through the Ovaries and Testes.
7. **The Solar Plexus Center:** Aspiration, sensitivity and emotion operating through the Kidneys and Pancreas.
8. **The Center at the Base of the Spine:** Assertion, energy and evolution operating through the Adrenal Glands.
9. **The G. Center:** Spirituality, gravity, attraction and love operating through the Liver.

As discussed earlier, the Centers are hubs in an energy circuitry. This circuitry is the Rave Body Graph Channels. A channel is a connective medium between Centers..

Each channel modifies and focuses the energy that passes through it. Theoretically, though not generally, a Human Design can have a maximum of twenty-six gates opened among the sixty-four. It is normal to have a balance between Centers that are permanently connected by design and those that are partially opened or not opened at all, and can only be connected through the influence of the planets or others. The following is a list of the Channels and their keynote description. As with the Hexagrams and the Centers, the Channels are explained in greater detail in the Rave I Ching which follows this introduction.

The Channels and their keynotes:

Between the Head and Ajna Centers

- 64-47 Abstraction A design of mental activity and clarity
- 61-24 Awareness A design of a thinker
- 63- 4 Logic A design of mental ~~ness~~ mixed with doubt

Between the Ajna and Throat Centers

- 17-62 Acceptance A design of an organizational being
- 43-23 Structuring A design of individuality
- 11-56 Curiosity A design of a searcher

Between the Throat and Splenic Centers

- 16-48 The Wave Length A design of talent
- 20-57 The Brain Wave A design of penetrating awareness

Between the Throat and Sacral Centers

- 20-34 Charisma A design where thoughts must become deeds

Between the Splenic and the Center at the Base of the Spine

- 32-54 Transformation A design of being driven
- 28-38 Struggle A design of stubbornness
- 18-58 Judgment A design of insatiability

Between the Throat and the G. Centers

- 20-10 Awakening A design of commitment to higher principles
- 31- 7 The Alpha For 'good' or 'bad', a design of leadership
- 8 - 1 Inspiration The creative role model
- 33-13 The Prodigal The design of the witness

Between the G. and Sacral Centers

- 10-34 Exploration A design of following one's convictions
- 15- 5 Rhythm A design of being in the flow
- 2 -14 The Beat A design of being the keeper of keys
- 46-29 Discovery A design of succeeding where others fail

Between the G. and the Splenic Centers

- 10-57 Perfected Form A design of survival

Between the Splenic and the Sacral Centers

- 57-34 Power A design of an archetype
- 50-27 Preservation A design of custodianship

Between the Throat and the Heart Centers

- 45-21 Money A design of a materialist

Between the Sacral and the Solar Plexus Center

- 59- 6 Mating A design focused on reproduction

Between the Sacral and the Center at the Base of the Spine

- 42-53 Maturation A design of balanced development, cyclic
- 3-60 Mutation Energy which fluctuates and initiates, pulse
- 9-52 Concentration A design of determination, focused

Between the Heart and Splenic Centers
 26-44 Surrender A design of a transmitter

Between the G. and Heart Centers
 25-51 Initiation A design of needing to be first

Between the Heart and Solar Plexus Centers
 40-37 Community A design of being a part, seeking a whole

Between the Throat and Solar Plexus Centers
 35-36 Transitoriness A design of a 'Jack of all Trades'
 12-22 Openness A design of a social being

Between the Solar Plexus and the Center at the Base of the Spine
 49-19 Synthesis A design of being sensitive
 55-39 Emoting A design of moodiness
 30-41 Recognition A design of focused energy

At this point we have covered the ideas behind the Human Design System and the components which make up its structure. Like all systems the information base is complex. It is only through the utilization that the components become understandable. In part two of this introduction the process for making an individual Rave chart will be described; it will outline in detail how the chart once calculated actually works, and how to use it.

The Individual Rave Chart

The Wheel of the
Design Crystal

The Body Graph

The Wheel of the
Personality Crystal

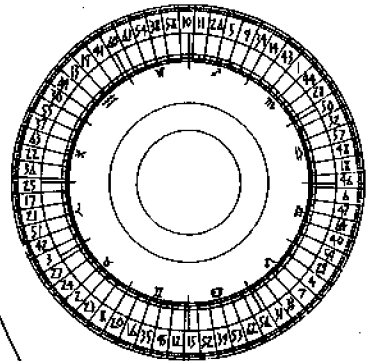
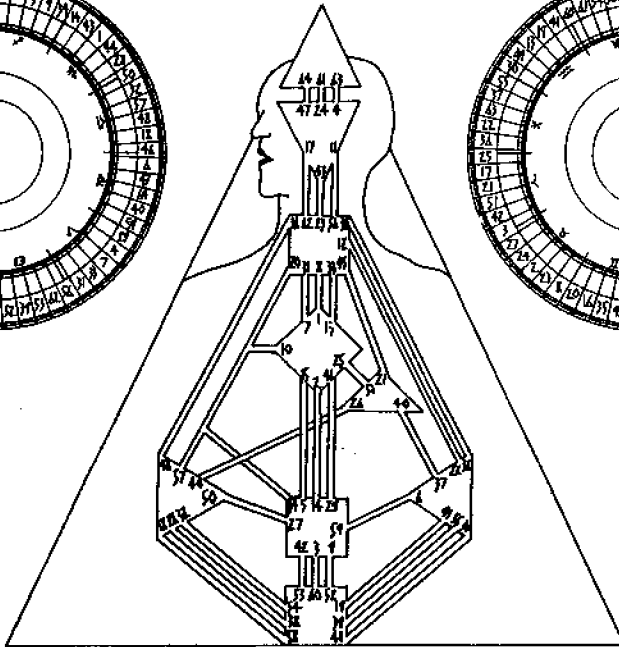
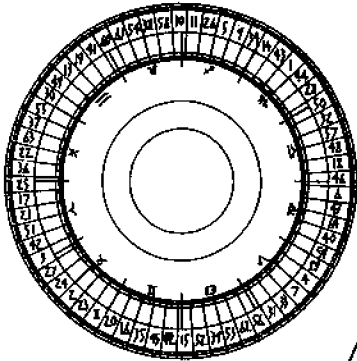

The Rave Charts

There are three different types of Rave charts; the Individual Rave, the Composite Rave and the Daily Rave. The Rave is a tool for revealing design. Each of these Rave charts are essential to capture and understand how our lives work.

Of foremost importance is the Individual Rave. It is a map to one's own design and reveals clearly how one connects to the world. On the opposite page is an example of an Individual Rave chart.

As discussed earlier and as you can see, there are two wheels, one on either side of a Body Graph. The wheel to the left of the Body Graph is the Wheel of the Design Crystal. The wheel on the right of the Body Graph is the Wheel of the Personality. The Body Graph is the integrative field for the information derived from these two wheels.

Anyone capable of calculating an ordinary astrological chart can easily plot a Rave. For those who are unable to do so, any astrological computer service can provide you with quick and accurate calculations inexpensively. These services exist in all major centers. In addition, this publisher will provide completed Rave charts through the mail (details can be found in the Appendix at the back of this book).

The Rave is based on two sets of calculations, one for each of the wheels. The wheel on the right, the Personality Wheel is calculated in the same manner as a normal astrological chart. It is necessary to know the exact time, date and place of birth. (If you do not know your exact time of birth, generally the hospital records contain this information or at your local birth registry office.)

With this information and an astronomical ephemeris (an ephemeris is a scientific compilation of the exact position of the planets for each day of any year) one can calculate the exact position of the planets at your time of birth. This information can then be transposed to the Personality Wheel.

The position of all the planets (♃ Mercury, ♀ Venus, ♂ Mars, ♃ Jupiter, ♄ Saturn, ♅ Uranus, ♆ Neptune, ♇ Pluto), the Moon ☾ and its ♀ North and ☽ South Nodes, and the Sun ☉ and the Earth ⊕ are plotted. The Planets each represent a different kind of energy. It is important to have a basic understanding of their effect. They qualify how each of the opened Gates is interpreted. The following is a list of the Planets and their traditional meanings. As with the other keynote information presented in this work, the Planets have been studied since the beginning of civilization, serious students interested in detailed information have access to thousands of books on these subjects.

The Planets

☉ The Sun	Vitality Power Will The Ego Leadership
⊕ The Earth	Fertility Evolution Design The Root
☾ The Moon	Feelings Instincts Change The Body
♀ North Node	The line of Geometry. Where you are going
☽ South Node	The line of Geometry. Where you came from
☿ Mercury	The Mind Awareness Communication Mental Life
♀ Venus	Art Aesthetics Values Relationships
♂ Mars	Energy Power Desire Assertion Aggression
♃ Jupiter	Expansion Opportunity Material matters
♄ Saturn	Limitation Restraint Discipline Focus Pain
♅ Uranus	Transition Revolution Instability Electricity Invention
♆ Neptune	Imagination Psychic phenomena Confusion Drugs
♇ Pluto	Regeneration Compulsion Renewal The Unconscious

This is perforce a very basic list, but it is sufficient to give you the general significance of the Planets' effect on

interpreting a Gate. The calculations for all these positions is given in degrees of arc. A circle has 360 degrees of arc. The twelve astrological signs each measure 30 degrees of arc. All positions are calculated according to the traditional zodiac. Once these calculations are done then the appropriate Hexagram can be located.

There are 64 Hexagrams which each measure 5°37'30" of arc. The degrees for each Hexagram are listed under the Hava I Ching Astrological Index, page 33. The final step is to place the symbols of the planets in their rightful Hexagram.

Once all the information has been transferred to the Personality wheel, the next step is to do the calculations for the Design wheel. You will remember that in terms of the Human Design System, the foetus for the first six months only is endowed with a Design Crystal and its Prime Magnetic Monopole. There is no Personality Crystal. It is the Design Crystal which is responsible for the development of the physical being. The first six months is when the Human animal comes into being.

The calculation for the Design wheel is based on the position of the Sun. The Sun travels around the entire 360° wheel in one year (approximately one degree of arc a day). When the position of the Sun has been calculated for birth (the Personality wheel; in the example given, J's Sun is at 29°34' Cancer) then the position of the Design Sun can be found by going back exactly 88° of arc. This is approximately three months before birth. Therefore if you travel in time from J's birth at the end of Cancer exactly 88 degrees, you will arrive at 01°34' Taurus ☉ .

Example: Johannes, born 23/7/1946 13:20 L.S.T. Germany

Calculation for the Design Crystal

Calculation for the Personality Crystal

Position Hexagram

Position Hexagram

⊙ 01°34' ♂	3
⊕ 01°34' ♀	50
♃ 23°35' ♀	12
♂ 23°35' ♀	11
♄ 05°46' ♀	58
♃ 04°23' ♀	17
♂ 21°15' ♂	23
♃ 29°46' ♀	56
♃ 21°21' ♀	32
♂ 18°52' ♀	53
♂ 14°58' ♀	35
♂ 06°36' ♀	18
♂ 09°23' ♀	33

⊙ 29°34' ♀	56
♂ 29°34' ♀	60
♂ 18°43' ♀	45
♂ 18°43' ♀	26
♂ 14°29' ♂	2
♂ 15°56' ♀	7
♂ 10°43' ♀	40
♂ 19°11' ♀	47
♂ 19°35' ♀	57
♂ 28°34' ♀	56
♂ 20°02' ♀	45
♂ 06°11' ♀	18
♂ 11°00' ♀	33

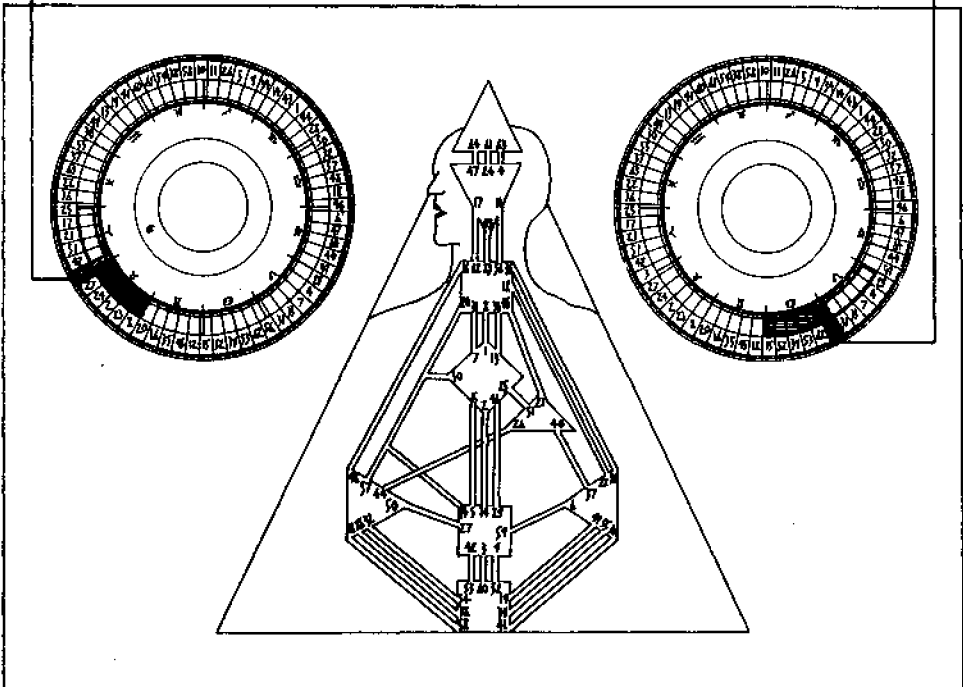

This will be the position of the Design Sun, and all other calculations will be based on this position. In astrological terms it can be referred to as a 'Solar Regression'. Again, this is a calculation that any computer service can provide. It is to be stressed that the Planets are more than objects being positioned. They are major players in the system. At this stage, when the Rave can be assembled and the interpreting begun, understanding the nature of the Planets and their effects, makes clear how the program effects you. Mercury will modify the interpretation of the opening of a Gate, by limiting it to the mental field, whereas Venus will place a relationship oriented slant on the very same opening.

With both the Design and Personality wheels calculated, now the final and most satisfying work can be done; the transference of the data to the Body Graph. Each wheel has its meaning but it is only when the information is integrated into the Body Graph that a clear picture of the overall design emerges. The Body Graph is the most important tool for analysis in the Human Design System.

It is not enough to understand the personality to the exclusion of a design. The example is the fat lady who dreams of being a ballerina. The personality may be light but the design is the determining factor. And more, the design and personality become a third thing when integrated together. They become the design of a living conscious being.

The transference is a simple process. We have now a set of calculations which place all of the planets in specific Hexagrams. These Hexagrams are numbered 1-64. The Body Graph as discussed earlier has nine centers connected via sixty-

four Gates. These Gates and the Constellations/Hexagrams of the wheels are identical. Continuing with our example of Johannes, his Sun at the time of his birth was 29°34' Cancer. This position placed his Personality Sun in the 56 Hexagram. All that is necessary to complete the transference is to fill in half the channel opened from the 56 Hexagram in the Throat Center.

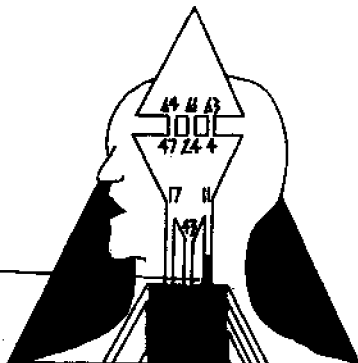

Using this simple method, all the positions from both the wheels can be transferred and the Human Design will then be revealed. A visual key for easy reference is to fill in the channels from the two wheels in different colours, for instance black and pink. It will become important, as you will see, to know from which Crystal a Gate is opened. Channels opened from the Personality Crystal will differ in interpretation from Channels opened from the Design Crystal. Here follows the finished Rave of Johannes: all the information from the two wheels has been transferred to the Body Graph. You will note that where a channel is open from both ends the Centers which it connects are coloured in. (The colours of the Centers are shown at the beginning of the Rave I Ching, page 33.)

The Rave of Johannes

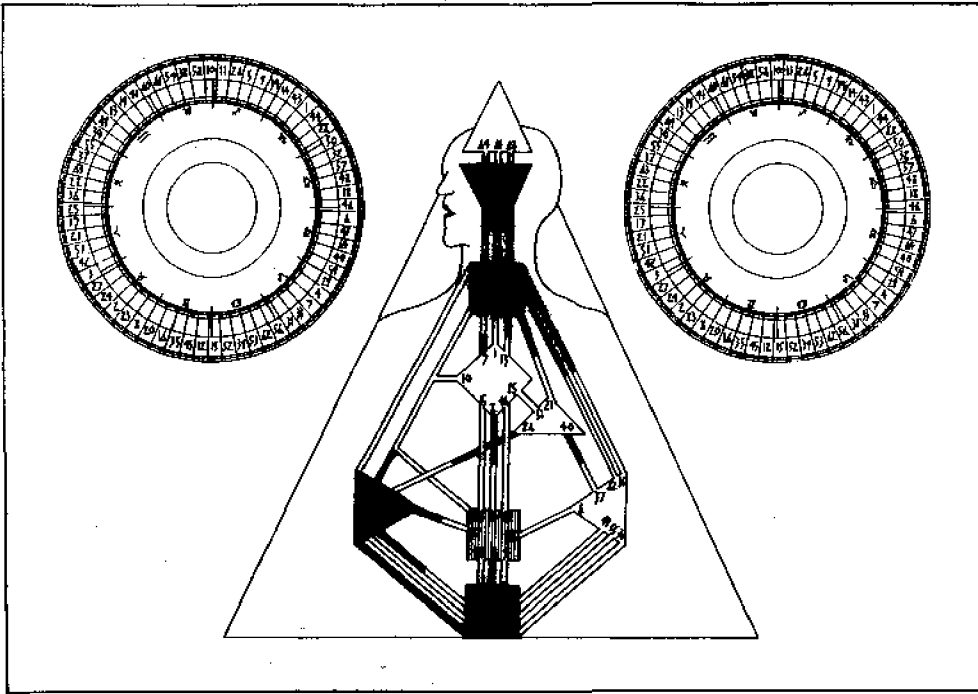

A Human Being is a balance between what is defined, permanently connected centers and what is receptive, the partially opened channels or the channels not opened at all. This will be discussed in detail in the interpretive section of this introduction.

The key to understanding a life is knowing the connections. Just as the Neutrino stream penetrates and defines our design, the process does not stop at birth. The Neutrino stream is constant and ever present. As long as there is any star in the sky and as long as our own Sun shines, there will be Neutrinos.

The second type of Rave is the Daily Rave. The Neutrino stream penetrates the planets as they penetrate us. The planets move and as they move they pass through different energy fields. These fields we call constellations or in the case of the Rave Hexagrams. Thus as the planets move in their tempos they open and close Gates. The pattern is changing all the time. This is how life changes for us. As an example, Johannes has the 57th Gate open in his splenic center. The Hexagram 57 is called the Gentle. In the ancient lan-guage it was about the penetration of the wind. The 57th Gate is about clarity. This Gate can connect to the throat center through the 20th Gate. The Hexagram 20 is called Contemplation. The connecting of the two is obvious. Con-templation leading to clarity, but in Johannes' case it is not connected.

The planets move at different speeds around the circle. The Moon opens and closes every Gate in the system, every twenty-eight or twenty-nine days. In Johannes' case the Moon will approximately once a month for about half a day make that connection. This is the program. The Moon enters Gemini and opens the 20th Gate and suddenly Johannes makes sense out of a puzzle. The Moon does not stand still. Johannes' puzzle solving will be limited. This is how life works and changes. The outer planets move very slowly relative to the Moon. Pluto, the furthest planet from the Sun will stay in a Hexagram for approximately three years. If in Johannes' lifetime that occurred, for three years he would possess an unusual ability to understand. It would however, also pass. The Artist understands this as the Muse. It comes and it goes.

Here is an example of a Daily Rave Body Graph. Based on ephemerides data of the exact position of the planets on a given day and transposed to the Body Graph. The Body Graph illustrates clearly the energy fields opened by the planets in their daily motion.

Wednesday August 21, 1991

- ☉ 29
- ⊕ 30
- ☾ 58 38 54 61

- ∩ 54
- ∪ 53
- ♁ 29
- ♂ 59
- ♂ 6
- ♂ 29
- ♂ 60
- ♂ 38
- ♂ 38
- ♂ 1

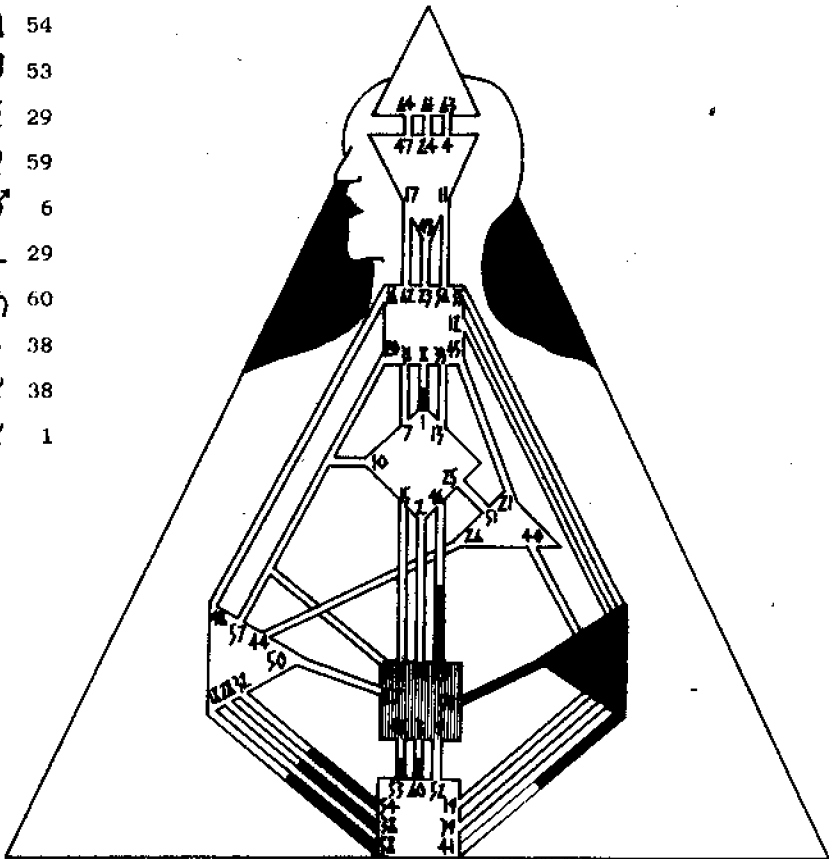

The Body Graph from an individual Rave Chart when superimposed over the Body Graph of a Daily Rave reveals clearly how the individual will be effected by the energy of the day. (Available from this publisher is The Rave Ephemeris of Body Graphs. The Rave Ephemeris provides a detailed map of the daily program. For each day, the exact position of the planets and their corresponding Hexagram and Line are given. All the information is then transposed to a Daily Body Graph. With the Rave I Ching, which follows this introduction, all of this data can be referenced and understood.)

The third type of Rave chart is the Composite Rave. It is through the Composite that the actual process of being is revealed. We are always connecting, to the planets and to others. The Daily Rave is the foundation. We always wake up to a new day. To see how we connect (or if we connect at all) is to understand what kind of patterns will condition our day's experience.

This is not soothsaying. It is not the purpose of the Composite to predict the future. The value of the Composite is to understand how the way you will experience is altered from your definition. As an example, on the following page is the Composite Rave of Johannes and August 21, 1991. We discussed earlier that Johannes' Solar Plexus Center, his emotion center is unconnected. As you can see in the Daily Rave, the only defined pattern of energy for this date is the connection between the Sacral Center and the Solar Plexus Center; from the 59th Gate, Dispersion opened by Venus (Relationships) to the 6th Gate Conflict opened by

Mars (Energy). The channel is Mating. This is the channel of fertility, sexual reproduction and mating.

When the Rave of Johannes is integrated with the Daily Rave, the most obvious change of pattern is the opening of Johannes' emotional center. For Johannes who is by design so sensitive and vulnerable to emotional change, the awareness that this energy is going to affect him, can allow him to handle it better. These patterns cannot be changed but we can experience them differently. If Johannes can see that his emotional cycles are predictable and external, he can feel better about himself. The emotional outburst that in the past might have brought self-recrimination or guilt can be seen from another perspective. It is not Johannes' fault that he is designed to be vulnerable to emotional connections. There is in fact no blame that can be attached to his responses to that energy.

The Human Being is a duality in a dualistic world. This duality defines the world in black and white, up and down, and right and wrong. From the perspective of the totality, there is no duality. It is a fact that everything we think and say and do is initiated in our bio-system one half second before we are aware of it. To understand this is to understand Shakespeare when he wrote, 'that all the worlds' a stage'. Or when Buddha said, 'The body is not yours'. We are not creative beings. It is our ego that tells us that it is all up to us.

If Johannes believed that all his emotional transitions were his doing, it could lead to a life of mental anguish, punishing himself for not understanding why he is the way he is and why he can't change it.

The Composite Rave of Johannes ●
and August 21, 1991 ●

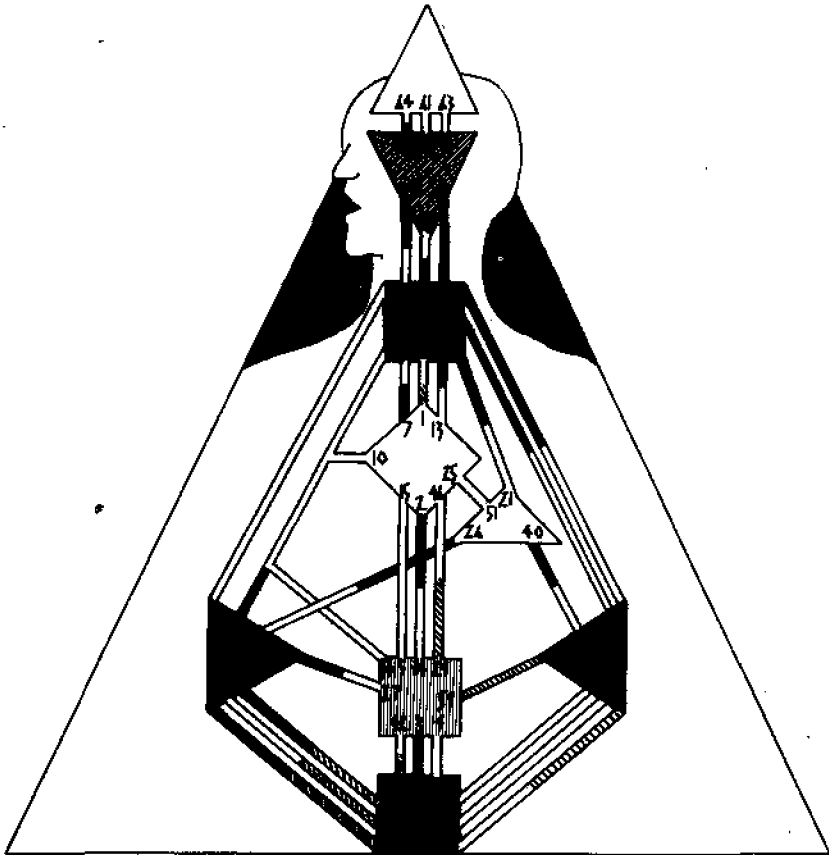

Since each Human Design is unique, how it connects to the daily program will differ from being to being. In the example given, only three of the Gates opened by the planets will directly affect Johannes during this day. Other designs will connect differently. The example of the Mating Channel (6-59) is a case where an entire channel is opened by the program. The other kind of connection can be seen on the lower left side of the Composite Rave.

For August 21, 1991, the North Node of the Moon is opening the 54th Gate in the Center at the Base of the Spine and connecting through the Transformation Channel to the 32th Gate opened by Johannes' Design Jupiter in the Splenic Center. The basic meaning of this circuit is interaction (Hexagram 54) and Duration (Hexagram 32 - the only thing that endures is change); becoming transformation.

The energizing of the cleansing center acts as a balance to the opening of the emotional center. In this case the emotional field can lead to a transformation of understanding. Like all knowledge understanding is derived from the whole picture. Johannes has a complex design with strong definition. His ability to understand will condition these changes.

It is important to remember that what is defined in an Individual design is permanent. The planetary connections are transitory and cyclical. What opens, closes. This is neither good nor bad. This is energy. We are designed to connect to the energy of the stars and we are also designed to connect with each other. The Composite Rave is not simply for understanding how we connect with the program. This is the base field. Perhaps the most important application of

the Composite is to see clearly the connections between people.

When you take the Body Graph of two individuals and you superimpose them over each other, where they connect is revealed. A Human Being has what is described mystically as an Auric Field, that is a field of energy which surrounds our bodies. This energy body stretches out around us about as far as your arms can stretch out. When you enter another Human Being's Auric Field, you connect with them based on your unique designs. How you connect and where you connect determines the nature of the relationship.

Imagine someone who has a strong Ajna Center. They have an ability to understand. The design is limited in this case in that there are no permanent connections to the Head center, inspiration. There are only potential connections. This individual can sit down at a café and someone will come and sit down with their back to them. They do not know each other but by the design of the café, they are sitting back to back in each other's Auric Field. Suddenly our Ajna center player has an inspiration while the other arrives at an understanding. While the inspired one sits and muses, the understanding leads the other to get up and leave. The connections are broken. The process ends. All that remains is the memory.

Imagine our example of Johannes. If there is a female in his life who connects his Solar Plexus Center, the basis of the relationship for Johannes will be emotional.

How we connect determines the quality and feel of our relationships. This is essential knowledge. A new mother is altered for many, many years by the close contact with the

child. The circuitry becomes one and the old individual is lost. To understand the design of the child is to prepare the Mother. A couple that sleeps in the same bed are literally one. To understand the connections is to find yourself in the union.

A feel of a connection can be misleading if not understood. If an individual has an unconnected Splenic center (cleansing) their physical defense system is vulnerable. At another level, their ability to cleanse vibrations, experiences, is limited. If this type of design connects with a defined Splenic center, the immediate result is that this person is going to make them feel better. It is possible in this situation that the feeling better is the only beneficial connection. Why we hold onto to somebody in our lives, why we persist in suffering is often misunderstood, illusions.

The understanding of these connections is the purpose of the Rave I Ching. The I Ching is an ancient work of wisdom. The Chinese saw the universe divided between a Yin and a Yang that in fusion become the Tao. The I Ching commonly understood in the West as an Oracle was originally the divisions of a Chinese Zodiac. Based on the 64, the binary as in computer mathematics and genetics, the I Ching examines the complete spectrum of Human experience. In this tradition each of the Hexagrams is subdivided to six groups called the Lines. Each line is a variation on the theme of the hexagram.

The Rave I Ching is a reinterpretation of the I Ching based on the Human Design System. The Rave I Ching is a reference work, like an encyclopedia. Beginning with the first Hexagram each field of energy is examined and explained in

relation to the system. Each line of a hexagram is a separate field of energy and can be located on the wheel. Each line measures 56'15'' of arc. When one knows the exact position of a planet one can place the planet in a traditional zodiacal sign, then a hexagram and finally the line.

The I Ching wheel is composed of opposing energies, variations on Yin and Yang themes. The same is true of a line. In the Rave I Ching the general meaning of the Hexagram/Gate is given followed by a detailed analysis of each line. These analyses show the polarity of each energy. The journey begins with understanding your own Rave. The calculations of the two Wheels provides you with exact positions and the corresponding Gate and line. By looking up the Gate in the Rave I Ching you can easily find the explanation for that energy. Important to remember is that there is a lot of information in an individual design. Start your understanding with the basic Body Graph design. This is the overview. Come to know the keynotes which describe the centers. (Inspiration, understanding, doing etc.) The basic body design shows you your definition but more important where you are receptive.

It helps to remember that the Body Graph is essentially divided into three parts. The Mental centers (Head, Ajna, Throat), the Physical centers (Heart, Spleen, Solar Plexus, and the two engines; the Sacral and the Center at the Base of the Spine), and the Coordinator, the center of our gravity, the Spiritual center, the G. Center.

In examining your own design, the mental not connected to the physical has no outlet. It is a common enough occurrence

in our lives to have ideas and not the energy to use them or energy and no idea what to do with it.

Once you have an understanding of the basic design then you can begin the exploration of the Hexagram Gates. First the Hexagrams themselves. They are archetypal definitions brought into focus by the lines. Their meaning is conditioned by the channel they open into and by what Gate and Center are at the other end. They are finally conditioned by the planet that activates them. Each planet by tradition and thousands of years of observation have specific meanings. Each planet's significance will condition the interpretation of the line.

In the same manner that one explores one's own design, the design of the Daily Rave and the design of others can be understood. The Rave Ephemeris of Body Graphs provides the Hexagram and line of all planets for every day. With the Rave I Ching these patterns can be interpreted and then applied to one's own chart. The same with any composite. The Rave I Ching is the basic reference.

The Human Design System is made up of many disciplines and it would be impossible to include in this work all of this knowledge. The Rave I Ching provides a condensed information pool. Thousands of books have been written about these sciences. The Rave I Ching is a guide to using a new system.

New is a much overused word in our world. Perhaps it would be better to refer to it as a different system. It is different. It came whole as a revelation in 1987 in January, and since then has been shared with people from all over the planet. It has proven to be remarkably accurate. This does

not mean that it is the truth. To this writer, it appears to be so, but more important are the conclusions that can be drawn from it.

In working with clients over the years, the Rave analysis consistently reveals that people do not love themselves. What they see in the mirror is never really satisfying. There is either something they wish to be or something they wished they hadn't done. There is expectation on one side and guilt on the other. The Human Design System shows that this is the movie, illusion, the maya.

We are a design system. We do not choose. Everything happens. Where is the blame? To love oneself is to recognize one's uniqueness. It is a proven fact that 'sameness' is a dead-end street. Uniqueness guarantees adaption and development. Let's return to the theme of the universe as the Child, the foetus. We can make the analogy that each life has the same relationship to the Child, the totality, that each gene has to an individual's genetic make-up. That the whole is always greater than the sum of its parts is relevant in both examples.

It means that each Human Being is special, literally and objectively, not subjectively. It means that each life is of great importance (no matter what our judgment), that all experiences, knowledge and conditions contribute essential material for the developing totality.

The keynote is acceptance. By acceptance, I do not mean resignation. Loving thyself is the first path to inner peace. If one is struggling to be equal, the reflection in the mirror will never be satisfying. There will always be something missing, something that could be better. By focusing

so intently on mythic standards, it is easy to be blind to one's own special beauty.

Acceptance begins with recognizing your own uniqueness. Its design is clearly visible. Acceptance is to lift the burden of judgment off your shoulders. There may be others who know a lot, but they do not know what you know. There may be others who have a lot, but they do not have what you have or feel what you feel or see what you see. Acceptance is recognizing that your life and its geometry are special and that they have a real purpose. No matter what your state, your life contributes your uniqueness to the whole.

The Human Design System through the Rave Charts can help you to identify and appreciate your own uniqueness and how it integrates to the whole.

The interpreting of the Rave is an act of Synthesis. The Hexagrams of the I Ching are the synthesizing medium. The I Ching is also referred to as the Book of Changes and change is the nature of the universe. The Human Design System is based on seeing change as the result of our cyclical connections with different types of energy. The wheel of the Rave is broken up into sixty-four archetypal energies. These are the Hexagrams of the I Ching.

The Rave I Ching is more than an interpretation of the Hexagrams and their six lines. It also connects this knowledge with the rest of the components of the system, so that the information can be put into proper perspective. As you can see in the example below, for each Hexagram, the Rave I Ching lists and keynotes the astrological sign and its quality, the Center and its related Biology, and the

Gate opened and its Channel. This is followed by a general thematic description of the Hexagram and then an analysis of each of its lines.

Peace

Sign: Sagittarius-Mutable. Philosophy Religion Idealism

Center: The Ajna Center. Knowing Intuition Understanding

Biology: The Anterior and Posterior Pituitary Glands

Gate: 11 Peace

Harmonic Gate: 56 The Wanderer

Channel: 11-56 Curiosity. The design of the searcher

A harmonic condition in the individual or society that permits assessment before renewed action.

The Lines

1 - Attunement. The serendipity of being in the right place at the right time. The Moon exalted. The nourishment derived from being with those who share the same goals and aspirations. Mars in detriment. The fear of anonymity.

(The words 'exalted' and 'detriment' are used throughout to express the duality of the energy of each line. It is not simply a matter of good or bad, positive or negative but an expression of the energy's range.)

For each Hexagram there is an illustration of the Hexagram's position on the wheel and in the Body Graph. The exact position of the Hexagram and each of its six lines is given in degrees, minutes and seconds of arc.

The I Ching is based on the Yin/Yang duality. The sixty-four Hexagrams are divided into two groups of thirty-two. From absolutely Yin (The Receptive 2) to the absolutely Yang (The Creative 1) the entire spectrum of energy is covered. Each line is also a duality. Every energy has a polarity. The form of the I Ching is to use images, examples, stories and ideas to express the potentials of these energies.

In describing these archetypal energies and their aspects, one is ultimately describing roles. Since these energies are the archetypes of Humanity, all the basic roles appear.

For easy reference, the Rave I Ching lists the Hexagrams in numerical order.

We now have the completed Rave of Johannes. Here we can begin our interpretive journey. The circuitry revealed in the Body Graph of Johannes does not change. That is an extremely important fact to digest. It means that life is not something that we change but rather that life changes us. To begin with, the Body Graph has two major aspects. There are centers which are permanently connected and therefore defined. There are also centers that are not permanently connected. There are certain channels that are not opened at all, from either end. There are many, many Gates that are not opened. This represents our potential of receptivity.

If we could gather all of the people in Johannes' life and asked them to describe him; what they will generally and in common describe is what is defined in his design. In all their interactions with him this definition is the most consistent trait.

In terms of the Human Design System, we are all aspects of a totality. Each with a unique design, yet at the same time, we are designed to integrate with the totality; with family and friends, with the neighbourhood, the region, the nation, the planet. What is defined in us is our foundation. What is not defined, what is receptive is how we connect to the world. It is what changes us. It is what confuses us. For example: in the Rave of Johannes his Ajna center (his understanding) is permanently connected to the Throat center

(his doing). The way in which Johannes translates what he understands into action is defined and this definition will be with him the rest of his life. On the other hand, the Solar Plexus center of Johannes is neither permanently connected, nor are any of the potential Gates opened. Johannes' emotional field is undefined. What he will experience emotionally in his life will constantly change depending on the movement of the planets and the people directly in his life. As with all energy, this is neither good, nor bad. Such sensitivity can result in a deep understanding of emotional range. It can also lead to great confusion about ones own emotional life.

Now that we have completed the basic introduction to the Human Design System, we can look in more detail at the mechanics of analysis. The foundation is the individual Rave. Once this has been calculated and interpreted, then you can begin to see a.) the effect that each new day has on your design, and b.) the effect of all relationships on your design, and c.) these effects either past, present or future.

In the introduction, we used the example of Johannes. Now that you are familiar with the basic information, the following pages will illustrate how an analysis is done.

Illustration 1, next page. The Body Graph of Johannes. This illustration contains all the information necessary to do an analysis. All the positions are given by hexagram and line.

The first step in analysis is the overview. In many ways it is similar to how we meet a stranger. The overview is conditioned by what is defined and what is not. It is the

Illustration 1

● Design

Personality ●

Johannes

Cancer Dog

3 ⁺	⊙	28 ⁺
50 ⁺	⊕	40 ⁺
58 ⁺	☾	2 ⁺
12 ⁺	☽	45 ⁺
11 ⁺	☺	26 ⁺
17 ⁺	♀	7 ⁺
23 ⁺	♀	40 ⁺
56 ⁺	♂	47 ⁺
32 ⁺	4	57 ⁺
53 ⁺	♁	56 ⁺
35 ⁺	♁	45 ⁺
18 ⁺	♁	18 ⁺
33 ⁺	♁	33 ⁺

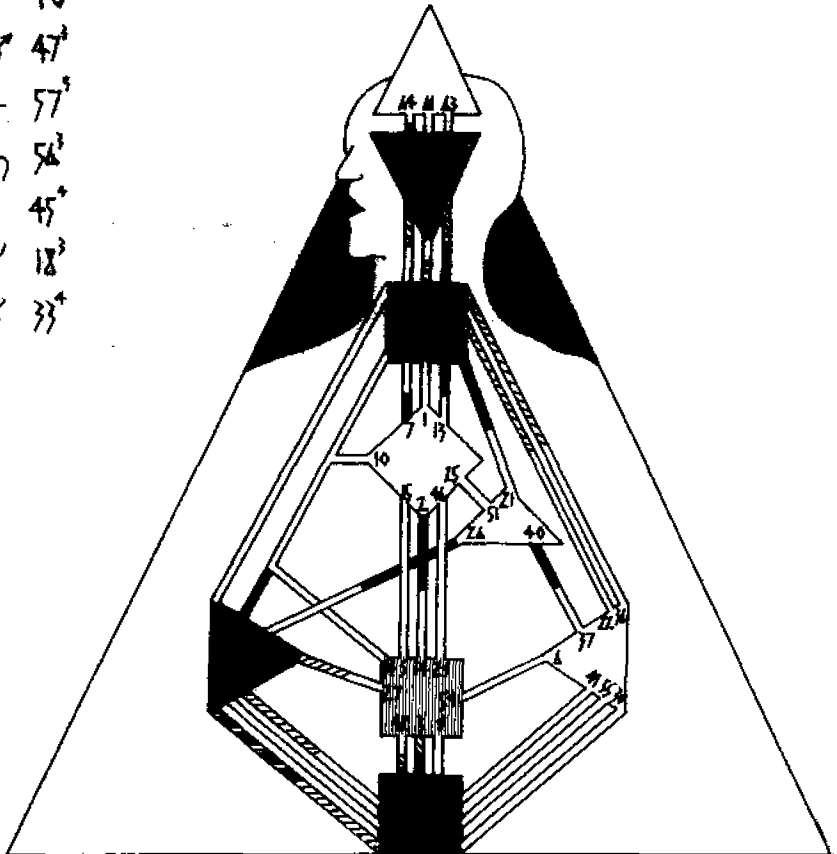

stranger's definition that we are most aware of, and so with the Body Graph. In looking at Johannes' Chart, it is the centers which are coloured that attract our attention. This is his definition. (Definition: when two centers are permanently connected by design from birth.) Definition means the continual transfer of energy between two centers. Johannes has definition between the Ajna (Understanding) and the Throat (Doing). In meeting him as a stranger, you would feel his intelligence. In this connection, understanding leads to doing, and doing to understanding. This is the channel of Curiosity, of the searcher.

Johannes has definition between the Splenic (Cleansing) and the Base of the Spine (Energy). A defined splenic center is a key to a healthy life. This is a stranger with whom you can be comfortable. It is easy for him to make you feel good. However, this is a channel of Judgment. Johannes is by definition never satisfied and therefore neither are those who he makes feel good. (This is not necessarily negative, we are always speaking of energy.) Not being satisfied is healthy for Johannes. It fires his mental curiosity as well.

Johannes' third definition is between the Sacral (Sexual) and the Base of the Spine (Energy). The Sacral and Spine are the two engines of the body, one general, the Spine, and the other specific sexual and reproductive. The connections between these centers divide the energy into three types, Cyclic, Pulse (like with Johannes), and Focused. By definition Johannes' energy will constantly fluctuate, and this definition is connected permanently to the other definition of Judgment.

In returning to illustration 1, we see clearly that Johannes has two areas of definition, the mental definition with its design of curiosity, and the powerful energy definition of the Sacral and Spine fuelling the cleansing center through the design of insatiability.

Based on this design, no matter what doing leads to understanding or what understanding leads to doing, Johannes will never feel satisfied. In looking first at definition by channel, we get the general information that a personality projects. The next step is to look at what is not defined, and again beginning with an overview. Once you have assessed the meaning of the definition, it is important to see, if there are more than two areas of definition (as in this case), whether they are connected to each other.

For Johannes' understanding and ability to do to manifest (stop being ideas and become actions), his mental centers would have to be connected to his energy centers. They are not. For example, without this connection, he cannot understand that he makes people feel good. He might notice it, but not understand it. Conversely, when his curiosity triumphs and he truly understands something, without this connection, he would remain unsatisfied and self-critical.

You will see that the most important people in Johannes' life will provide this bridge between these areas of definition. Before continuing with this analysis, let's look at Johannes' design through the channels, illustration 2. Here the body graph is broken up into five parts for easier focus, and a check list is provided for each gate that is open in the design and what that potential is. We will return to this illustration as a reference.

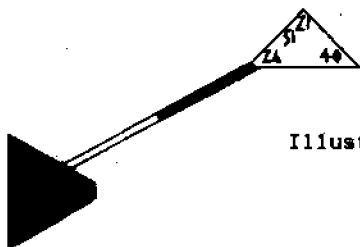
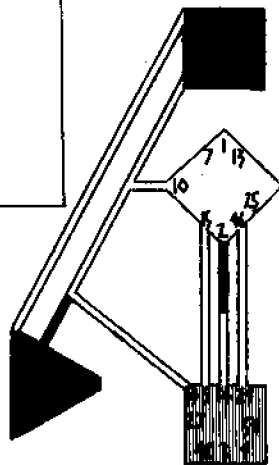
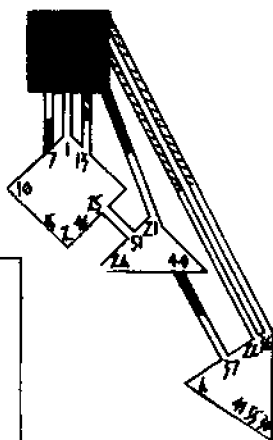
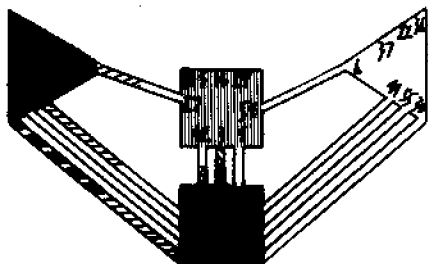

Illustration 2



Channel	Hexagrams	Keynote
<u>Abstraction</u>	64 - 47	A design of mental activity and clarity
<u>Awareness</u>	61 - 24	A design of a thinker
<u>Logic</u>	63 - 4	A design of mental ease mixed with doubt
<u>Acceptance</u>	17 - 62	A design of an organizational being
<u>Structuring</u>	43 - 23	A design of individuality
• <u>Curiosity</u>	11 - 56	<u>A design of a searcher</u>
<u>Awakening</u>	20 - 10	A design of commitment to higher principles
<u>The Alpha</u>	31 - 7	For 'good' or 'bad' a design of leadership
<u>Inspiration</u>	8 - 1	The creative role model
<u>The Prodigal</u>	33 - 13	The design of a witness
<u>The Wavelength</u>	16 - 48	A design of talent
<u>The Brain Wave</u>	20 - 57	A design of penetrating awareness
<u>Charisma</u>	20 - 34	A design where thoughts must become deeds
<u>Transitoriness</u>	35 - 36	A design of a 'Jack of all trades'
<u>Openness</u>	12 - 22	A design of a social being
<u>Exploration</u>	10 - 34	A design of following one's convictions
<u>Rhythm</u>	15 - 5	A design of being in the flow
<u>Beast</u>	2 - 14	A design of being the keeper of keys
<u>Discovery</u>	46 - 29	A design of succeeding where others fail
<u>Perfected Form</u>	10 - 57	A design for survival
<u>Initiation</u>	25 - 51	A design of needing to be first
<u>Community</u>	40 - 37	A design of being a part seeking a whole
<u>Surrender</u>	26 - 44	A design of a transmitter
<u>Money</u>	21 - 45	A design of a materialist
<u>Maturation</u>	42 - 53	A design of balanced development, cyclic
• <u>Mutation</u>	3 - 60	<u>Energy which fluctuates and initiates pulses</u>
<u>Concentration</u>	9 - 52	A design of determination, focused
<u>Mating</u>	59 - 5	A design focused on reproduction
<u>Power</u>	34 - 57	A design of an archetype
<u>Preservation</u>	27 - 50	A design of custodianship
<u>Transformation</u>	32 - 54	A design of being driven
<u>Struggle</u>	28 - 38	A design of stubbornness
• <u>Judgment</u>	18 - 58	<u>A design of insatiability</u>
<u>Synthesis</u>	49 - 19	A design of being sensitive
<u>Emoting</u>	55 - 39	A design of moodiness
<u>Recognition</u>	30 - 41	A design of focused energy



In looking at Johannes' body graph, you can see that the simplest bridge between his areas of definition is through the hexagram 20. This is the hexagram of Contemplation, and when it is connected to the hexagram 57, the result is the energy of penetrating awareness. This is when Johannes understands and is in harmony with his body. See illustration 3: the bridge changes the design. All bridges are temporary. If the bridge is made by a planet, the length of time the bridge exists depends on the speed of the planet's movements. (Pluto the longest, approximately three years, and the Moon the shortest and most frequent, approximately half a day, once a month. The Sun for example enters the hexagram 20 the beginning of Gemini, in the late spring each year for about five days. All exact timings can be found in an ephemeris).

It is important to remember that when you are analysing an individual body graph, it is being done in isolation. We are not at any times in our lives separate. This bridge from the 20th gate which is so important to Johannes, has been and will be available to him all his life, through the planets and others. There are also many other potential bridges.

We have looked at Johannes' definition and what it means, when areas of definition are not permanently connected. Just as the coloured centers attract our attention, the opposite is also true. The undefined centers are also essential in taking in the overview. An undefined center is just that, not connected, without its own intrinsic nature. For example, the three gates of Johannes' Head center are not open by design. This is the center of Inspiration. Johannes' inspiration must come from the outside. People will

R A V E

Channel and Definition

Analysis Graph

Illustration 3

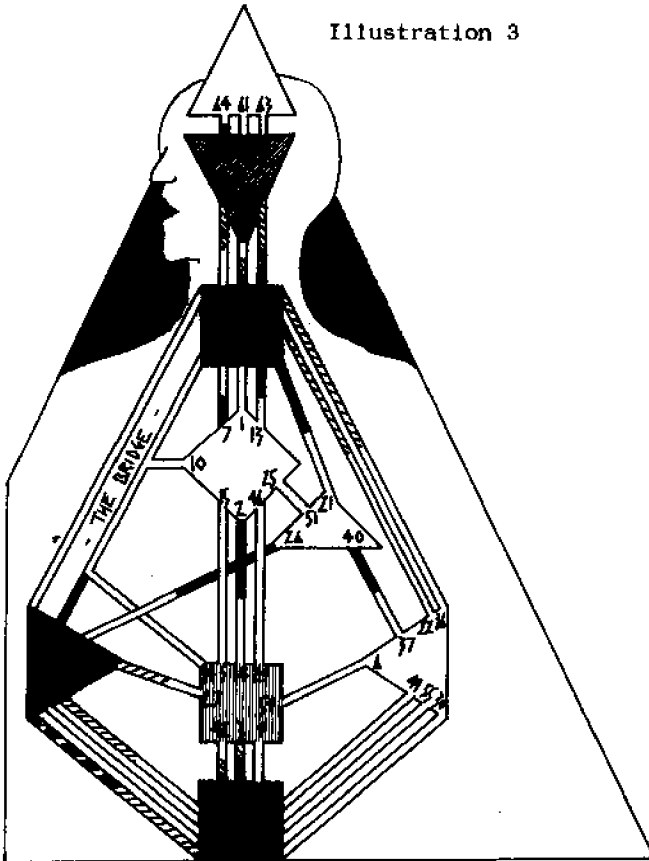

naturally seek him out for understanding but not for inspiration. The same applies to Johannes' Solar Plexus center, which was discussed in the introduction. An undefined center is always vulnerable. It is where our life changes. Let's look at two visual examples of what a difference a day makes. The body graphs of illustration 4 and 5 are composites of the program for the day and Johannes.

We will return to these composites for reference later. Now we will just look at them simply from our overview. In the composite of June 5, one more center, the Spiritual center, is connected as a result of the general program. There is not only one, but two channels connected between the throat and spiritual centers. If you now refer to illustration 2 and its check list, you will see that Johannes had the potential for leadership, the 7th gate, and with Mars opening the 31st gate of Influence, Johannes' program for the day will include energetic leadership (for good or bad). The second channel is opened entirely by the planets. This channel is the design of the Role model. It is not in Johannes' design at all. Therefore, he will experience what it is like to be a role model and will effect others in that way. This is a temporary phenomenon, but it is very useful to know when it is coming. As a business man, it would be an excellent time to stand out. It is a time when Johannes' understanding is much more penetrating.

Despite the impact of these two channel openings, Johannes remains unsatisfied. The overview still shows the separation between these two areas of definition.

Another effect of this day is the additional completion of connections between already defined centers. Between the

Illustration 4

Wednesday, June 5, 1991

Johannes

- ☉ 35'
- ⊕ 5'
- ☾ 63
- ♁ 61'
- ♂ 62'
- ♀ 8'
- ♂ 58'
- ♂ 31'
- ♁ 33'
- ♁ 41^f R
- ♁ 38^f R
- ♁ 54^f R
- ♁ 1^f R

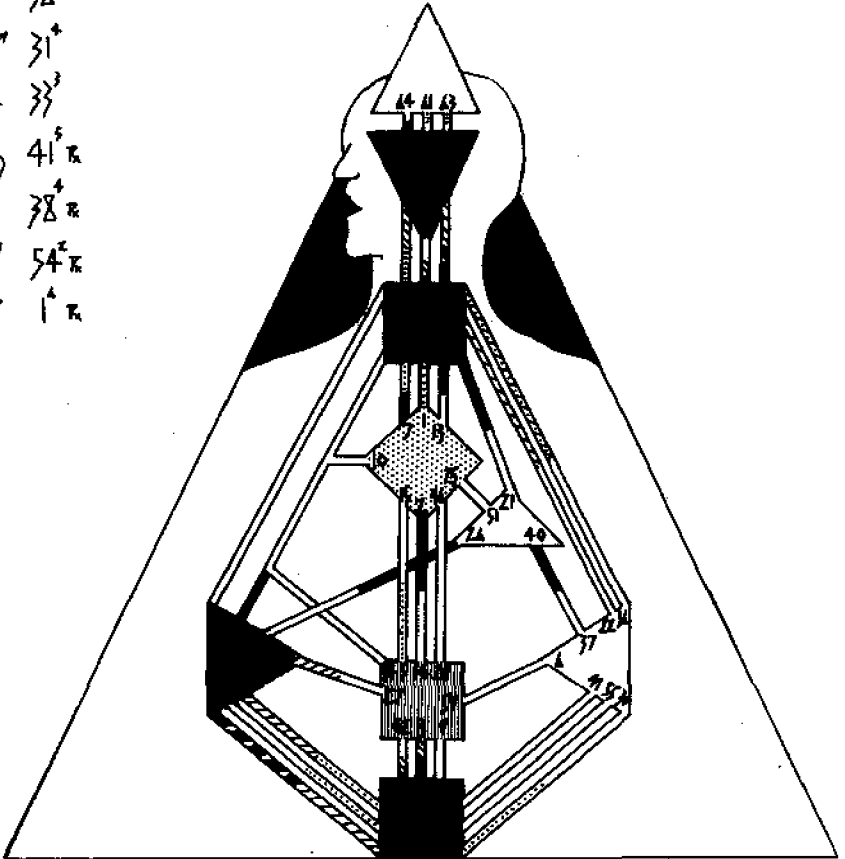

Ajna and Throat centers, Johannes has the 17th gate open, the harmonic gate 62 is being opened by the South Node. (The Nodes stay approximately three months in a hexagram/gate.) This channel is the design of the organizational being. Detail work and following plans. This is a beneficial balance to Johannes' curiosity. As you can see, the program for this day has added to Johannes' mental potential. The organized curiosity that can act as a role model through its leadership. Still, remember that no matter what the potential may be, it still requires energy to manifest. Johannes still has no bridge, and more difficult, an additional connection has been made between his Splenic and Spine center. This is the energy of transformation opened up by Neptune in the 54th gate. (Neptune is in a gate for several years.) The design is of being driven. This is ambition. Coupled with his insatiability, and that neither has an outlet, Johannes is without harmony. He seems to know, and others respect him, but he is unsatisfied. Others see him as a role model, while his ambition ignores his own accomplishments.

This can seem to be a very difficult picture, until you remember that every person in his life, from mailman, co-worker, lover, clerk makes these essential bridges all the time, and of course the program changes. Look at the next day, illustration 5.

Before looking at the major difference, the connecting of the Solar Plexus center (the emotions), and the appearance of the bridge, let's first briefly compare the two. For both days the relationship between understanding and doing remains the same, balanced between organization and

Illustration 5

Thursday, June 6, 1991

Johannes

- ☉ 35⁺
- ⊕ 5⁺
- ☾ 36
- ☿ 41⁺
- ♊ 42⁺
- ♋ 20⁺
- ♌ 56⁺
- ♍ 31⁺
- ♎ 33⁺
- ♏ 41⁺ R
- ♐ 38⁺ R
- ♑ 54⁺ R
- ♒ 1⁺ R

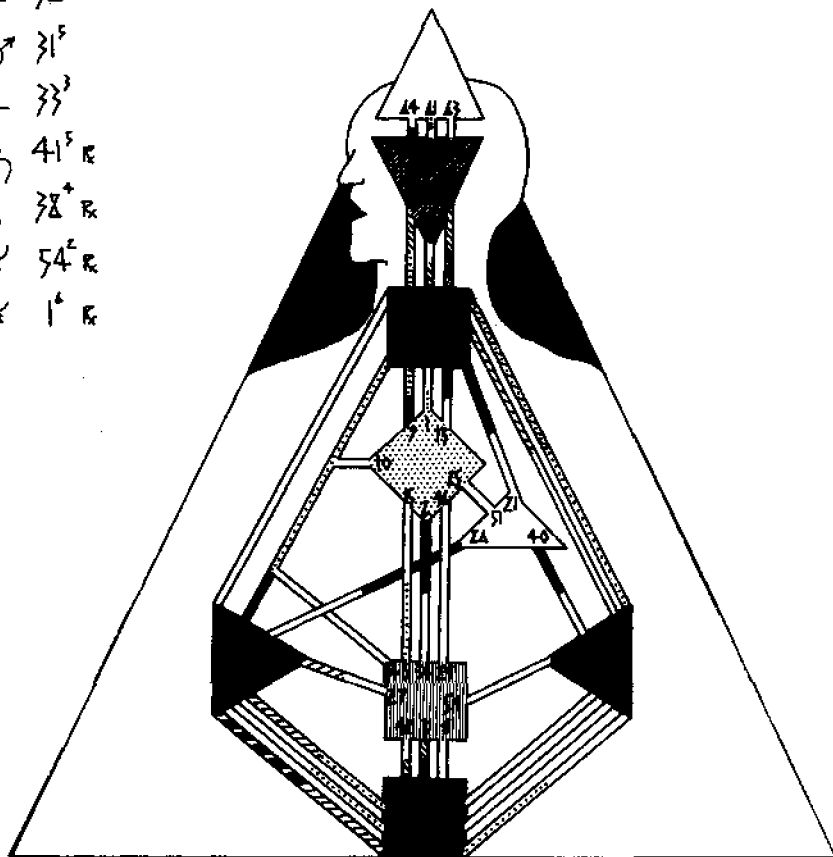

curiosity. The definition between the throat and spiritual center remains, but it's been diminished. Mercury which opened the 8th gate on June 5th completing the channel of the role model, moves into the 20th hexagram/gate on the 6th of June. Johannes is no longer a role model, but he now has the awareness to understand himself much better. We will return to this theme when we leave the overview and take the microscope.

It is not a surprise, given our inherent duality, that the 'Gods' always give with one hand and take away with the other. Johannes with Mercury as the muse has the real experience of knowing what he is about, only to have it clouded by the definition of his emotional field. Johannes' Solar Plexus center has not a single potential opening from the seven center gates. Johannes has no emotional foundation. All emotions challenge him. This connection is made by the Moon and is therefore of short duration (approximately half a day).

It is here that the value of the Human Design System expresses itself. Johannes like most beings assumes that his life is his and that he is responsible for it. When it goes wrong he looks for blame or fault or mistakes, when it goes right he is congratulatory.

On the 5th of June, he felt great, he still had his nagging insatiability, but he was used to that. When he woke up on the 6th he had a different program. He was now aware of his body, his senses were more acute. While he showers, he begins to question whether he is really ready for a more difficult position. He sees his own accomplishments in a better light. By the time he arrives at the office, the Moon

has entered the 36th gate, the Darkening of the Light. Whatever the trigger will be, a phone call, a letter, a look, or a thought, the emotional burst will come.

Whatever the result, when Johannes goes to sleep the night of the 6th, the Moon will have left the gate. The emotional field will return to normal, except that Johannes has the memory of how he felt, and in many cases what problems it generated within himself or others. Since he has no control over it and therefore cannot understand it, he will rationalize. It is what we do. He will try to understand it and he will end up blaming himself and/or others.

There is no blame and there is no fault. Life happens. If Johannes could see this overview, he would experience his life differently. He cannot change it but he can experience it differently. He does not have to suffer unnecessarily and that makes a difference in any life.

This is the first step in analysis, the overview. It is useful to use this technique when looking briefly at other body graphs. It tells you a great deal quickly. And in using the Rave Ephemeris of Body Graphs, which give you the design for each day of the year, you can use this technique to scan days and weeks ahead to take note of key days in relation to your design. It is better to be prepared. To know what is coming really helps. This is not like a 'crystal ball', this is just defining energy patterns, and these patterns are scientifically calculable. Through this system you see what the energy is going to be and how it effects your personal design.

When you are looking at your own design, you want to go beyond the overview. Here is where the general design

becomes specific. The most important tool is at least a keynote understanding of the meanings of the planets. Such a reference is in this introduction, but a solid understanding of the planets, though not necessary, is of great benefit. The planets are the conditioners of the gates.

When we began with this overview, we concentrated on the obvious defined and undefined areas. In a detail study start at the top and look at everything. You have the overview in mind, it is your frame of reference.

We discussed earlier that Johannes has no definition between his Head and Ajna centers. By design, understanding without

inspiration, but this is far too general. In illustration 6, we see

Illustration 6



a detail of this area. In the Ajna beneath the 47th gate is the symbol for Mars ♂.

(In the reference to the meaning of the Planets given in the introduction, Mars is described as energy, power, assertion, desire, and aggression. This is traditionally a strong energy.)

In looking at the detail, we see that the only potential connection

between these two centers is conditioned by Mars' energy. Remember in this stage of analysis, we are not considering the effects of the program or others, just the detailed design.

The Rave I Ching that follows explains the meaning of the hexagrams/gates in detail. We will refer to it as the detail reference guide. It is a dictionary of meanings.

Johannes has his Personality Mars in the 47th hexagram/gate, Oppression. (The hexagrams are placed in numerical order for easy reference.) The Harmonic gate in the Head center is the 64th hexagram/gate, Before Completion. Together they complete the channel of Abstraction with its design of mental activity and clarity. If he possessed the whole channel, the meaning would be clear, and Mars would add its energy, but that is not his design. The abstract process can be a burden. It is an incessant inner voice, the mental activity ranges from the profound to the banal. (Again, remember not to judge, the talkative, even babbling inner voice will eventually produce gems of awareness.) The next step is to recognize the difference between which side is open. Johannes' understanding waits for inspiration, not inspiration waiting for understanding.

Without inspiration Johannes' mental activity is focused on what he already understands, on his memory, on the past. This can be both enlightening and punishing. What in this case would be an advantage to an analyst, would be a less comfortable design in his depressive patient.

In the opposite case where inspiration awaits understanding, it can be very disturbing, to have so much cross your mind and to have it be of little relevance.

The energy is always able to flow both ways. This is important in understanding partially opened channels. As in this case. The hexagram 47 is Oppression, such mental activity is a weight, and Mars can make it a burden. The mental activity has a powerful fuel. It is fortunate for Johannes that he can transform his understanding into doing. As a busy person, his busy mind is in rhythm. In others who do not have a

defined Ajna, it would be much less harmonic and to a lesser or greater degree, a challenge. It is so important to stress that there is no blame. You cannot stop your inner voice. It can happen, but that is not up to you. Most of the suffering in the world is the ego confronted by helplessness, when it has been conditioned to know otherwise.

To complete our detail analysis of this relationship between inspiration and understanding, we can now finally look at the conditioning line. Each hexagram has six lines. (This information for Johannes is given in illustration 1.) In the Reve I Chart under the hexagram 47 is given the line definitions. Johannes' Mars lies within the third line. It is called Self-oppression.

Line definitions are broken up into three parts. The general keynote description and the two polarities here called excited and detriment. These are old terms and may be confusing in that they suggest good and bad. This is not so. When a planet is associated with a line specifically, that aspect of the duality is heightened. The two sides of the lines are always present to greater or lesser degrees. We are dualities.

You can see by reading this line, that given what we already know about Johannes, this will add greatly to his sense of dissatisfaction and add to his judgmental nature. A self-oppression so highly energized that it may prove irreversible and destructive. The opposite is also present in the design, but overshadowed by Mars. It is those moments when the self-oppression is recognized. Again you are reminded, that this is Johannes in isolation, which does not exist. Any program or person that completes this connection

will lift most of the weight of this design off his shoulders. We really do need, must have, are designed to have others in our lives.

When doing your own analysis, follow this procedure. Begin with the overview and its concentration on definition and the channels. Then work through each gate, first through the planet and then the hexagram and line. In this way your own design will be revealed in detail. Like learning any system, at first it takes time, but in beginning with yourself you already have a guide. As you recognize what you accept, you will also recognize what you know about yourself that you do not like, and discover what you had never considered about yourself. All of which prepares you to understanding the effect of others on you and to be better equipped to meet the challenges of your life by being aware of what is and is going to happen to you.

Below is one of the meanings of love. This is what Johannes normally looks like for the last eighteen years. This is a composite of Johannes and his wife. Who you work with, who you play with makes a difference. Who you sleep with makes a big difference.

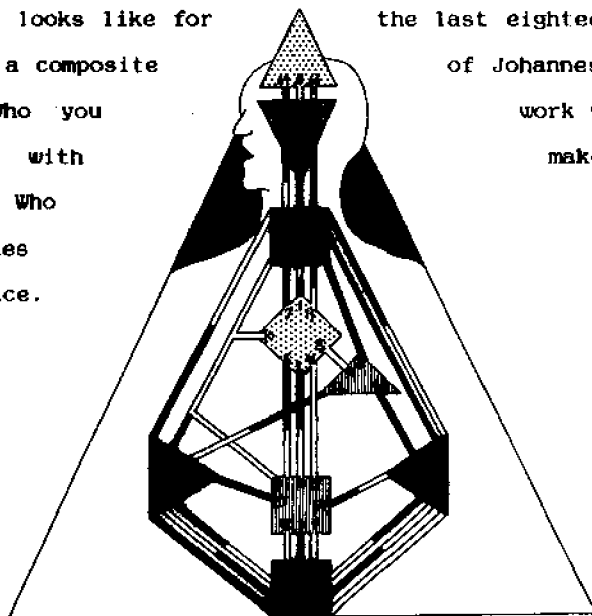

On the following page is a detailed illustration, 7, showing the design of Renate and how it connects with Johannes. Partnership comparisons are the most interesting and useful applications of the Human Design System. It is how we connect with others that determines how we experience them.

When looking at this composite of this couple you can begin to see, what they mean when they say that people are meant for each other. Let's take an overview look at Renate. There is a single definition. It is between the Throat and the Heart (Ego Zeal Passion) centers. This is the design of a very open being. Which such little definition she needs stable relationships.

The channel manifests the design of a materialist. This is the Money line. Possessive as a child, a saver and collector as an adult. Wealth comes to these people, but it also is the focus of their attention. To have and to own is very important.

In our look at Johannes, we focused on the relationship between the Head and Ajna centers. Renate has the opposite gate, 64 Before Completion opened. Alone, she had mental activity with no relevance, and he, mental activity without clarity, together, in each others aura (it can stretch across a house) this system is complete and defined. Johannes gets his inspiration, and Renate relevance. It is a wonderful gift. They are not responsible, and yet it's what happens when they are together.

Together he can be a leader and he doesn't need a planet to do it for him. Most important for Johannes, together he has

an emotional base. Together they connect and define the Heart to the Solar Plexus center. Johannes' emotional field is experienced through the channel of Community and its design of a part seeking to be one with the whole. Through this connection they are more than friends, there is a kinship.

Through Renate opening the gate of Grace 22 in the Solar Plexus center connecting to Johannes' 12th gate, the channel of Openness is open. This is the design of the social being. You can see clearly that Johannes who by design is so vulnerable emotionally, has a partner who connects him to the most stable and healthy fields. Through the channels of Community and Openness, Johannes has a balanced emotional life.

This brings us to the end of our discussion. I wish you well in your journey. The Human Design System is a wonderful gift. This is knowledge that can really help you in your life. It will remind you that you do not choose, that you are unique, and it will make a difference because you can be prepared.

R A V E

Channel and Definition

Analysis Graph

Illustration 7

Composite Renate

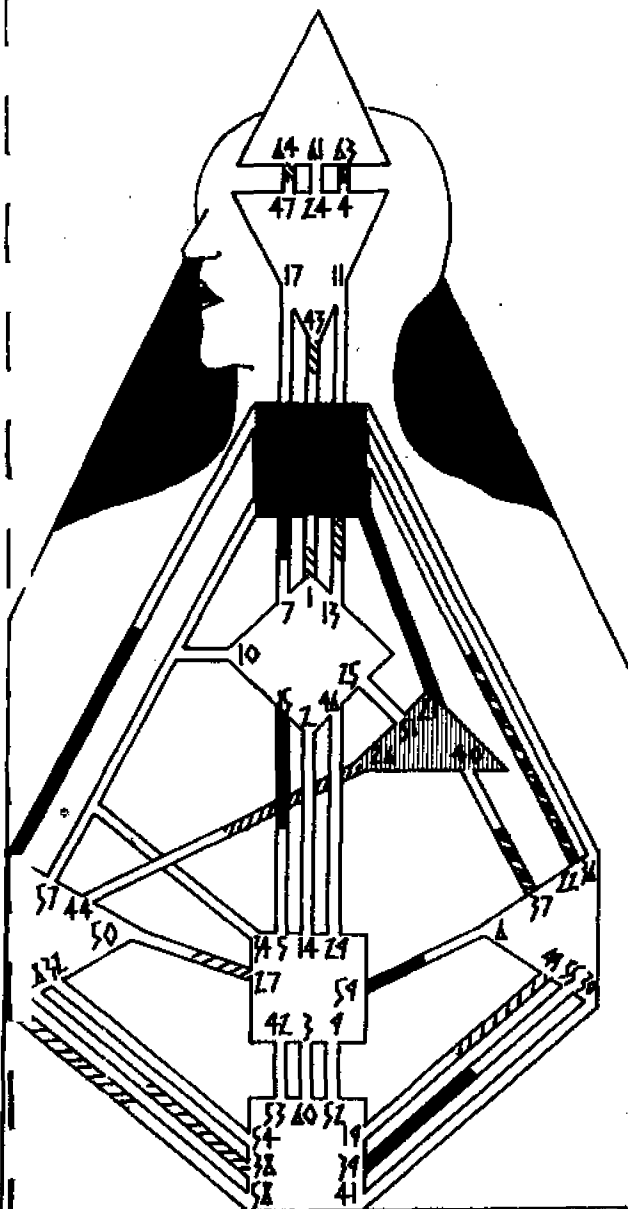

Channel	Hexagrams
● <u>Abstraction</u>	64 - 47
Awareness	61 - 24
Logic	63 - 4
Acceptance	17 - 62
● <u>Structuring</u>	43 - 23
Curiosity	11 - 56
Awakening	20 - 10
● <u>The Alpha</u>	31 - 7
Inspiration	8 - 1
The Prodigal	33 - 13
The Wavelength	16 - 48
The Brain Wave	20 - 57
Charisma	20 - 34
Transitoriness	35 - 36
● <u>Openness</u>	12 - 22
Exploration	10 - 34
Rhythm	15 - 5
Beat	2 - 14
Discovery	46 - 29
Perfected Form	10 - 57
Initiation	25 - 51
● <u>Community</u>	40 - 37
Surrender	26 - 44
● <u>Money</u>	21 - 45
Maturation	42 - 53
Mutation	3 - 60
Concentration	9 - 52
Mating	59 - 6
Power	34 - 57
● <u>Preservation</u>	27 - 50
Transformation	32 - 54
Struggle	28 - 38
Judgment	18 - 58
Synthesis	49 - 19
Emoting	55 - 39
Recognition	30 - 41

Johannes ●

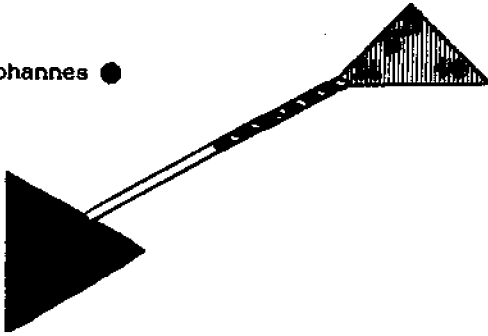

Keynote

- A design of mental activity and clarity
- A design of a thinker
- A design of mental ease mixed with doubt

- A design of an organizational being
- A design of individuality
- A design of a searcher

- A design of commitment to higher principles
- For 'good' or 'bad' a design of leadership
- The creative role model
- The design of a witness

- A design of talent
- A design of penetrating awareness
- A design where thoughts must become deeds

- A design of a 'Jack of all trades'
- A design of a social being

- A design of following one's convictions
- A design of being in the flow
- A design of being the keeper of keys
- A design of succeeding where others fail

- A design for survival

- A design of needing to be first

- A design of being a part seeking a whole
- A design of a transmitter
- A design of a materialist

- A design of balanced development, cyclic
- Energy which fluctuates and initiates, pulse
- A design of determination, focused

- A design focused on reproduction

- A design of an archetype
- A design of custodianship

- A design of being driven
- A design of stubbornness
- A design of insatiability

- A design of being sensitive
- A design of woodiness
- A design of focused energy

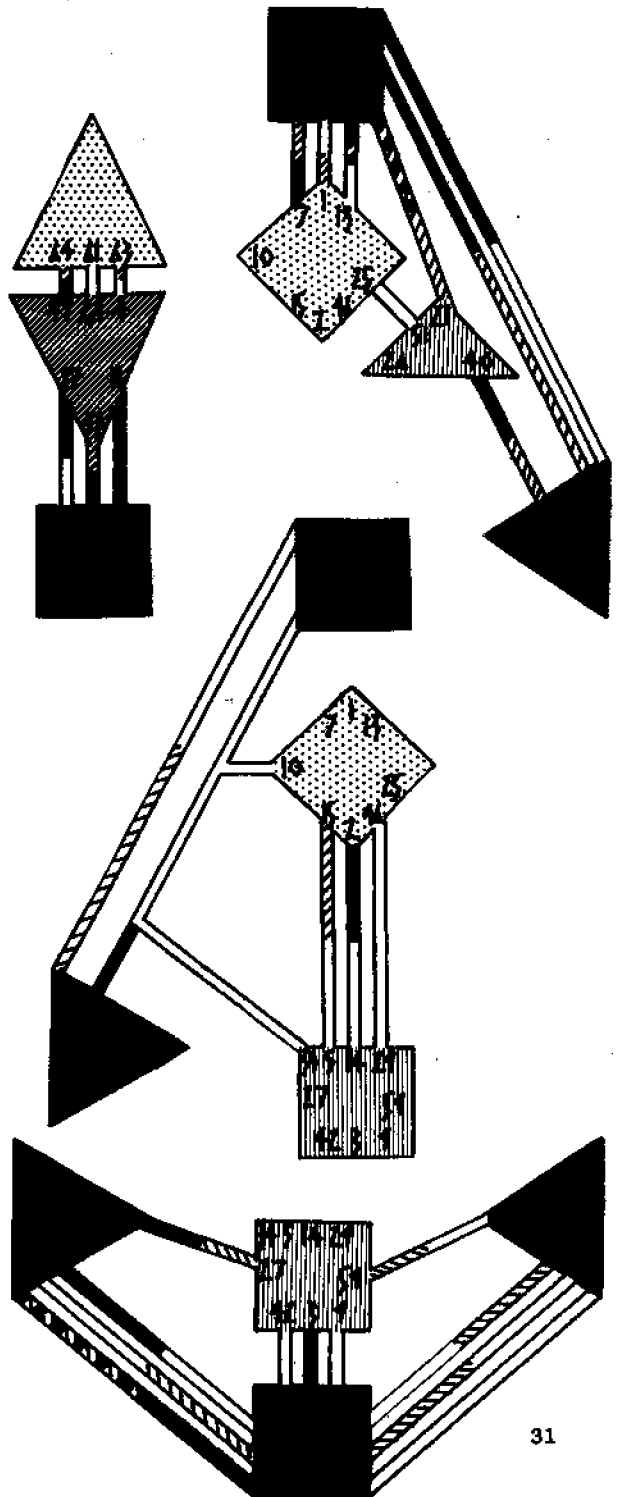

R A V E

Channel and Definition

Analysis Graph

Illustration 7

Composite Renate

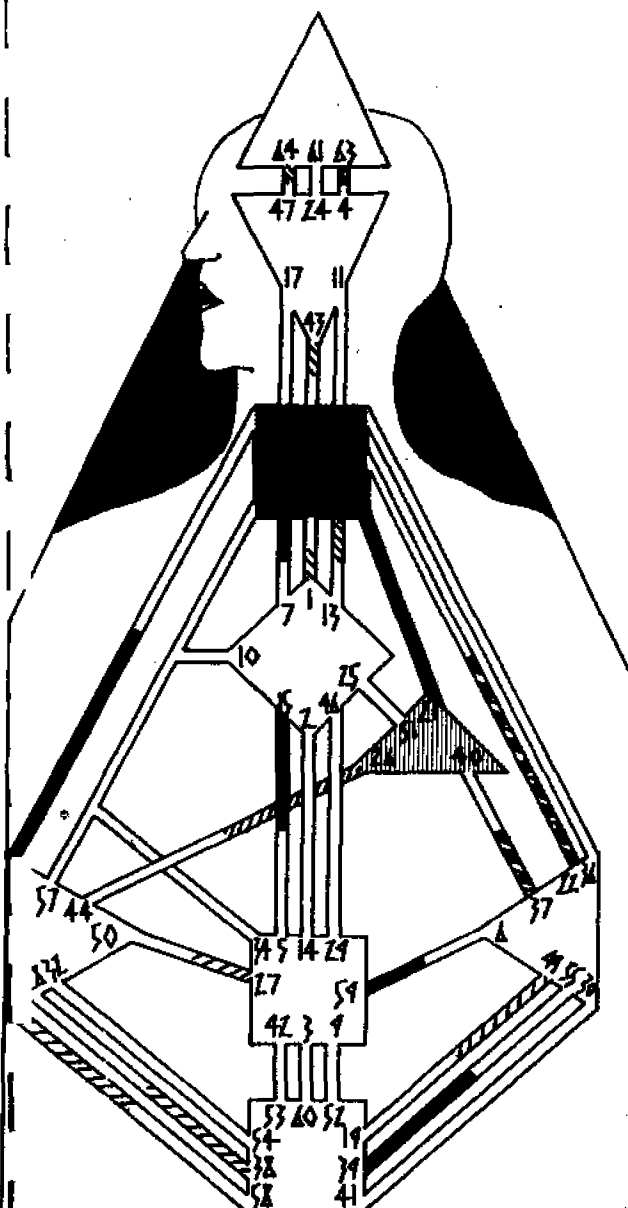

Channel	Hexagrams
● <u>Abstraction</u>	64 - 47
Awareness	61 - 24
Logic	63 - 4
Acceptance	17 - 62
● <u>Structuring</u>	43 - 23
Curiosity	11 - 56
Awakening	20 - 10
● <u>The Alpha</u>	31 - 7
Inspiration	8 - 1
The Prodigal	33 - 13
The Wavelength	16 - 48
The Brain Wave	20 - 57
Charisma	20 - 34
Transitoriness	35 - 36
● <u>Openness</u>	12 - 22
Exploration	10 - 34
Rhythm	15 - 5
Beat	2 - 14
Discovery	46 - 29
Perfected Form	10 - 57
Initiation	25 - 51
● <u>Community</u>	40 - 37
Surrender	26 - 44
● <u>Money</u>	21 - 45
Maturation	42 - 53
Mutation	3 - 60
Concentration	9 - 52
Mating	59 - 6
Power	34 - 57
● <u>Preservation</u>	27 - 50
Transformation	32 - 54
Struggle	28 - 38
Judgment	18 - 58
Synthesis	49 - 19
Emoting	55 - 39
Recognition	30 - 41

Johannes ●

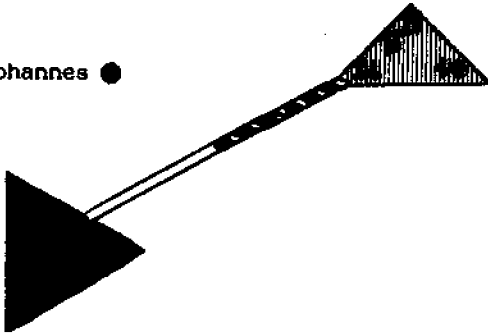

Keynote

- A design of mental activity and clarity
- A design of a thinker
- A design of mental ease mixed with doubt

- A design of an organizational being
- A design of individuality
- A design of a searcher

- A design of commitment to higher principles
- For 'good' or 'bad' a design of leadership
- The creative role model
- The design of a witness

- A design of talent
- A design of penetrating awareness
- A design where thoughts must become deeds

- A design of a 'Jack of all trades'
- A design of a social being

- A design of following one's convictions
- A design of being in the flow
- A design of being the keeper of keys
- A design of succeeding where others fail

- A design for survival

- A design of needing to be first

- A design of being a part seeking a whole
- A design of a transmitter
- A design of a materialist

- A design of balanced development, cyclic
- Energy which fluctuates and initiates, pulse
- A design of determination, focused

- A design focused on reproduction

- A design of an archetype
- A design of custodianship

- A design of being driven
- A design of stubbornness
- A design of insatiability

- A design of being sensitive
- A design of woodiness
- A design of focused energy

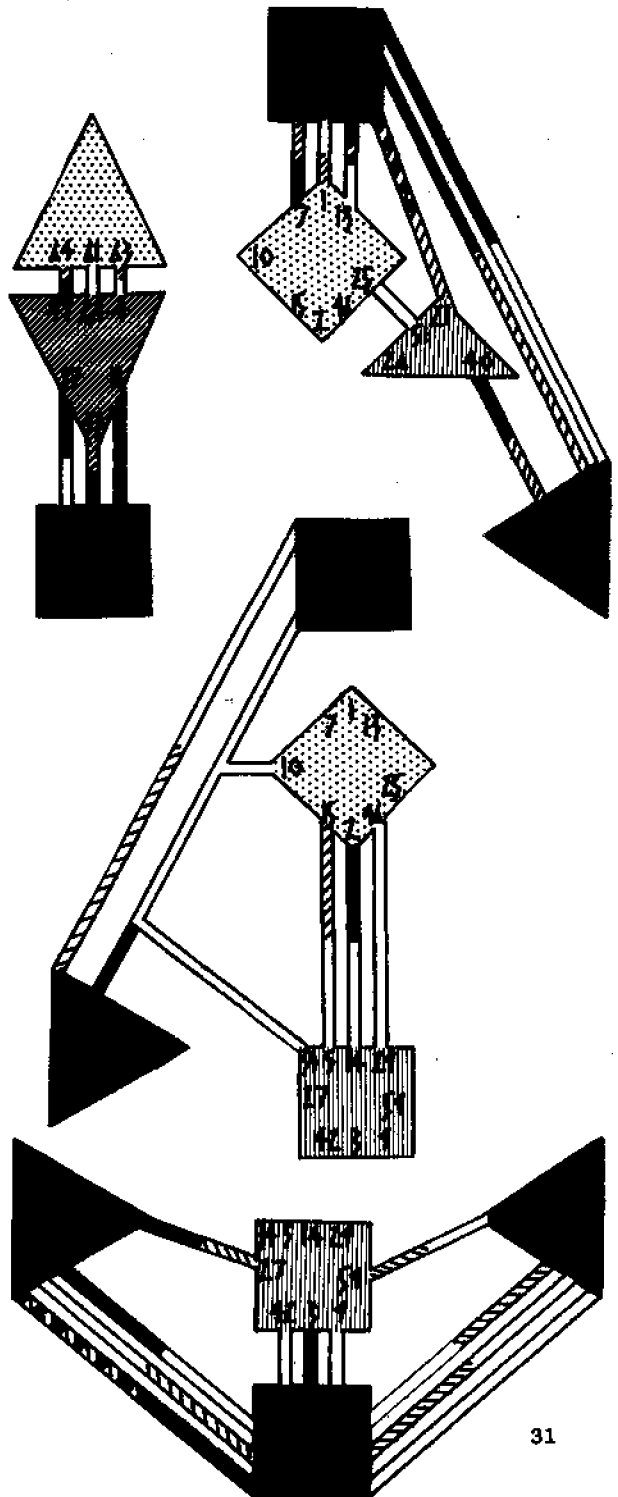

L \ U	☰	☷	☱	☲	☵	☴	☶	☳
☰	1	34	5	26	11	9	14	43
☷	25	51	3	27	24	42	21	17
☱	6	40	29	4	7	59	64	47
☲	33	62	39	52	15	53	56	31
☵	12	16	8	23	2	20	35	45
☴	49	32	48	18	46	57	50	28
☶	13	55	63	22	36	37	30	49
☳	10	54	60	41	19	61	38	58

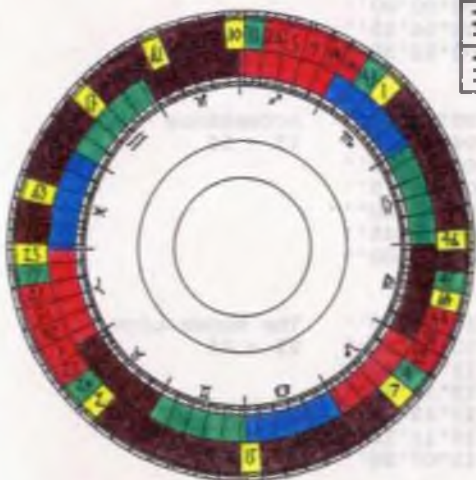

The 64 Hexagrams

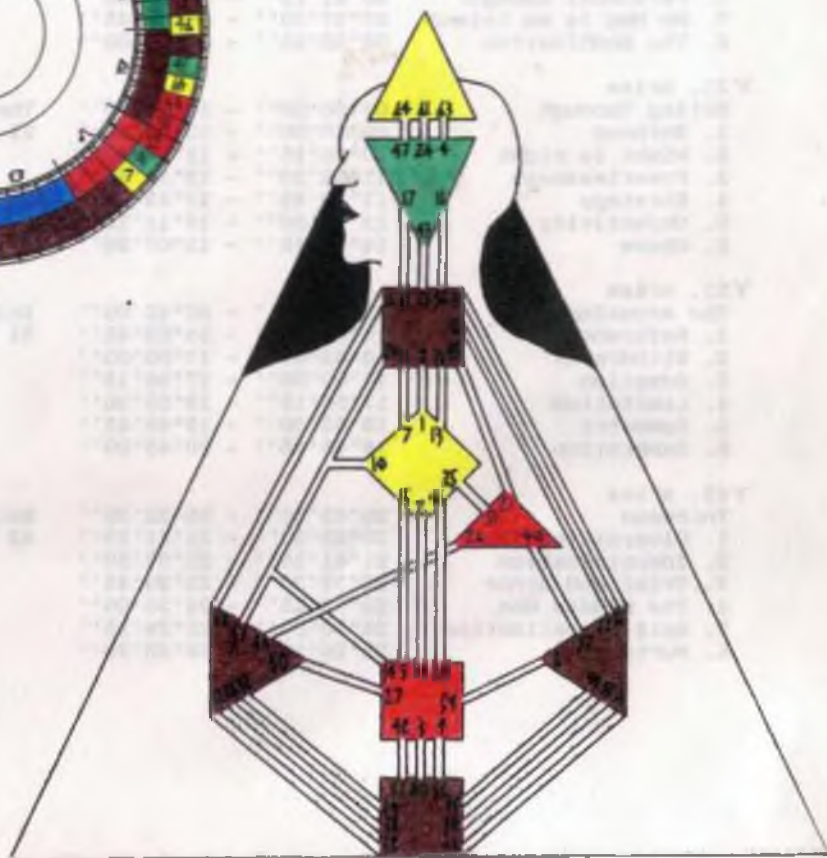

The Hexagrams and the Astrological Signs

Gate/Sign Hexagram/Lines	Position	Channel
Y25. Aries		
Innocence	28°15'00" - 03°52'30"	Initiation
1. Selflessness	28°15'00" - 29°11'15"	25 - 51
2. The Existentialist	29°11'15" - 00°07'30"	
3. Sensibility	00°07'30" - 01°03'45"	
4. Survival	01°03'45" - 02°00'00"	
5. Recuperation	02°00'00" - 02°56'15"	
6. Ignorance	02°56'15" - 03°52'30"	
Y17. Aries		
Following	03°52'30" - 09°30'00"	Acceptance
1. Openness	03°52'30" - 04°48'45"	17 - 62
2. Discrimination	04°48'45" - 05°45'00"	
3. Understanding	05°45'00" - 06°41'15"	
4. Personnel Manager	06°41'15" - 07°37'30"	
5. No Man is an Island	07°37'30" - 08°33'45"	
6. The Bodhisattva	08°33'45" - 09°30'00"	
Y21. Aries		
Biting Through	09°30'00" - 15°07'30"	The Money Line
1. Warning	09°30'00" - 10°26'15"	21 - 45
2. Might is right	10°26'15" - 11°22'30"	
3. Powerlessness	11°22'30" - 12°18'45"	
4. Strategy	12°18'45" - 13°15'00"	
5. Objectivity	13°15'00" - 14°11'15"	
6. Chaos	14°11'15" - 15°07'30"	
Y51. Aries		
The Arousing	15°07'30" - 20°45'00"	Initiation
1. Reference	15°07'30" - 16°03'45"	51 - 25
2. Withdrawal	16°03'45" - 17°00'00"	
3. Adaption	17°00'00" - 17°56'15"	
4. Limitation	17°56'15" - 18°52'30"	
5. Symmetry	18°52'30" - 19°48'45"	
6. Separation	19°48'45" - 20°45'00"	
Y42. Aries		
Increase	20°45'00" - 26°22'30"	Maturation
1. Diversification	20°45'00" - 21°41'15"	42 - 53
2. Identification	21°41'15" - 22°37'30"	
3. Trial and Error	22°37'30" - 23°33'45"	
4. The Middle Man	23°33'45" - 24°30'00"	
5. Self-actualization	24°30'00" - 25°26'15"	
6. Nurturing	25°26'15" - 26°22'30"	

Gate/Sign Hexagram/Lines	Position	Channel
Y 3. Aries/Taurus Difficulty at the Beginning	26°22'39" - 02°00'00"	Mutation 2 - 60
1. Synthesis	26°22'30" - 27°18'45"	
2. Immaturity	27°18'45" - 28°15'00"	
3. Survival	28°15'00" - 29°11'15"	
4. Charisma	29°11'15" - 00°07'30"	
5. Victimization	00°07'30" - 01°03'45"	
6. Surrender	01°03'45" - 02°00'00"	
8 27. Taurus Nourishment	02°00'00" - 07°37'30"	Preservation 27 - 50
1. Selfishness	02°00'00" - 02°56'15"	
2. Self-sufficiency	02°56'15" - 03°52'30"	
3. Greed	03°52'30" - 04°48'45"	
4. Generosity	04°48'45" - 05°45'00"	
5. The Executor	05°45'00" - 06°41'15"	
6. Wariness	06°41'15" - 07°37'30"	
8 24. Taurus Returning	07°37'30" - 13°15'00"	Awareness 24 - 61
1. The Sin of Omission	7°37'30" - 08°33'45"	
2. Recognition	08°33'45" - 09°30'00"	
3. The Addict	09°30'00" - 10°26'15"	
4. The Hermit	10°26'15" - 11°22'30"	
5. Confession	11°22'30" - 12°18'45"	
6. The Gift Horse	12°18'45" - 13°15'00"	
8 2. Taurus The Receptive	13°15'00" - 18°52'30"	The Beat 2 - 14
1. Intuition	13°15'00" - 14°11'15"	
2. Genius	14°11'15" - 15°07'30"	
3. Patience	15°07'30" - 16°03'45"	
4. Secretiveness	16°03'45" - 17°00'00"	
5. Intelligent application	17°00'00" - 17°56'15"	
6. Fixation	17°56'15" - 18°52'30"	
8 23. Taurus Splitting Apart	18°52'30" - 24°30'00"	Structuring 23 - 43
1. Proselytization	18°52'30" - 19°48'45"	
2. Self-defence	19°48'45" - 20°45'00"	
3. Individuality	20°45'00" - 21°41'15"	
4. Fragmentation	21°41'15" - 22°37'30"	
5. Assimilation	22°37'30" - 23°33'45"	
6. Fusion	23°33'45" - 24°30'00"	

Gate/Sign Hexagram/Lines	Position	Channel
8. Taurus/Gemini Holding Together	24°30'00'' - 00°07'30''	Inspiration
1. Honesty	24°30'00'' - 25°26'15''	8 - 1
2. Service	25°26'15'' - 26°22'30''	
3. The Phoney	26°22'30'' - 27°18'45''	
4. Respect	27°18'45'' - 28°15'00''	
5. Dharma	28°15'00'' - 29°11'15''	
6. Communion	29°11'15'' - 00°07'30''	
20. Gemini Contemplation	00°07'30'' - 05°45'00''	Awakening
1. Superficiality	00°07'30'' - 01°03'45''	20 - 10
2. The Dogmatist	01°03'45'' - 02°00'00''	Charisma
3. Self-awareness	02°00'00'' - 02°56'15''	20 - 34
4. Application	02°56'15'' - 03°52'30''	The Brain Wave
5. Realism	03°52'30'' - 04°48'45''	20 - 57
6. Wisdom	04°48'45'' - 05°45'00''	
16. Gemini Enthusiasm	05°45'00'' - 11°22'30''	The Wave Length
1. Delusion	05°45'00'' - 06°41'15''	16 - 48°
2. The Cynic	06°41'15'' - 07°37'30''	
3. Independence	07°37'30'' - 08°33'45''	
4. The Leader	08°33'45'' - 09°30'00''	
5. The Grinch	09°30'00'' - 10°26'15''	
6. Gullibility	10°26'15'' - 11°22'30''	
35. Gemini Progress	11°22'30'' - 17°00'00''	Transitoriness
1. Humility	11°22'30'' - 12°18'45''	35 - 36
2. Creative block	12°18'45'' - 13°15'00''	
3. Collaboration	13°15'00'' - 14°11'15''	
4. Hunger	14°11'15'' - 15°07'30''	
5. Altruism	15°07'30'' - 16°03'45''	
6. Rectification	16°03'45'' - 17°00'00''	
45. Gemini Gathering Together	17°00'00'' - 22°27'30''	The Money Line
1. Canvassing	17°00'00'' - 17°56'15''	45 - 21
2. Consensus	17°56'15'' - 18°52'30''	
3. Exclusion	18°52'30'' - 19°48'45''	
4. Direction	19°48'45'' - 20°45'00''	
5. Leadership	20°45'00'' - 21°41'15''	
6. Reconsideration	21°41'15'' - 22°37'30''	

Gate/Sign Hexagram/Lines	Position	Channel
II 12. Gemini Standstill	22°37'30'' - 28°15'00''	Openness
1. The Monk	22°37'30'' - 23°33'45''	12 - 22
2. Purification	23°33'45'' - 24°30'00''	
3. Confession	24°30'00'' - 25°26'15''	
4. The Prophet	25°26'15'' - 26°22'30''	
5. The Pragmatist	26°22'30'' - 27°18'45''	
6. Metamorphosis	27°18'45'' - 28°15'00''	
II ☲ 15. Gemini/Cancer Modesty	28°15'00'' - 03°52'30''	Rhythm
1. Duty	28°15'00'' - 29°11'15''	15 - 5
2. Influence	29°11'15'' - 00°07'30''	
3. Ego inflation	00°07'30'' - 01°03'45''	
4. The Wallflower	01°03'45'' - 02°00'00''	
5. Sensitivity	02°00'00'' - 02°56'15''	
6. Self-defense	02°56'15'' - 03°52'30''	
☳ 52. Cancer Keeping Still	03°52'30'' - 09°30'00''	Concentration
1. Think before you speak	03°52'30'' - 04°48'45''	52 - 9
2. Concern	04°48'45'' - 05°45'00''	
3. Controls	05°45'00'' - 06°41'15''	
4. Self-discipline	06°41'15'' - 07°37'30''	
5. Explanation	07°37'30'' - 08°33'45''	
6. Peacefulness	08°33'45'' - 09°30'00''	
☳ 39. Cancer Obstruction	09°30'00'' - 15°07'30''	Emoting
1. Disengagement	09°30'00'' - 10°26'15''	39 - 55
2. Confrontation	10°26'15'' - 11°22'30''	
3. Responsibility	11°22'30'' - 12°18'45''	
4. Temperance	12°18'45'' - 13°15'00''	
5. Single-mindedness	13°15'00'' - 14°11'15''	
6. The Troubleshooter	14°11'15'' - 15°07'30''	
☳ 53. Cancer Development	15°07'30'' - 20°45'00''	Maturation
1. Accumulation	15°07'30'' - 16°03'45''	53 - 42
2. Momentum	16°03'45'' - 17°00'00''	
3. Practicality	17°00'00'' - 17°56'15''	
4. Assuredness	17°56'15'' - 18°52'30''	
5. Assertion	18°52'30'' - 19°48'45''	
6. Phasing	19°48'45'' - 20°45'00''	

Gate/Sign Hexagram/Lines	Position	Channel
62. Cancer Preponderance of the Small	20°45'00'' - 26°22'30''	Acceptance 62 - 17
1. Routine	20°45'00'' - 21°41'15''	
2. Restraint	21°41'15'' - 22°37'30''	
3. Discovery	22°37'30'' - 23°33'45''	
4. Asceticism	23°33'45'' - 24°30'00''	
5. Metamorphosis	24°30'00'' - 25°26'15''	
6. Self-discipline	25°26'15'' - 26°22'30''	
56. Cancer/Leo The Wanderer	26°22'30'' - 02°00'00''	Curiosity 56 - 11
1. Quality	26°22'30'' - 27°18'45''	
2. Linkage	27°18'45'' - 28°15'00''	
3. Alienation	28°15'00'' - 29°11'15''	
4. Expediency	29°11'15'' - 00°07'30''	
5. Attracting attention	00°07'30'' - 01°03'45''	
6. Caution	01°03'45'' - 02°00'00''	
31. Leo Influence	02°00'00'' - 07°37'30''	The Alpha 31 - 7
1. Manifestation	02°00'00'' - 02°56'15''	
2. Arrogance	02°56'15'' - 03°52'30''	
3. Selectivity	03°52'30'' - 04°48'45''	
4. Intent	04°48'45'' - 05°45'00''	
5. Self-righteousness	05°45'00'' - 06°41'15''	
6. Application	06°41'15'' - 07°37'30''	
33. Leo Retreat	07°37'30'' - 13°15'00''	The Prodigal 33 - 13
1. Avoidance	07°37'30'' - 08°33'45''	
2. Surrender	08°33'45'' - 09°30'00''	
3. Spirit	09°30'00'' - 10°26'15''	
4. Dignity	10°26'15'' - 11°22'30''	
5. Timing	11°22'30'' - 12°18'45''	
6. Disassociation	12°18'45'' - 13°15'00''	
47. Leo The Army	13°15'00'' - 18°52'30''	The Alpha 7 - 31
1. Authoritarian	13°15'00'' - 14°11'15''	
2. The Democrat	14°11'15'' - 15°07'30''	
3. The Anarchist	15°07'30'' - 16°03'45''	
4. The Abdicator	16°03'45'' - 17°00'00''	
5. The General	17°00'00'' - 17°56'15''	
6. The Administrator	17°56'15'' - 18°52'30''	

Gate/Sign Hexagram/Lines	Position	Channel
♈ 4. Leo		
Youthful Folly	18°52'30'' - 24°30'00''	Logic
1. Pleasure	18°52'30'' - 19°48'45''	4 - 63
2. Acceptance	19°48'45'' - 20°45'00''	
3. Irresponsibility	20°45'00'' - 21°41'15''	
4. The Liar	21°41'15'' - 22°37'30''	
5. Seduction	22°37'30'' - 23°33'45''	
6. Excess	23°33'45'' - 24°30'00''	
♍ 29. Leo/Virgo		
The Abyssal	24°30'00'' - 00°07'30''	Discovery
1. The Draftee	24°30'00'' - 25°26'15''	29 - 46
2. Assessment	25°26'15'' - 26°22'30''	
3. Evaluation	26°22'30'' - 27°18'45''	
4. Directness	27°18'45'' - 28°15'00''	
5. Overreach	28°15'00'' - 29°11'15''	
6. Confusion	29°11'15'' - 00°07'30''	
♍ 59. Virgo		
Dispersion	00°07'30'' - 05°45'00''	Mating
1. The preemptive strike	00°07'30'' - 01°03'45''	59 - 6
2. Shyness	01°03'45'' - 02°00'00''	
3. Openness	02°00'00'' - 02°56'15''	
4. Brotherhood/ Sisterhood	02°56'15'' - 03°52'30''	
5. The Femme Fatale or Casanova	03°52'30'' - 04°48'45''	
6. The One Night Stand	04°48'45'' - 05°45'00''	
♍ 40. Virgo		
Deliverance	05°45'00'' - 11°22'30''	Community
1. Recuperation	05°45'00'' - 06°41'15''	40 - 37
2. Resoluteness	06°41'15'' - 07°37'30''	
3. Humility	07°37'30'' - 08°33'45''	
4. Organization	08°33'45'' - 09°30'00''	
5. Rigidity	09°30'00'' - 10°26'15''	
6. Decapitation	10°26'15'' - 11°22'30''	
♍ 64. Virgo		
Before Completion	11°22'30'' - 17°00'00''	Abstraction
1. Conditions	11°22'30'' - 12°18'45''	64 - 47
2. Qualification	12°18'45'' - 13°15'00''	
3. Over-extension	13°15'00'' - 14°11'15''	
4. Conviction	14°11'15'' - 15°07'30''	
5. Promise	15°07'30'' - 16°03'45''	
6. Victory	16°03'45'' - 17°00'00''	

Gate/Sign Hexagram/Lines	Position	Channel
♍ 47. Virgo Oppression	17°00'00" - 22°37'30"	Abstraction 47 - 64
1. Taking stock	17°00'00" - 17°56'15"	
2. Ambition	17°56'15" - 18°52'30"	
3. Self-oppression	18°52'30" - 19°48'45"	
4. Repression	19°48'45" - 20°45'00"	
5. The Saint	20°45'00" - 21°41'15"	
6. Futility	21°41'15" - 22°37'30"	
♍ 6. Virgo Conflict	22°37'30" - 28°15'00"	Mating 6 - 59
1. Retreat	22°37'30" - 23°33'45"	
2. The Guerrilla	23°33'45" - 24°30'00"	
3. Allegiance	24°30'00" - 25°26'15"	
4. Triumph	25°26'15" - 26°22'30"	
5. Arbitration	26°22'30" - 27°18'45"	
6. The Peacemaker	27°18'45" - 28°15'00"	
♍ ♎ 46. Virgo/Libra Pushing Upward	28°15'00" - 03°52'30"	Discovery 46 - 29
1. Being discovered	28°15'00" - 29°11'15"	
2. The Prima Donna	29°11'15" - 00°07'30"	
3. Projection	00°07'30" - 01°03'45"	
4. Impact	01°03'45" - 02°00'00"	
5. Pacing	02°00'00" - 02°56'15"	
6. Integrity	02°56'15" - 03°52'30"	
♎ 18. Libra Work on What Has Been Spoilt	03°52'30" - 09°30'00"	Judgment 18 - 58
1. Conservatism	03°52'30" - 04°48'45"	
2. Terminal disease	04°48'45" - 05°45'00"	
3. The Zealot	05°45'00" - 06°41'15"	
4. The Incompetent	06°41'15" - 07°37'30"	
5. Therapy	07°37'30" - 08°33'45"	
6. Buddhahood	08°33'45" - 09°30'00"	
♎ 48. Libra The Well	09°30'00" - 15°07'30"	The Wave Length 48 - 16
1. Insignificance	09°30'00" - 10°26'15"	
2. Degeneracy	10°26'15" - 11°22'30"	
3. Incommunicado	11°22'30" - 12°18'45"	
4. Restructuring	12°18'45" - 13°15'00"	
5. Action	13°15'00" - 14°11'15"	
6. Self-fulfillment	14°11'15" - 15°07'30"	

Gate/Sign Hexagram/Lines	Position	Channel
♎ 57. Libra		
The Gentle	15°07'30" - 20°45'00"	The Brain Wave
1. Confusion	15°07'30" - 16°03'45"	57 - 20
2. Cleansing	16°03'45" - 17°00'00"	Perfected Form
3. Acuteness	17°00'00" - 17°56'15"	57 - 10
4. The Director	17°56'15" - 18°52'30"	Power
5. Progression	18°52'30" - 19°48'45"	57 - 34
6. Utilization	19°48'45" - 20°45'00"	
♎ 32. Libra		
Duration	20°45'00" - 26°22'30"	Transformation
1. Conservation	20°45'00" - 21°41'15"	32 - 54
2. Restraint	21°41'15" - 22°37'30"	
3. Lack of continuity	22°37'30" - 23°33'45"	
4. Right is might	23°33'45" - 24°30'00"	
5. Flexibility	24°30'00" - 25°26'15"	
6. Tranquility	25°26'15" - 26°22'30"	
♎♏ 50. Libra/Scorpio		
The Cauldron	26°22'30" - 02°00'00"	Preservation
1. The Immigrant	26°22'30" - 27°18'45"	50 - 27
2. Determination	27°18'45" - 28°15'00"	
3. Adaptability	28°15'00" - 29°11'15"	
4. Corruption	29°11'15" - 00°07'30"	
5. Consistency	00°07'30" - 01°03'45"	
6. Leadership	01°03'45" - 02°00'00"	
♏ 28. Scorpio		
Preponderance of the Great	02°00'00" - 07°37'30"	Struggle
1. Preparation	02°00'00" - 02°56'15"	28 - 38
2. Shaking hands with the Devil	02°56'15" - 03°52'30"	
3. Adventurism	03°52'30" - 04°48'45"	
4. Holding on	04°48'45" - 05°45'00"	
5. Treachery	05°45'00" - 06°41'15"	
6. Blaze of glory	06°41'15" - 07°37'30"	
♏ 44. Scorpio		
Coming to Meet	07°37'30" - 13°15'00"	Surrender
1. Conditions	07°37'30" - 08°33'45"	44 - 26
2. Management	08°33'45" - 09°30'00"	
3. Interference	09°30'00" - 10°26'15"	
4. Honesty	10°26'15" - 11°22'30"	
5. Manipulation	11°22'30" - 12°18'45"	
6. Aloofness	12°18'45" - 13°15'00"	

Gate/Sign Hexagram/Lines	Position	Channel
♏ 1. Scorpio The Creative	13°15'00" - 18°52'30"	Inspiration
1. Creation	13°15'00" - 14°11'15"	1 - 8
2. Love is Light	14°11'15" - 15°07'30"	
3. Energy	15°07'30" - 16°03'45"	
4. Aloneness	16°03'45" - 17°00'00"	
5. Attraction	17°00'00" - 17°56'15"	
6. Objectivity	17°56'15" - 18°52'30"	
♏ 43. Scorpio Breakthrough	18°52'30" - 24°30'00"	Structuring
1. Patience	18°52'30" - 19°48'45"	43 - 23
2. Dedication	19°48'45" - 20°45'00"	
3. Expediency	20°45'00" - 21°41'15"	
4. The one-track mind	21°41'15" - 22°37'30"	
5. Progression	22°37'30" - 23°33'45"	
6. Breakthrough	23°33'45" - 24°30'00"	
♏ / ♐ 14. Scorpio/Sagittarius Possession in Great Measure	24°30'00" - 00°07'30"	The Beat
1. Money isn't everything	24°30'00" - 25°26'15"	14 - 2
2. Management	25°26'15" - 26°22'30"	
3. Service	26°22'30" - 27°18'45"	
4. Security	27°18'45" - 28°15'00"	
5. Arrogance	28°15'00" - 29°11'15"	
6. Humility	29°11'15" - 00°07'30"	
♐ 34. Sagittarius The Power of the Great	00°07'30" - 05°45'00"	Charisma
1. The Bully	00°07'30" - 01°03'45"	34 - 20
2. Momentum	01°03'45" - 02°00'00"	Exploration
3. Machismo	02°00'00" - 02°56'15"	34 - 10
4. Triumph	02°56'15" - 03°52'30"	Power
5. Annihilation	03°52'30" - 04°48'45"	34 - 57
6. Common sense	04°48'45" - 05°45'00"	
♐ 9. Sagittarius The Taming Power of the Small	05°45'00" - 11°22'30"	Concentration
1. Sensibility	05°45'00" - 06°41'15"	9 - 52
2. Misery loves company	06°41'15" - 07°37'30"	
3. The straw that breaks the camel's back	07°37'30" - 08°33'45"	
4. Dedication	08°33'45" - 09°30'00"	
5. Faith	09°30'00" - 10°26'15"	
6. Gratitude	10°26'15" - 11°22'30"	

Gate/Sign Hexagram/Lines	Position	Channel
♈ 5. Sagittarius		
Waiting	11°22'30'' - 17°00'00''	Rhythm
1. Perseverance	11°22'30'' - 12°18'45''	5 - 15
2. Inner Peace	12°18'45'' - 13°15'00''	
3. Compulsiveness	13°15'00'' - 14°11'15''	
4. The Hunter	14°11'15'' - 15°07'30''	
5. Joy	15°07'30'' - 16°03'45''	
6. Yielding	16°03'45'' - 17°00'00''	
♈ 26. Sagittarius		
The Taming Power of the Great	17°00'00'' - 22°37'30''	Surrender
1. A Bird in the hand	17°00'00'' - 17°56'15''	26 - 44
2. The lessons of history	17°56'15'' - 18°52'30''	
3. Influence	18°52'30'' - 19°48'45''	
4. Censorship	19°48'45'' - 20°45'00''	
5. Adaptability	20°45'00'' - 21°41'15''	
6. Authority	21°41'15'' - 22°37'30''	
♈ 11. Sagittarius		
Peace	22°37'30'' - 28°15'00''	Curiosity
1. Attunement	22°37'30'' - 23°33'45''	11 - 56
2. Rigour	23°33'45'' - 24°30'00''	
3. The Realist	24°30'00'' - 25°26'15''	
4. The Teacher	25°26'15'' - 26°22'30''	
5. The Philanthropist	26°22'30'' - 27°18'45''	
6. Adaptability	27°18'45'' - 28°15'00''	
♈ 10. Sagittarius/Capricorn		
Treading	28°15'00'' - 03°52'30''	Awakening
1. Modesty	28°15'00'' - 29°11'15''	10 - 20
2. The Hermit	29°11'15'' - 00°07'30''	Exploration
3. The Martyr	00°07'30'' - 01°03'45''	10 - 34
4. The Opportunist	01°03'45'' - 02°00'00''	Perfected Form
5. The Heretic	02°00'00'' - 02°56'15''	10 - 57
6. The Role Model	02°56'15'' - 03°52'30''	
♈ 58. Capricorn		
The Joyous	03°52'30'' - 09°30'00''	Judgment
1. Love of life	03°52'30'' - 04°48'45''	58 - 18
2. Perversion	04°48'45'' - 05°45'00''	
3. Electricity	05°45'00'' - 06°41'15''	
4. Focusing	06°41'15'' - 07°37'30''	
5. Defense	07°37'30'' - 08°33'45''	
6. Carried away	08°33'45'' - 09°30'00''	

Gate/Sign Hexagram/Lines	Position	Channel
♃ 38. Capricorn Opposition	09°30'00" - 15°07'30"	Struggle
1. Qualification	09°30'00" - 10°26'15"	38 - 28
2. Politeness	10°26'15" - 11°22'30"	
3. Alliance	11°22'30" - 12°18'45"	
4. Investigation	12°18'45" - 13°15'00"	
5. Alienation	13°15'00" - 14°11'15"	
6. Misunderstanding	14°11'15" - 15°07'30"	
♃ 54. Capricorn The Marrying Maiden	15°07'30" - 20°45'00"	Transformation
1. Influence	15°07'30" - 16°03'45"	54 - 32
2. Discretion	16°03'45" - 17°00'00"	
3. Covert interaction	17°00'00" - 17°56'15"	
4. Enlightenment/ Endarkenment	17°56'15" - 18°52'30"	
5. Magnanimity	18°52'30" - 19°48'45"	
6. Selectivity	19°48'45" - 20°45'00"	
♃ 61. Capricorn Inner Truth	20°45'00" - 26°22'30"	Awareness
1. Occult knowledge	20°45'00" - 21°41'15"	61 - 24
2. Natural brilliance	21°41'15" - 22°37'30"	
3. Interdependence	22°37'30" - 23°33'45"	
4. Research	23°33'45" - 24°30'00"	
5. Influence	24°30'00" - 25°26'15"	
6. Appeal	25°26'15" - 26°22'30"	
♃ 60. Capricorn/Aquarius Limitation	26°22'30" - 02°00'00"	Mutation
1. Acceptance	26°22'30" - 27°18'45"	60 - 3
2. Decisiveness	27°18'45" - 28°15'00"	
3. Conservatism	28°15'00" - 29°11'15"	
4. Resourcefulness	29°11'15" - 00°07'30"	
5. Leadership	00°07'30" - 01°03'45"	
6. Rigidity	01°03'45" - 02°00'00"	
♃ 41. Aquarius Decrease	02°00'00" - 07°37'30"	Recognition
1. Reasonableness	02°00'00" - 02°56'15"	41 - 30
2. Caution	02°56'15" - 03°52'30"	
3. Efficiency	03°52'30" - 04°48'45"	
4. Correction	04°48'45" - 05°45'00"	
5. Authorization	05°45'00" - 06°41'15"	
6. Contagion	06°41'15" - 07°37'30"	

Gate/Sign Hexagram/Lines	Position	Channel
♊ 19. Aquarius		
Approach	07°37'30" - 13°15'00"	Synthesis
1. Interdependence	07°37'30" - 08°33'45"	19 - 49
2. Service	08°33'45" - 09°30'00"	
3. Dedication	09°30'00" - 10°26'15"	
4. The Team Player	10°26'15" - 11°22'30"	
5. Sacrifice	11°22'30" - 12°18'45"	
6. The Recluse	12°18'45" - 13°15'00"	
♊ 13. Aquarius		
The Fellowship of Man	13°15'00" - 18°52'30"	The Prodigal
1. Empathy	13°15'00" - 14°11'15"	13 - 33
2. Bigotry	14°11'15" - 15°07'30"	
3. Pessimism	15°07'30" - 16°03'45"	
4. Fatigue	16°03'45" - 17°00'00"	
5. The Saviour	17°00'00" - 17°56'15"	
6. The Optimist	17°56'15" - 18°52'30"	
♊ 49. Aquarius		
Revolution	18°52'30" - 24°30'00"	Synthesis
1. The Law of Necessity	18°52'30" - 19°48'45"	49 - 19
2. The last resort	19°48'45" - 20°45'00"	
3. Popular discontent	20°45'00" - 21°41'15"	
4. Platform	21°41'15" - 22°37'30"	
5. Organization	22°37'30" - 23°33'45"	
6. Attraction	23°33'45" - 24°30'00"	
♊ * 30. Aquarius/Pisces		
Clinging Fire	24°30'00" - 00°07'30"	Recognition
1. Composure	24°30'00" - 25°26'15"	30 - 41
2. Pragmatism	25°26'15" - 26°22'30"	
3. Resignation	26°22'30" - 27°18'45"	
4. Burn out	27°18'45" - 28°15'00"	
5. Irony	28°15'00" - 29°11'15"	
6. Enforcement	29°11'15" - 00°07'30"	
* 55. Pisces		
Abundance	00°07'30" - 5°45'00"	Emoting
1. Co-operation	00°07'30" - 01°03'45"	55 - 39
2. Distrust	01°03'45" - 02°00'00"	
3. Innocence	02°00'00" - 02°56'15"	
4. Assimilation	02°56'15" - 03°52'30"	
5. Growth	03°52'30" - 04°48'45"	
6. Selfishness	04°48'45" - 05°45'00"	

Gate/Sign Hexagram/Linee	Position	Channel
* 37. Pisces		
The Family	05°45'00'' - 11°22'30''	Community
1. The Mother/Father	05°45'00'' - 06°41'15''	37 - 40
2. Responsibility	06°41'15'' - 07°37'30''	
3. Evenhandedness	07°37'30'' - 08°33'45''	
4. Leadership by example	08°33'45'' - 09°30'00''	
5. Love	09°30'00'' - 10°26'15''	
6. Purpose	10°26'15'' - 11°22'30''	
* 63. Pisces		
After Completion	11°22'30'' - 17°00'00''	Logic
1. Composure	11°22'30'' - 12°18'45''	63 - 4
2. Structuring	12°18'45'' - 13°15'00''	
3. Continuance	13°15'00'' - 14°11'15''	
4. Memory	14°11'15'' - 15°07'30''	
5. Affirmation	15°07'30'' - 16°03'45''	
6. Nostalgia	16°03'45'' - 17°00'00''	
* 22. Pisces		
Grace	17°00'00'' - 22°37'30''	Openness
1. Second class ticket	17°00'00'' - 17°56'15''	22 - 12
2. Charm school	17°56'15'' - 18°52'30''	
3. The enchanter	18°52'30'' - 19°48'45''	
4. Sensitivity	19°48'45'' - 20°45'00''	
5. Directness	20°45'00'' - 21°41'15''	
6. Maturity	21°41'15'' - 22°37'30''	
* 36. Pisces		
The Darkening of the Light	22°37'30'' - 28°15'00''	Transitoriness
1. Resistance	22°37'30'' - 23°33'45''	36 - 35
2. Support	23°33'45'' - 24°30'00''	
3. Transition	24°30'00'' - 25°26'15''	
4. Espionage	25°26'15'' - 26°22'30''	
5. The underground	26°22'30'' - 27°18'45''	
6. Justice	27°18'45'' - 28°15'00''	
* Y 25. Pisces/Aries		
Innocence	28°15'00'' - 03°52'30''	Initiation
1. Selflessness	28°15'00'' - 29°11'15''	25 - 51
2. The existentialist	29°11'15'' - 00°07'30''	
3. Sensibility	00°07'30'' - 01°03'45''	
4. Survival	01°03'45'' - 02°00'00''	
5. Recuperation	02°00'00'' - 02°56'15''	
6. Ignorance	02°56'15'' - 03°52'30''	

The Hexagrams of The I Ching

1. The Creative
2. The Receptive
3. Difficulty at the Beginning
4. Youthful Folly
5. Waiting
6. Conflict
7. The Army
8. Holding Together
9. Taming Power of the Small
10. Treading
11. Peace
12. Standstill
13. Fellowship of Man
14. Possession in Great Measure
15. Modesty
16. Enthusiasm
17. Following
18. Work on What Has Been Spoilt
19. Approach
20. Contemplation
21. Biting Through
22. Grace
23. Splitting Apart
24. Returning
25. Innocence
26. Taming Power of the Great
27. Nourishment
28. Preponderance of the Great
29. The Abyssal
30. The Clinging Fire
31. Influence
32. Duration
33. Retreat
34. The Power of the Great
35. Progress
36. Darkening of the Light
37. The Family
38. Opposition
39. Obstruction
40. Deliverance
41. Decrease
42. Increase
43. Breakthrough
44. Coming to Meet
45. Gathering Together
46. Pushing Upward
47. Oppression
48. The Well
49. Revolution
50. The Cauldron
51. The Arousing
52. Keeping Still
53. Development
54. The Marrying Maiden
55. Abundance
56. The Wanderer
57. The Gentle
58. The Joyous
59. Dispersion
60. Limitation
61. Inner Truth
62. Preponderance of the Small
63. After Completion
64. Before Completion

THE RAVE I CHING

A DIFFERENT INTERPRETATION OF THE BOOK OF CHANGES
BASED ON
THE HUMAN DESIGN SYSTEM

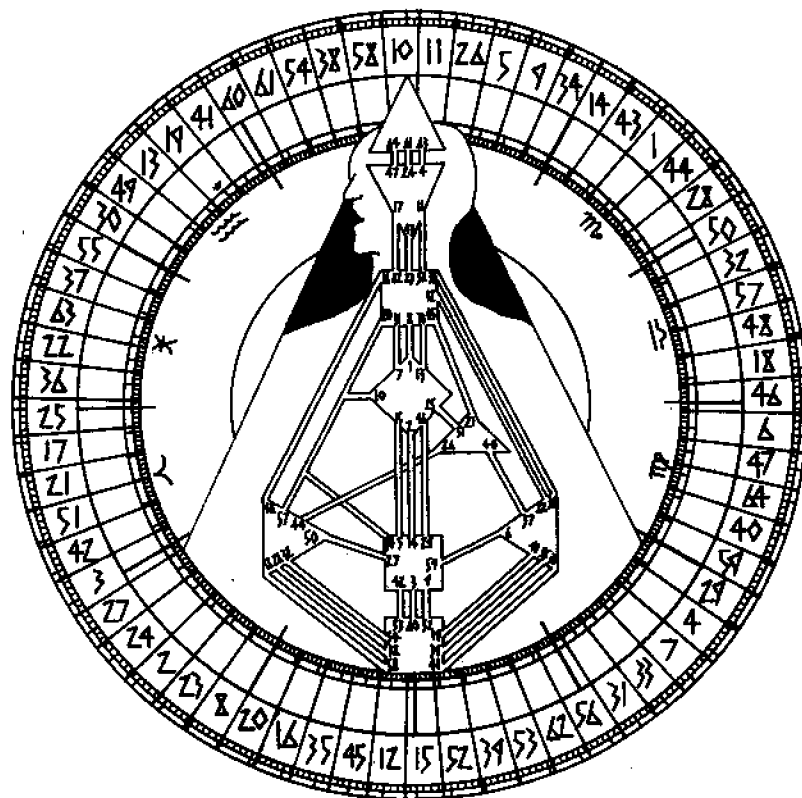

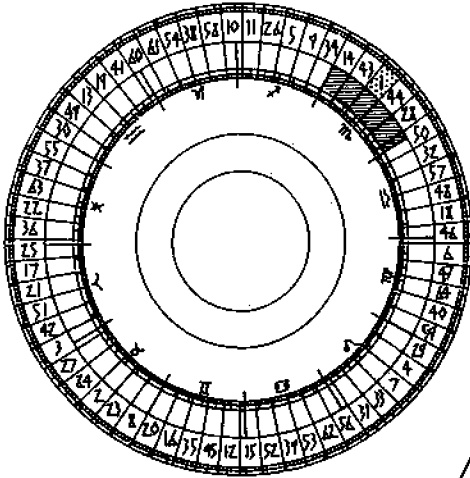

The Creative

13°15'00'' - 18°52'30'' N.

The Lines

- 1-13°15'00'' - 14°11'15''
- 2-14°11'15'' - 15°07'30''
- 3-15°07'30'' - 16°03'45''
- 4-16°03'45'' - 17°00'00''
- 5-17°00'00'' - 17°56'15''
- 6-17°56'15'' - 18°52'30''

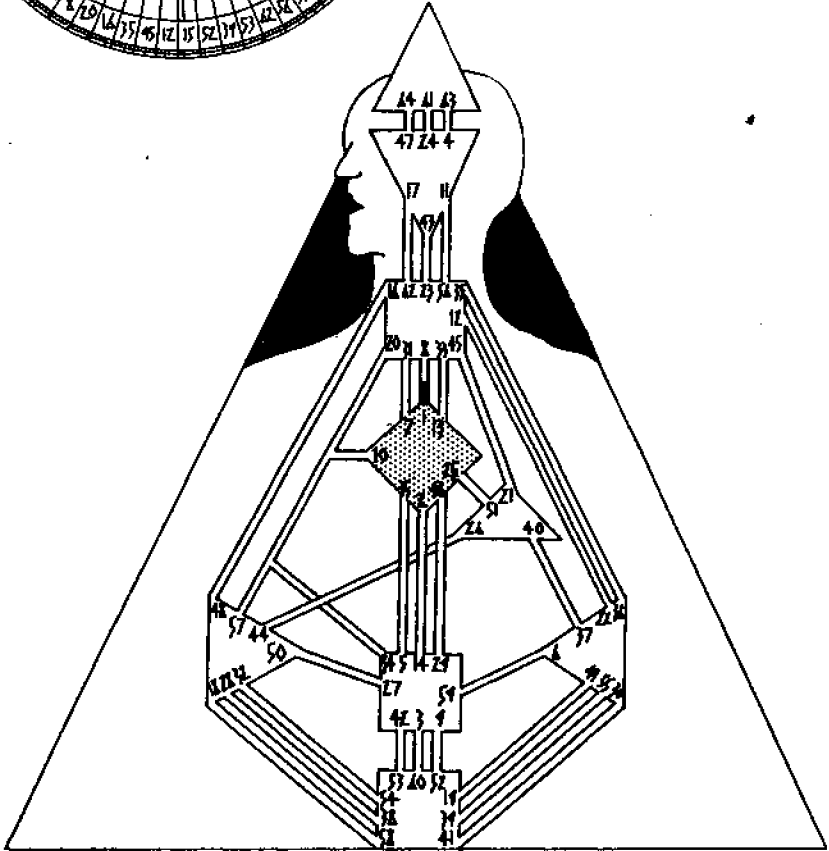

The Creative

Sign: Scorpio-Fixed. Transcendence Sex Death Regeneration

Center: G Center. Spirituality Gravity Attraction Love

Biology: The Liver

Gate: 1 The Creative

Harmonic Gate: 8 Holding Together

Channel: 1-8 Inspiration. The creative Role Model

Creation as a primal force. The energy potential to manifest inspiration without limitation.

The Lines

1 - Creation is independent of will. The Moon exalted as a symbol of adaption. Time is everything. Uranus in detriment. Instability leads to distortion. Here, patience is a virtue and revolution a vice.

2 - Love is light. Venus exalted as a symbol of beauty. The required harmony between established values and ideals that enriches inspiration. Mars in detriment. Desires and passions have their place but not at the expense of Creation.

3 - The energy to sustain creative work. Mars exalted as the symbol of the profound need for self-expression. The Earth in detriment. Material forces can disrupt creativity and lead to overambition.

4 - Aloneness as the medium of creativity. The tension of inner light. The Earth exalted as the symbol of personal perspective manifested outside of influence, where the potential magic of inspiration is diluted. Jupiter in detriment.

5 - The energy to attract society with creation. Mars exalted for its powerful ego endurance. Uranus in detriment, where eccentricity can handicap endurance.

6 - Objectivity. Clear assessment of creative value. The Earth exalted. Pluto in detriment. The risk that subjective appraisal will result in disappointment and creative frustration.

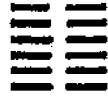
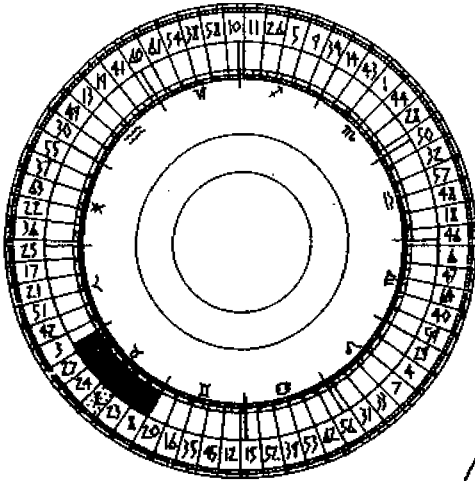

The Receptive

13°15'00'' - 18°52'30'' ♂

The Lines

- 1-13°15'00'' - 14°11'15''
- 2-14°11'15'' - 15°07'30''
- 3-15°07'30'' - 16°03'45''
- 4-16°03'45'' - 17°00'00''
- 5-17°00'00'' - 17°56'15''
- 6-17°56'15'' - 18°52'30''

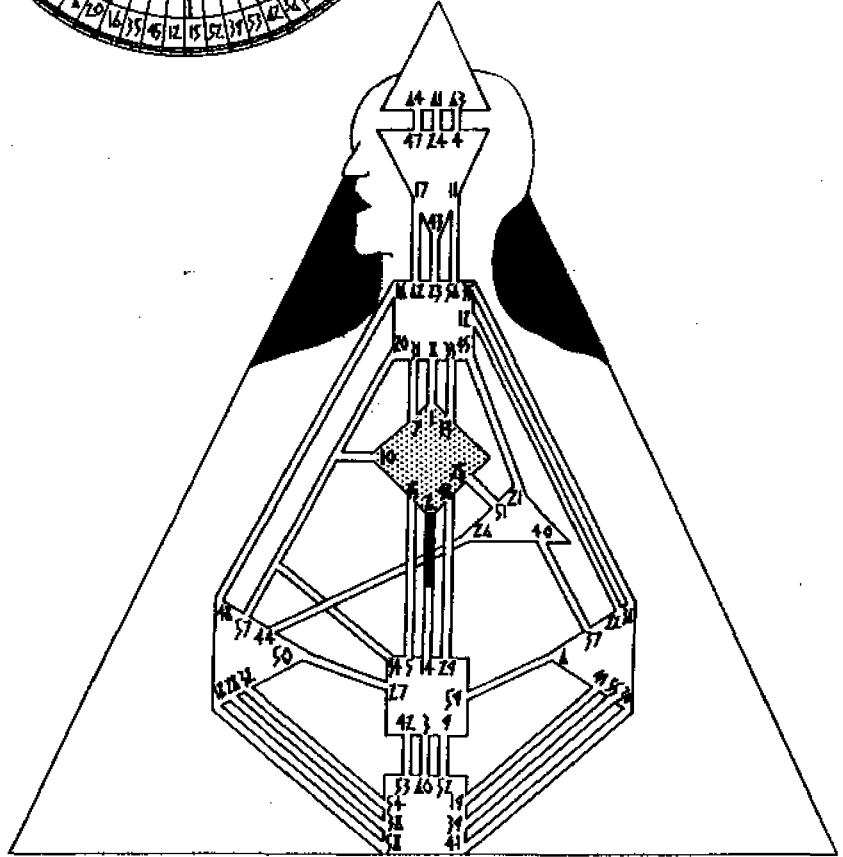

The Receptive

Sign: Taurus-Fixed. Materialism Practicality Inertia

Center: G Center. Spirituality Gravity Attraction Love

Biology: The Liver

Gate: 2 The Receptive

Harmonic Gate: 14 Possession in Great Measure

Channel: 2-14 The Beat. The design of being the keeper of
keys

Receptivity as the primal base through which any
response is determined. The root of action.

The Lines

1 - Intuition. Sensitivity to disharmony and atrophy. Venus exalted. The importance of aesthetics whether inborn or acquired. Mars in detriment. The assertion of ego in spite of wisdom.

2 - Genius. Unconscious and unlearnable alignment of stimulus and response. The natural. Saturn exalted. The inner strength to focus and realize. Mars in detriment. Genius as madness. Knowledge exclusively as power for the enhancement of the ego.

3 - Patience. The teacher that never stops being a student. Jupiter exalted. Dedication to a lifetime of receptivity with the maturity to accept that the process never ends. When connected permanently to Gate 14 through the Beat Channel, rewards for services rendered. Uranus in detriment. For the revolutionary patience is a vice.

4 - Secretiveness. More than modesty, the ability to preserve harmony through discretion. Venus exalted. The higher goal transcends personal acclaim. The team player, acknowledged as the leader but never the captain. Mars in detriment. Loose lips sink ships. The unquenchable fire of the ego engenders enmity.

5 - Intelligent application. The strategist with Mercury exalted. Reasoned management of resources. The Earth in detriment. The inability to share responsibility or recognize the abilities of others.

6 - Fixation. Unable or unwilling to see the whole picture. With Mercury exalted, less negative, though the intellect becomes absorbed in constant rationalization. Saturn in detriment. The need for security may distort awareness to its ultimate perversion, destructiveness.

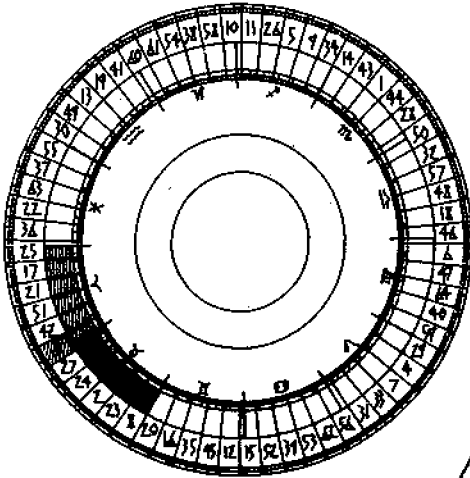

Difficulty at the Beginning

26°22'30'' Y - 02°00'00'' B

The Lines

- 1-26°22'30'' - 27°18'45''
- 2-27°18'45'' - 28°15'00''
- 3-28°15'00'' - 29°11'15''
- 4-29°11'15'' - 00°07'30''
- 5-00°07'30'' - 01°03'45''
- 6-01°03'45'' - 02°00'00''

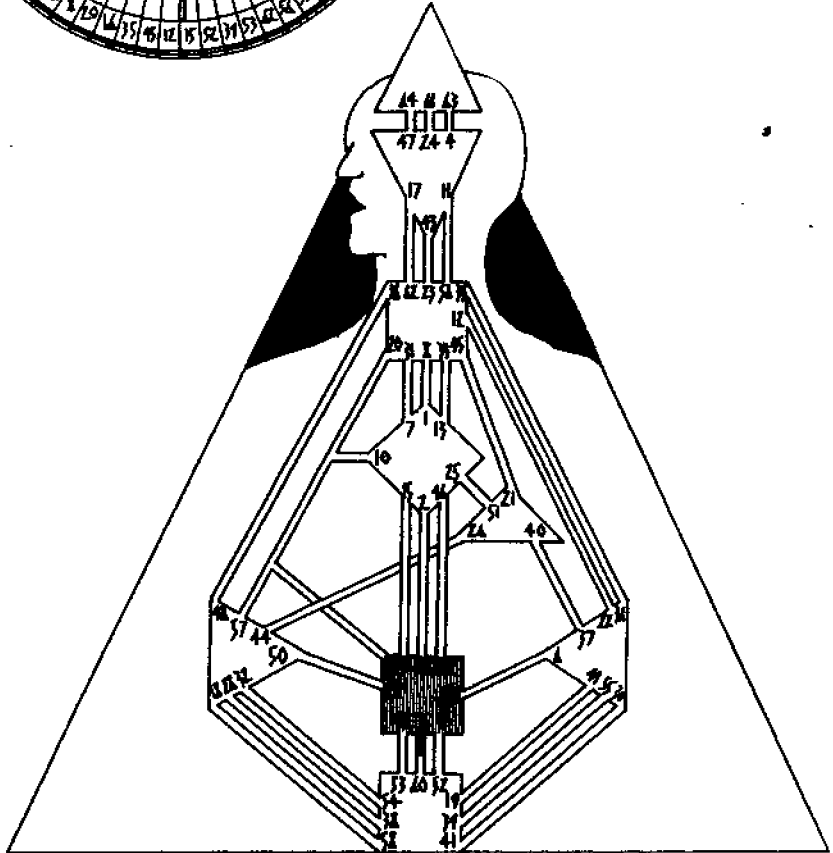

Difficulty at the Beginning

Signs (Cusp Hexagram): Aries-Cardinal. Desire Will Impulse

Taurus-Fixed. Materialism Practicality Inertia

Center: Sacral. Maturation Reproduction Sexuality

Biology: The Ovaries and Testes

Gate: 3 Difficulty at the Beginning

Harmonic Gate: 60 Limitation

Channel: 3-60 Mutation. Energy which fluctuates and initiates

The fundamental challenge of initiation is to transcend confusion and establish order.

The Lines

1 - Synthesis. Difficulties can be only overcome when all the pertinent factors have been analyzed. The Earth exalted. The understanding that confusion is natural and must always exist before clarity can be achieved. Mercury in detriment. The reliance on intellect at the expense of intuition can lead to unnecessary frustration.

2 - Immaturity. The unrestrained acceptance of guidance. Mars exalted. The unrelenting energy for growth will eventually triumph. Uranus in detriment. Internal instability which both accepts and rejects authority simultaneously.

3 - Survival. The ability to recognize and distinguish between fertile and sterile in their various manifestations. Venus exalted. In reproduction, the ability to choose the best mate. Pluto in detriment is the perverse denial of evolutionary standards.

4 - Charisma. Innate quality which attracts valued guidance. Neptune exalted. Psychic attunement that magnetizes nurturing. Mars in detriment, where the demands of ego lead to rejection.

5 - Victimization. When actions designed to overcome confusion alienate others. Mars exalted. The courage to stand by one's convictions. The Earth in detriment, where victimization leads to appeasement and suffering.

6 - Surrender. The ultimate maturity to recognize when struggle is futile. The Sun exalted. As its light sustains, so life goes on. Pluto in detriment. As darkness overwhelms, life can seem worthless leading to depression and the sense of hopelessness.

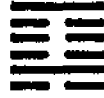
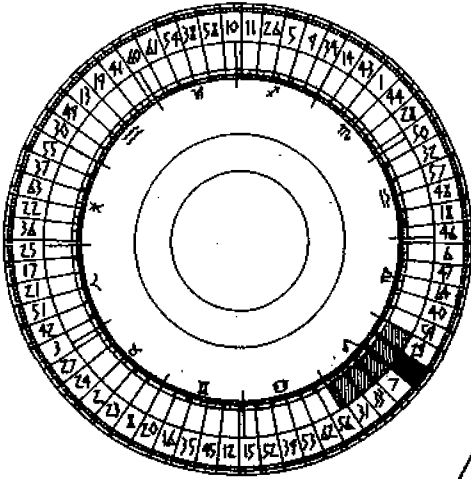

Youthful Folly

18°52'30'' - 24°30'00'' ♂

The Lines

- 1-18°52'30'' - 19°48'45''
- 2-19°48'45'' - 20°45'00''
- 3-20°45'00'' - 21°41'15''
- 4-21°41'15'' - 22°37'30''
- 5-22°37'30'' - 23°33'45''
- 6-23°33'45'' - 24°30'00''

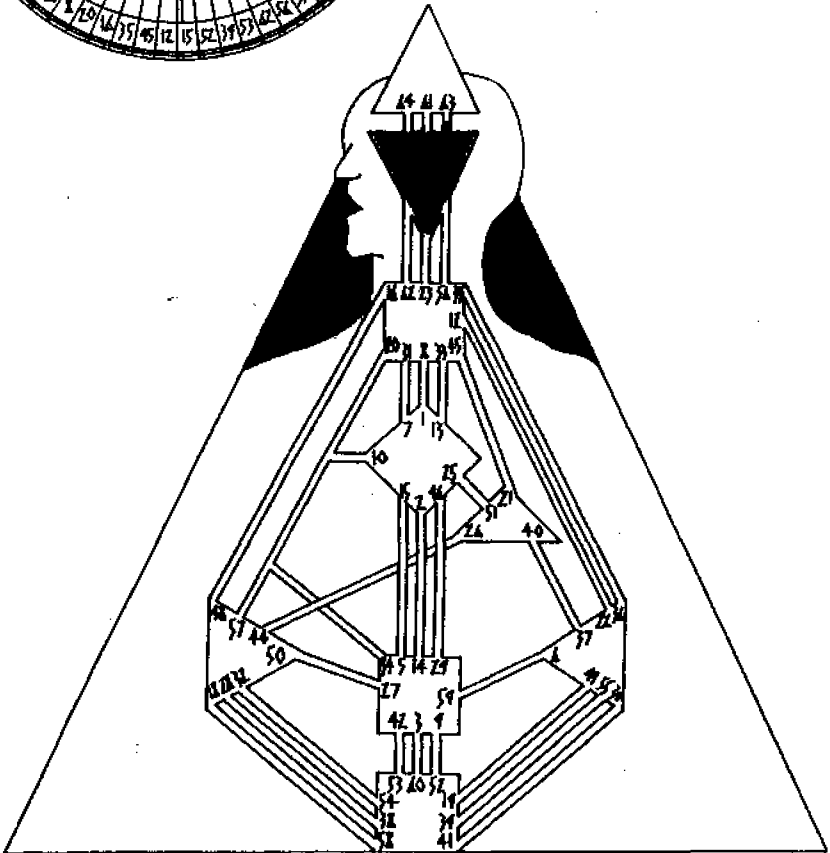

Youthful Folly

Sign: Leo-Fixed. Self-expression Pleasure Authority

Center: Ajna. Knowing Intuition Understanding

Biology: Anterior and Posterior Pituitary Glands

Gate: 4 Youthful Folly

Harmonic Gate: 63 After Completion

Channel: 4-63 Logic. A design of mental ease mixed with
doubt

The energy to beguile and succeed despite ignorance.
Freedom from retribution.

The Lines

1 - Pleasure. Ultimate pleasure cannot be achieved without perfect timing. The Moon exalted. The instinct to know the right moment and circumstances where pleasure is rewarded and not punished. The Earth in detriment. Timing is not a product of discipline. Exaggerated self-discipline leads to the abuse of pleasure.

2 - Acceptance. The recognition of limitation in oneself and others leads to tolerance and the suspension of judgment. The Moon exalted. The glorification of feelings. The mother which always pardons the errant child. Mars in detriment. The assertion of the ego at the expense of others' failures.

3 - Irresponsibility. The general refusal to apply oneself diligently when one can get by with much less effort. Venus exalted. Where art is more valued than the artist. Pluto in detriment. The rationalization of irresponsibility as an act of refocalization.

4 - The Liar. Role playing as an art form. The actor. The Sun exalted. Fantasy protects and nurtures a sense of purpose and reason no matter how misguided. Saturn in detriment. Time always brings humiliation.

5 - Seduction. Allowing others to assume responsibility as a shield against potential punishment. Jupiter exalted. Unearned reward and recognition. Pluto in detriment. A life of lip service to antiquated and unsatisfying values. Cynicism.

6 - Excess. Repeated and conscious abuse of norms will not escape discipline. Mercury exalted. The development through experience of techniques to apply self-restraint. Mars in detriment. The gall to accept punishment as the price of excess.



Waiting

11°22'30" - 17°00'00" ♀

The Lines

- 1-11°22'30" - 12°18'45"
- 2-12°18'45" - 13°15'00"
- 3-13°15'00" - 14°11'15"
- 4-14°11'15" - 15°07'30"
- 5-15°07'30" - 16°03'45"
- 6-16°03'45" - 17°00'00"

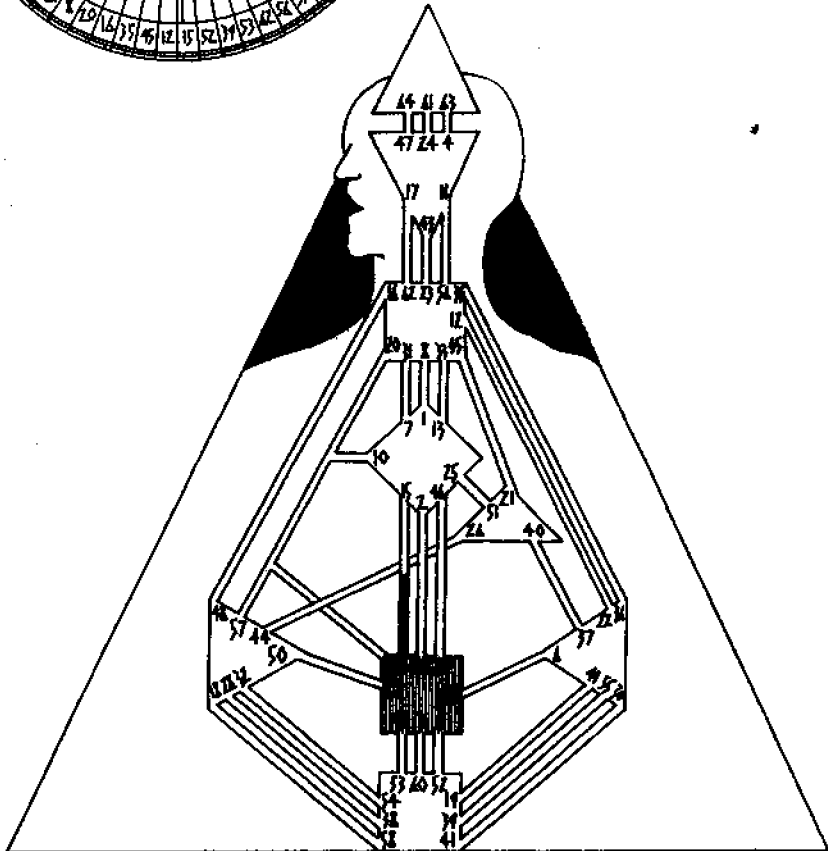
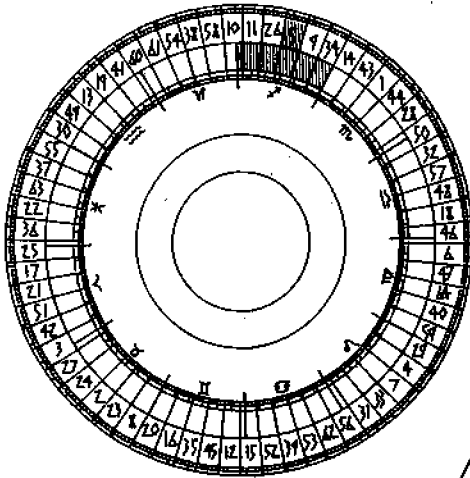

Waiting

Sign: Sagittarius-Mutable. Philosophy Religion Idealism

Center: Sacral. Maturation Reproduction Sexuality

Biology: The Ovaries and Testes

Gate: 5 Waiting

Harmonic Gate: 15 Modesty

Channel: 5-15 Rhythm. The design of being in the flow

The fundamental attunement to natural rhythms. Waiting as an active state of awareness.

The Lines

1 - Perseverance. If the captain must, he goes down with the ship. Mars exalted. Courage in the face of adversity. The Earth in detriment. The premature and often disastrous urge to cut one's losses.

2 - Inner peace. The ability to ignore the temptation to take premature action. Venus exalted. The gift of maintaining composure through idealizing tranquility. Pluto in detriment. Inner peace experienced as stagnation.

3 - Compulsiveness. The fear engendered by the sense of helplessness resulting in unnecessary stress and activity. Neptune exalted. Compulsiveness can be limited in its negative effect through flights of imagination. Though still stressful, they do not lead to action. The Moon in detriment. The Moon cannot stand still.

4 - The Hunter. Waiting as a guarantee of survival. Uranus exalted. The creative genius to transform the most passive experience into active achievement. The Sun in detriment. The vanity of a personality so strong that unwilling to hide behind a blind, threatens its very survival.

5 - Joy. Waiting as an aspect of enlightenment. Venus exalted. To remain calm as the ultimate aesthetic and thus recognize the inner meaning of being. Pluto in detriment. Joy dismissed as an illusion, waiting as a failure.

6 - Yielding. Waiting is never free from pressure, physical or mental and is often punctuated by the unexpected. Neptune exalted. The growth of awareness that comes with bending to the universal flow. There is no planet in detriment; each in its way, given the power of this position, will yield to the inevitable.

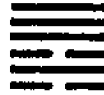
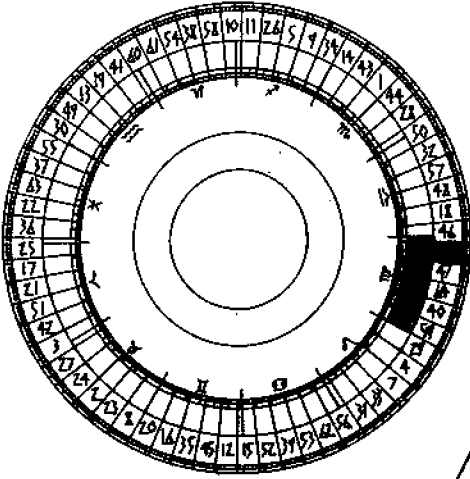

Conflict

22°37'30'' - 28°15'00'' 117

The Lines

- 1-22°37'30'' - 23°33'45''
- 2-23°33'45'' - 24°30'00''
- 3-24°30'00'' - 25°26'15''
- 4-25°26'15'' - 26°22'30''
- 5-26°22'30'' - 27°18'45''
- 6-27°18'45'' - 28°15'00''

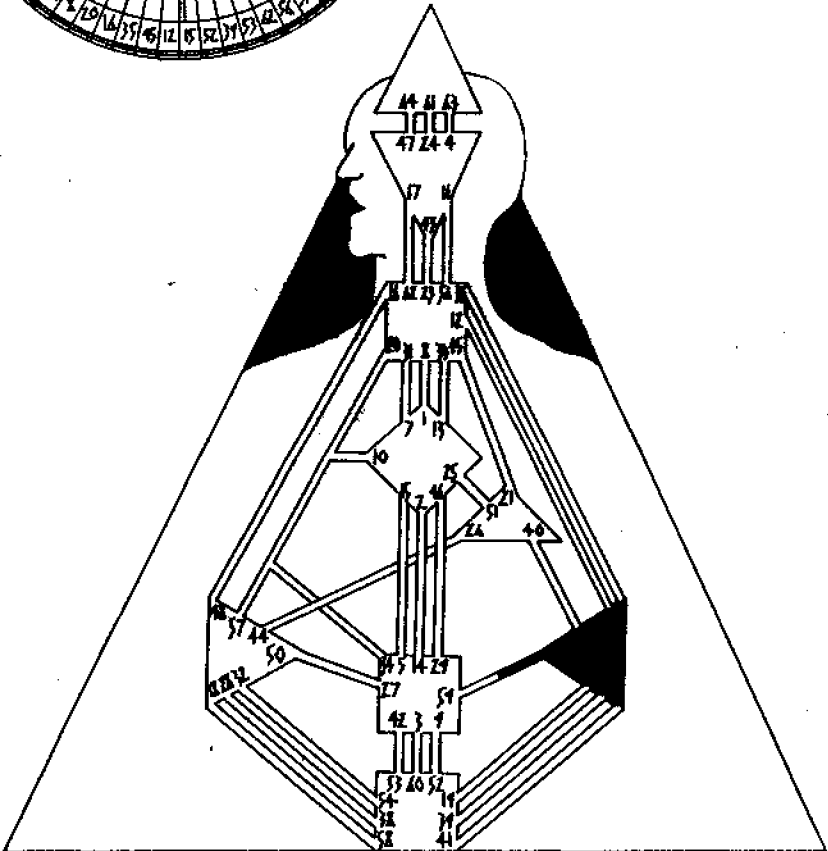

Conflict

Sign: Virgo-Mutable. Mental detail Service Judgmentation

Center: Solar Plexus. Aspiration Sensitivity Emotion

Biology: Kidney Pancreas

Gate: 6 Conflict

Harmonic Gate: 59 Dispersion

Channel: 6-59 Mating. A design focused on reproduction

The fundamental design component of progress. The law that growth cannot exist without friction.

The Lines

1 - Retreat. The realization that wasting one's resources against overwhelming odds is not courage but folly. Pluto exalted. The power of regeneration that can embrace retreat as a phase and not a failure. Mercury in detriment. The inferiority complex, where retreat is experienced as personal weakness.

2 - The guerrilla. The ability to maximize an inferior position through timely contact and withdrawal. Venus exalted. Aesthetic sensitivity and mental detail can find the weakest point. Mars in detriment. The kamikaze, striking but moot.

3 - Allegiance. The ability to secure support and create strength out of a weak position. When connected to the harmonic Gate 59, mating that results in conception. Neptune exalted. The destruction of old forms through union; either mundane, as above, sexual union, or exalted as universalization. Pluto in detriment. The rejection of allegiance as submission to established order.

4 - Triumph. A position on natural and unchallengeable power. The Sun exalted. The charity and wisdom that must come with victory and the movement towards new horizons. Pluto in detriment. The conqueror and purger.

5 - Arbitration. The faith derived from analytical diligence and emotional control that permits a higher authority to judge a conflict. Venus exalted. Harmony furthered through the avoidance of direct conflict. The Moon in detriment, where a party to arbitration sees itself as the best possible judge and will only accept judgment if it is the victor.

6 - The peacemaker. The discipline and integrity of a superior force to unilaterally cease conflict to permit surrender and survival of its foe. Mercury exalted. The highest form of reason is that life is sacred. Venus in detriment. The peacemaker whose actions are just but whose terms are unacceptable.

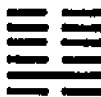
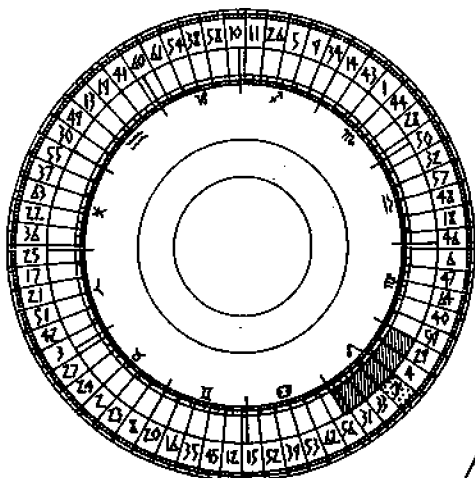

The Army

13°15'00'' - 18°52'30'' ☰

The Lines

- 1-13°15'00'' - 14°11'15''
- 2-14°11'15'' - 15°07'30''
- 3-15°07'30'' - 16°03'45''
- 4-16°03'45'' - 17°00'00''
- 5-17°00'00'' - 17°56'15''
- 6-17°56'15'' - 18°52'30''

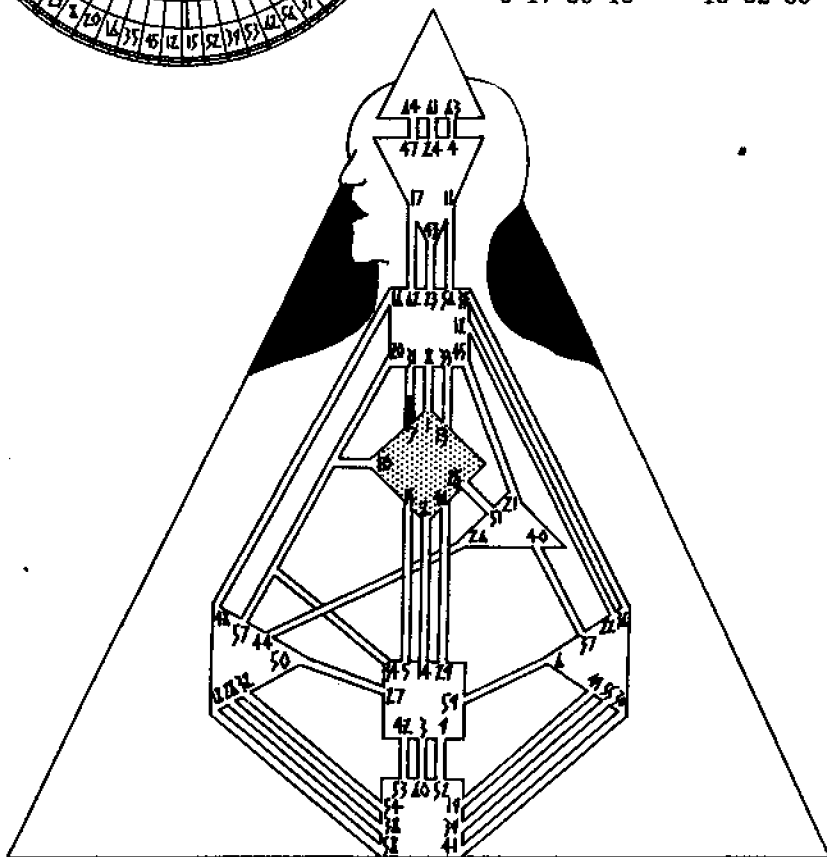

The Army

Sign: Leo-Fixed. Self-expression Pleasure Authority

Center: G Center. Spirituality Gravity Attraction Love

Biology: The Liver

Gate: 7 The Army

Harmonic Gate: 31 Influence'

Channel: 7-31 The Alpha. For 'good' or 'bad' the design of leadership

The point of convergence. By design, the need for leadership to guide and order society.

The Lines

1 - Authoritarian. The iron hand both enlightened and despotic. Venus exalted, as in the basic values and rules imposed on a child. Mercury in detriment. The distorted intellect that believes only it knows best.

2 - The democrat. The ability to lead by serving the will of the majority. Neptune exalted. The application of universally accepted systems. When connected through the Alpha Channel to Gate 31 Influence, the potential for widespread and revolutionary effect on society. Mercury in detriment. Elitism and denegation by democrats of democracy.

3 - The anarchist. The rejection of any institutionalized order. The Moon exalted. The constant need for change no matter what the prevailing conditions. Mercury in detriment. The nihilist.

4 - The abdicator. The willingness to accept the judgment of the people and/or the rule of law. The Sun exalted. The grace and wisdom to step down for the benefit of the whole. Uranus in detriment. One who must be forced from power by overwhelming opposition.

5 - The general. Leadership whose authority must be absolute and is sanctioned by society in times of crisis. Venus exalted. The gift of attracting loyalty necessary in harmonizing the potential of society. Neptune in detriment. The commander isolated from his troops and obsessed with victory at any price.

6 - The administrator. The ability to share and justly apportion power. Mercury exalted. The power to communicate the frameworks of responsibility. Uranus in detriment. The bureaucrat whose lust for power eventually destabilizes the organisation.

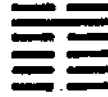
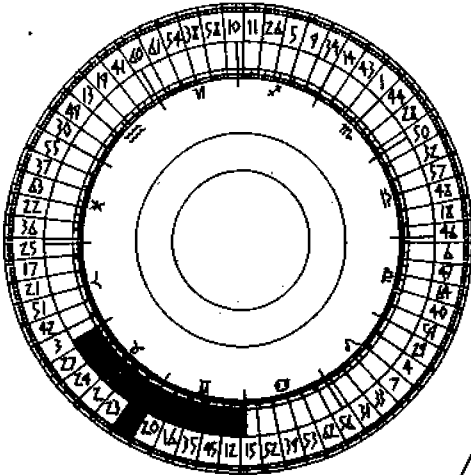

Holding Together

24°30'00'' ☽ - 00°07'30'' ♀

The Lines

- 1-24°30'00'' - 25°26'15''
- 2-25°26'15'' - 26°22'30''
- 3-26°22'30'' - 27°18'45''
- 4-27°18'45'' - 28°15'00''
- 5-28°15'00'' - 29°11'15''
- 6-29°11'15'' - 00°07'30''

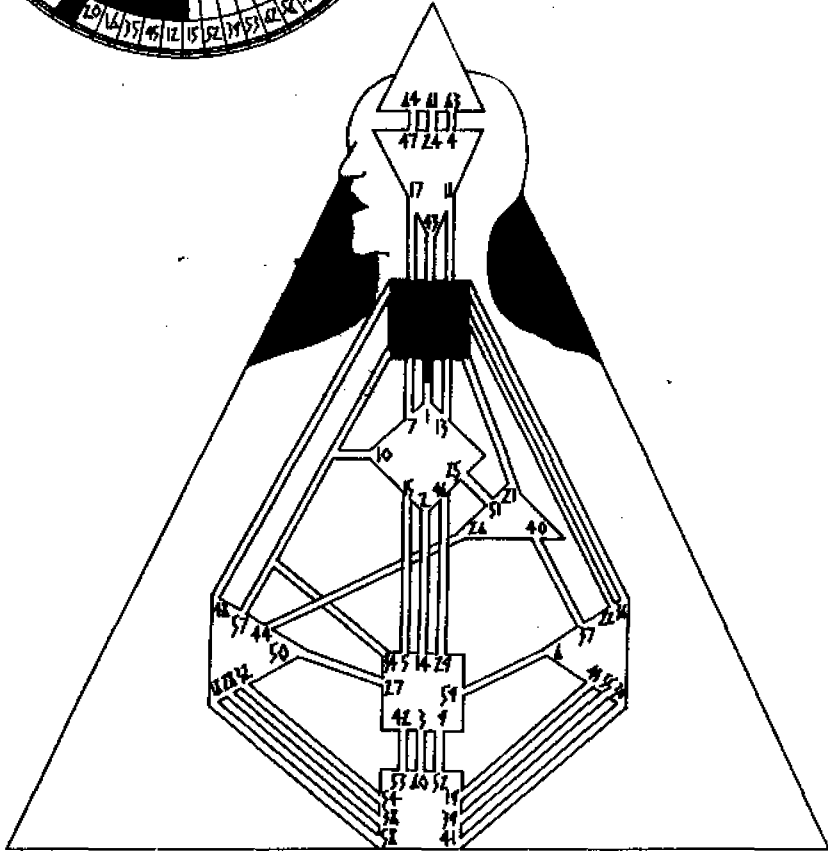

Holding Together

Sign (Cusp Hexagram): Taurus-Fixed. Materialism Practicality
Inertia

Gemini-Mutable. Changeability Duality Expansion

Center: Throat. Action Metamorphosis Unfolding

Biology: The Thyroid and Parathyroid Glands

Gate: 8 Holding Together Harmonic Gate: 1 The Creative

Channel: 8-1 Inspiration. The creative Role Model

The basic worth realized in contributing individual efforts to group goals.

The Lines

1 - Honesty. The truthful acceptance of limitation and recognition that it can only be transcended through sharing. Neptune exalted. The awareness that the whole is always greater than the sum of its parts. Mercury in detriment. Withdrawal. The fear of losing individuality in a group environment.

2 - Service. The Sun exalted. The highest good, to serve selflessly. The earth in detriment, where reward is a prerequisite of service.

3 - The phoney. The acceptance of the style and not the substance of communal actions. The Moon exalted. The perfected, and rarely detected superficial intimacy. Saturn in detriment. A shallowness that underestimates others and overestimates its own ability to continue its deception without detection.

4 - Respect. The gift of naturally recognizing the contributions of others and particularly, the acknowledgement of those who lead by example. Jupiter exalted. The uncompromizing drive to assimilate. Mercury in detriment. In a group where limitation is transcended, reason alone cannot predict individual worth. As an example, the acknowledged leader of an athletic team is not necessarily the most talented.

5 - Dharma. Holding together does not exclude eventual separation. Successful union, after a proper term will encourage separation. The fledgling once mature is expected to leave the nest. This is right action which does not harm the integrity of the union. Jupiter exalted. The teacher. The Sun in detriment. The parent that cannot let go of the child, understanding only, that its authority is being challenged.

6 - Communion. The certainty which grows out of harmony. Venus exalted. The awareness of patterns that ensures correct timing. Pluto in detriment. Doubt, which may engender regret even in the most ideal circumstances.

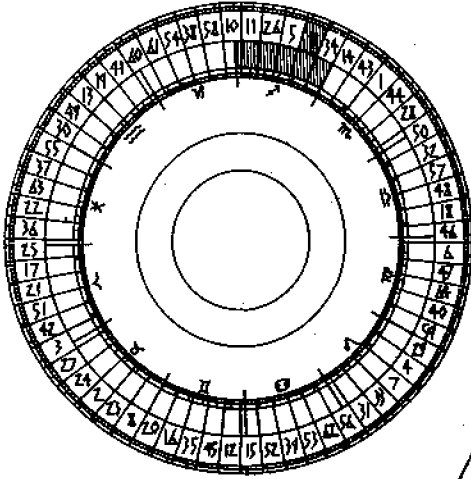

The Taming Power of the Small

05°45'00'' - 11°22'30'' ↗

The Lines

- | | |
|--------------|--------------|
| 1-05°45'00'' | - 06°41'15'' |
| 2-06°41'15'' | - 07°37'30'' |
| 3-07°37'30'' | - 08°33'45'' |
| 4-08°33'45'' | - 09°30'00'' |
| 5-09°30'00'' | - 10°26'15'' |
| 6-10°26'15'' | - 11°22'30'' |

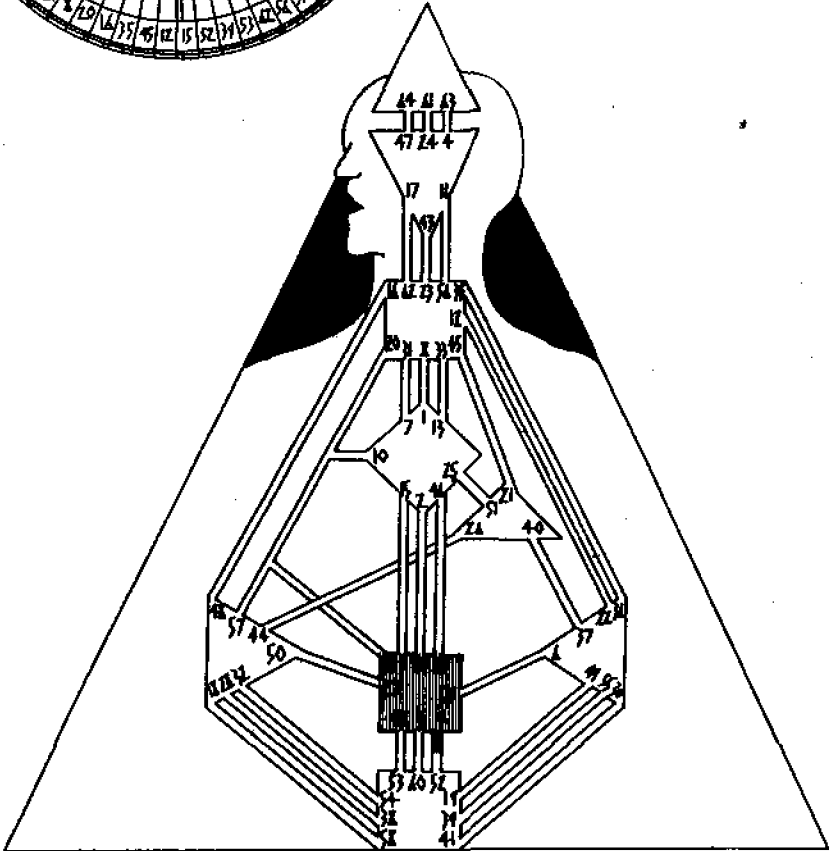

The Taming Power of the Small

Sign: Sagittarius-Mutable. Philosophy Religion Idealism

Center: Sacral. Maturation Reproduction Sexuality

Biology: The Ovaries and Testes

Gate: 9 Taming Power of the Small

Harmonic Gate: 52 Keeping Still

Channel: 9-52 Concentration. A design of determination

Potential can be fulfilled through detailed attention to all pertinent aspects.

The Lines

1 - Sensibility. A balanced and responsible approach to problem solving. Pluto exalted. The ability to avoid frustration through the creation of new forms. Mars in detriment. After a hasty and frustrating search the urge to kick in the door when the key is in your pocket.

2 - Misery loves company. Pluto exalted. Collaboration with others to temper frustration. Jupiter in detriment. The overwhelming need for expansion can lead to errors in judgment, missed opportunities and depression.

3 - The straw that breaks the camel's back. The overlooked minor element that always predetermines failure. The Earth exalted. The use of force to temporarily overcome impediments. The Sun in detriment. Persistent force that saps vitality and turns molehills into mountains.

4 - Dedication. Regardless of the pressures or stress the disciplined attention to detail. The Moon exalted. Right action that leads inevitably to actualization. Mars in detriment. The persistent urge to want to skip essential steps.

5 - Faith. The trust that detailed adherence will lead to fulfillment. Jupiter exalted. Loyalty to the letter of the law. The Earth in detriment. Like the mystery of God, doubt engendered through the perceived illogic of a process.

6 - Gratitude. The joy which comes with accepting small rewards for small victories. The Moon exalted, where the power of the small nourishes right perspective. Pluto in detriment. No single step is of value until the journey is over.

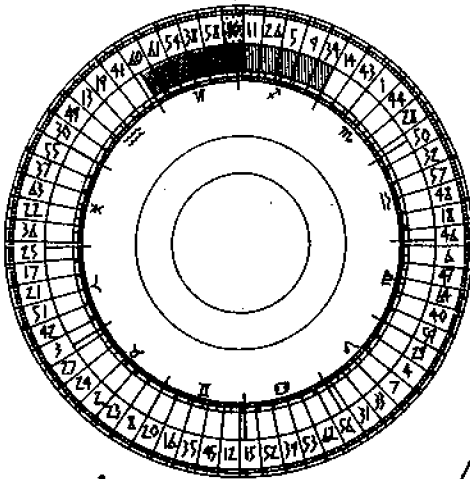

Treading

28°15'00'' - 03°52'30''

The Lines

- 1-28°15'00'' - 29°11'15''
- 2-29°11'15'' - 00°07'30''
- 3-00°07'30'' - 01°03'45''
- 4-01°03'45'' - 02°00'00''
- 5-02°00'00'' - 02°56'15''
- 6-02°56'15'' - 03°52'30''

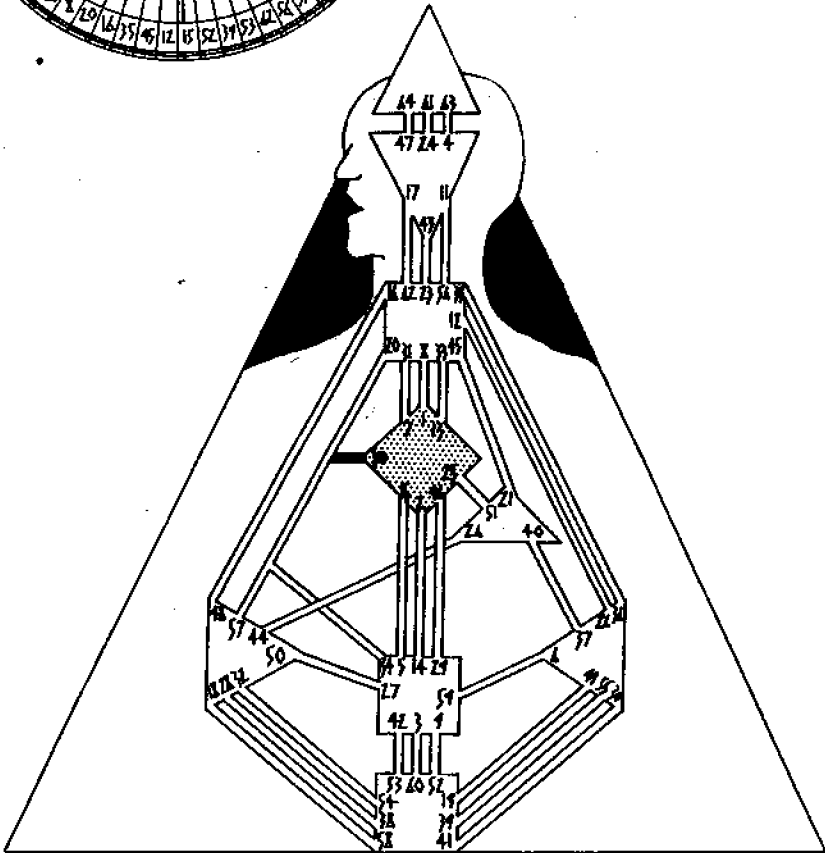

Treading

Sign (Cusp Hex.): Sagittarius-Mutable. Philosophy Religion
Idealism
Capricorn-Cardinal. Ambition Government Status

Center: G Center. Spirituality Gravity Attraction Love

Biology: The Liver

Gate: 10 Treading

Harmonic Gates: 20 Contemplation
34 The Power of the Great
57 The Gentle

Channels:

10-20 Awakening. A design of commitment to higher principles
10-34 Exploration. A design of following ones convictions
10-57 Perfected form. A design of survival

The underlying code of behaviour which ensures successful interaction despite circumstances.

The Lines

1 - Modesty. An innate sense to know and accept one's place. The Sun exalted. A valued sense of purpose no matter what the position. The Moon in detriment. The affliction of oversensitivity and hurt feeling.

2 - The Hermit. The successful side-stepping of behavioral requirements through isolation. Mercury exalted, where mental functions enrich aloneness. Mars in detriment. The angry exile.

3 - The Martyr. The futile rejection of standards based on a just awareness. The Earth exalted. The martyr as an enduring example whose behaviour is ultimately enshrined. The Moon in detriment. The martyr complex. The active pursuit of martyrdom for personal aggrandizement.

4 - The Opportunist. The acceptance of norms until a successful transformation can be engendered. Uranus exalted. Transformation that is transcendence to a higher code. Mercury in detriment. Opportunism as a game and/or mental exercise.

5 - The Heretic. Direct and overt challenge to norms. Jupiter exalted. The ability to succeed through the understanding and expression of higher principles. Mars in detriment. The burning at the stake.

6 - The Role Model. The perfect expression of the norms through action rather than words. Pluto exalted. The constant example that refocuses the complacent on the basic integrity of set behaviour. Saturn in detriment. The hypocrite. Do as I say, not as I do.

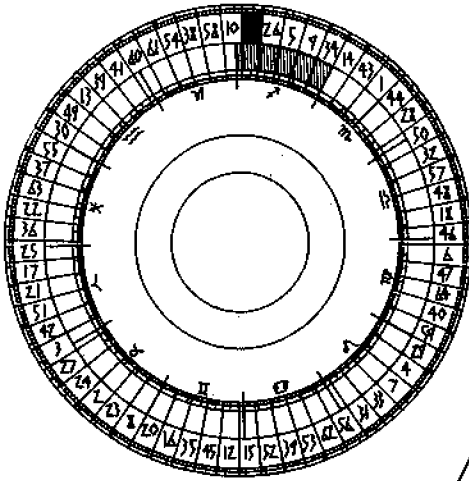

Peace

22°37'30'' - 28°15'00'' ↗

The Lines

- 1-22°37'30'' - 23°33'45''
- 2-23°33'45'' - 24°30'00''
- 3-24°30'00'' - 25°26'15''
- 4-25°26'15'' - 26°22'30''
- 5-26°22'30'' - 27°18'45''
- 6-27°18'45'' - 28°15'00''

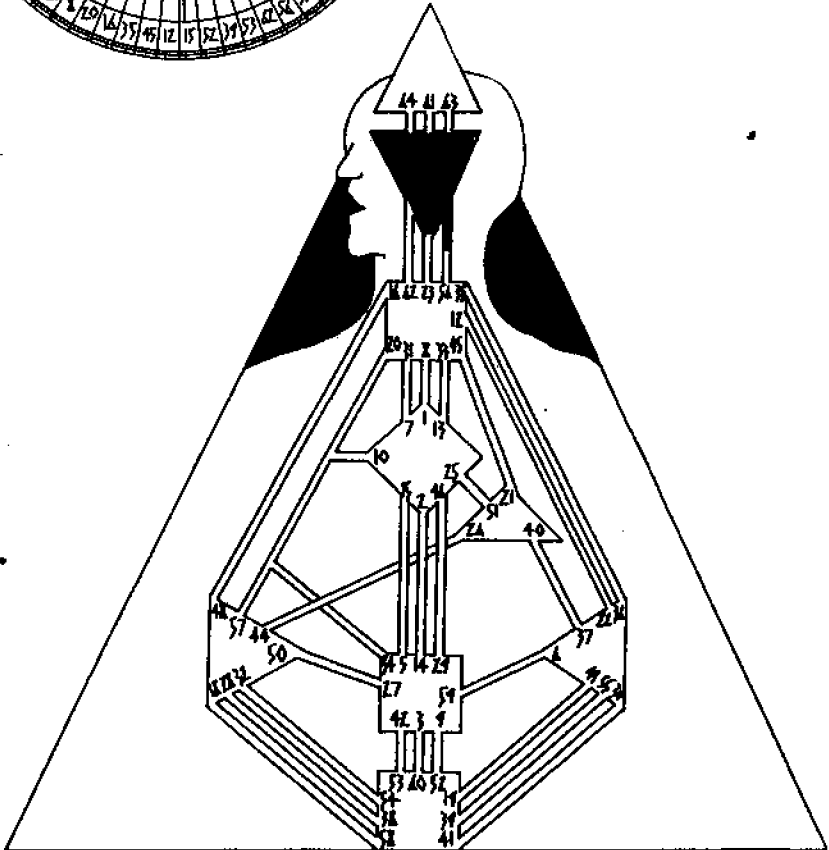

Peace

Sign: Sagittarius-Mutable. Philosophy Religion Idealism

Center: Ajna. Knowing Intuition Understanding

Biology: The Anterior and Posterior Pituitary Glands

Gate: 11 Peace

Harmonic Gate: 56 The Wanderer

Channel: 11-56 Curiosity. The design of the searcher

A harmonic condition in the individual or society that permits assessment before renewed action.

The Lines

1 - Attunement. The serendipity of being in the right place at the right time. The Moon exalted. The nourishment derived from being with those who share the same goals and aspirations. Mars in detriment. The fear of anonymity.

2 - Rigour. The recognition that without vigilance and risk, peace can lead to stagnation and collapse. Neptune exalted. The imagination applied to ensuring the understanding of achieved values. Mars in detriment. The resorting to factionalism to satisfy the ego's need for action.

3 - The Realist. The acknowledgment that peace is transitory. Pluto exalted. The internal renewal to maintain strength and alertness. Venus in detriment. The tendency to appreciate harmony to the point of delusion. The belief that beauty is eternal. Fiddling while Rome burns.

4 - The Teacher. The ability to express the essential nature of peace. The Moon exalted. The sage, that in the extreme, can teach harmony to the tone deaf. Venus is also exalted. The ability to reach out and attract the alienated. The Sun in detriment. The Guru, whose most valued wisdom is intentionally limited to a few.

5 - The Philanthropist. The Moon exalted. The motiveless nurturing of the disenfranchised to ensure harmony. Mercury in detriment. The withdrawing from direct contact, where giving is a form of defence.

6 - Adaptability. The inner balance to accept transition. Neptune exalted. The innate awareness that all forms are transitory. Jupiter in detriment. Adaptability in its most negative manifestation. The speculator who profits at the expense of others in times of peace or war.

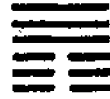
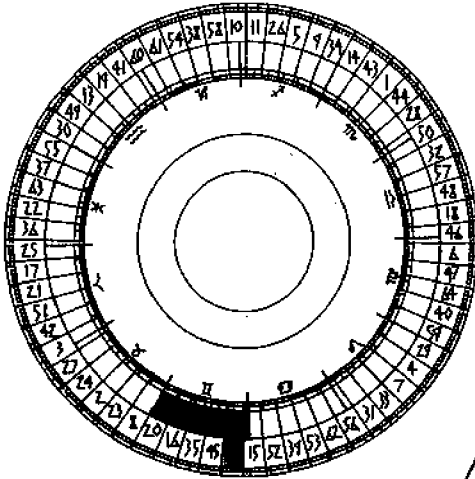

Standstill

22°37'30'' - 28°15'00'' II

The Lines

- 1-22°37'30'' - 23°33'45''
- 2-23°33'45'' - 24°30'00''
- 3-24°30'00'' - 25°26'15''
- 4-25°26'15'' - 26°22'30''
- 5-26°22'30'' - 27°18'45''
- 6-27°18'45'' - 28°15'00''

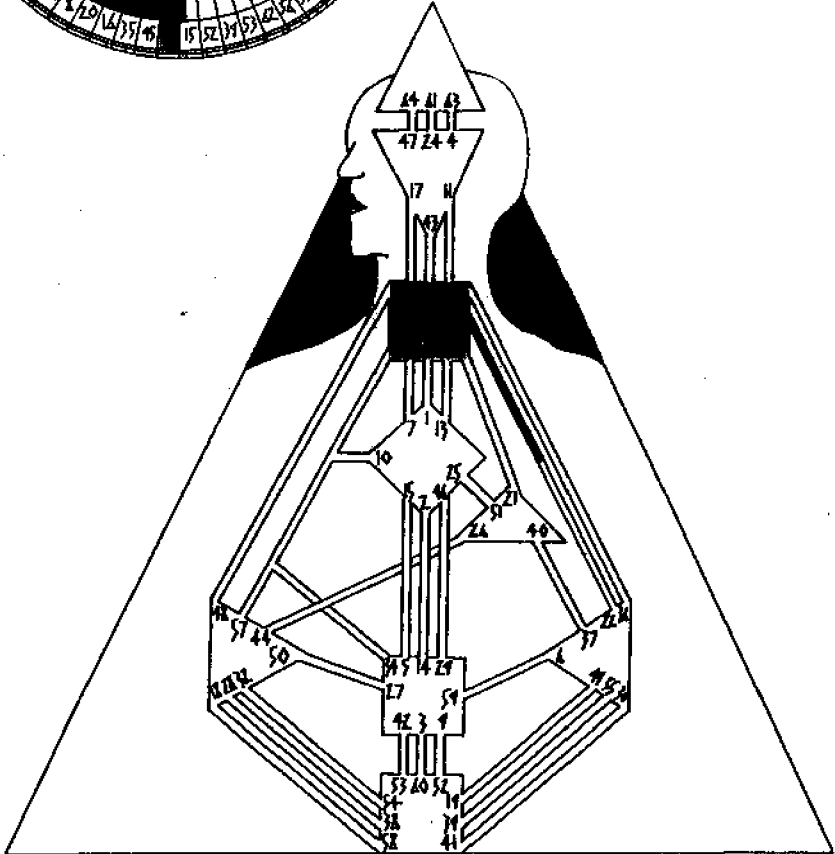

Standstill

Sign: Gemini-Mutable. Changeability Duality Expansion

Center: Throat. Action Metamorphosis Unfolding

Biology: The Thyroid and Parathyroid Glands

Gate: 12 Standstill

Harmonic Gate: 22 Grace

Channel: 12-22 Openness. The design of the social being

The quality of restraint and the importance of meditation and inaction in confronting temptation.

The Lines

1 - The Monk. Withdrawal that can only be maintained with communal support. Venus exalted. The beauty and harmony possible beyond the reach of temptation. Jupiter in detriment. Simon the Stylite, total and often absurd withdrawal.

2 - Purification. Rigorous withdrawal from negative influences. Saturn exalted. The discipline to maintain a pure state. Mercury in detriment. The boredom that arises out of lack of stimulation.

3 - Confession. The process of self-analysis. Neptune exalted. The recognition of inadequacies and the purging of unjustified vanities. Mars in detriment. A perverse and often exaggerated self-hatred.

4 - The Prophet. The ability to foresee and plan for the end of standstill. The Earth exalted. The rousing of the stagnant for communal preparation. Mercury in detriment. The voice in the wilderness.

5 - The Pragmatist. The success of restraint lies in not abandoning the lessons learnt when the phase ends. The Sun exalted. Light is always conscious of darkness. Mars in detriment. The tendency to remember only the most painful lessons learnt.

6 - Metamorphosis. Faith in, and energy applied towards change and the emergence from standstill. The Sun exalted. Creative transcendence that when connected to the Harmonic Gate 22, through the channel of Openness, leads to successful mutation and the emergence of a new social form. The Earth in detriment. A retrograde metamorphosis that has evolved a perfected adaption to standstill.

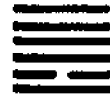
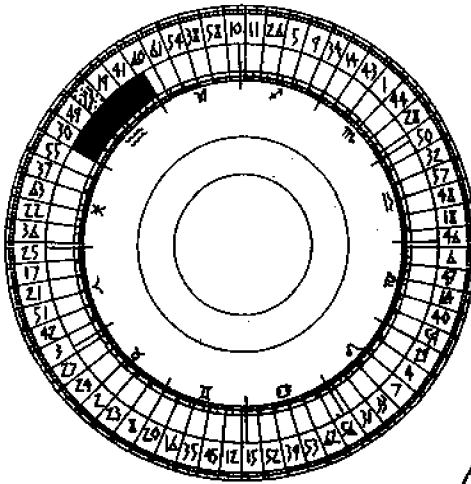

The Fellowship of Man

13°15'00'' - 18°52'30'' ☵

The Lines

- 1-13°15'00'' - 14°11'15''
- 2-14°11'15'' - 15°07'30''
- 3-15°07'30'' - 16°03'45''
- 4-16°03'45'' - 17°00'00''
- 5-17°00'00'' - 17°56'15''
- 6-17°56'15'' - 18°52'30''

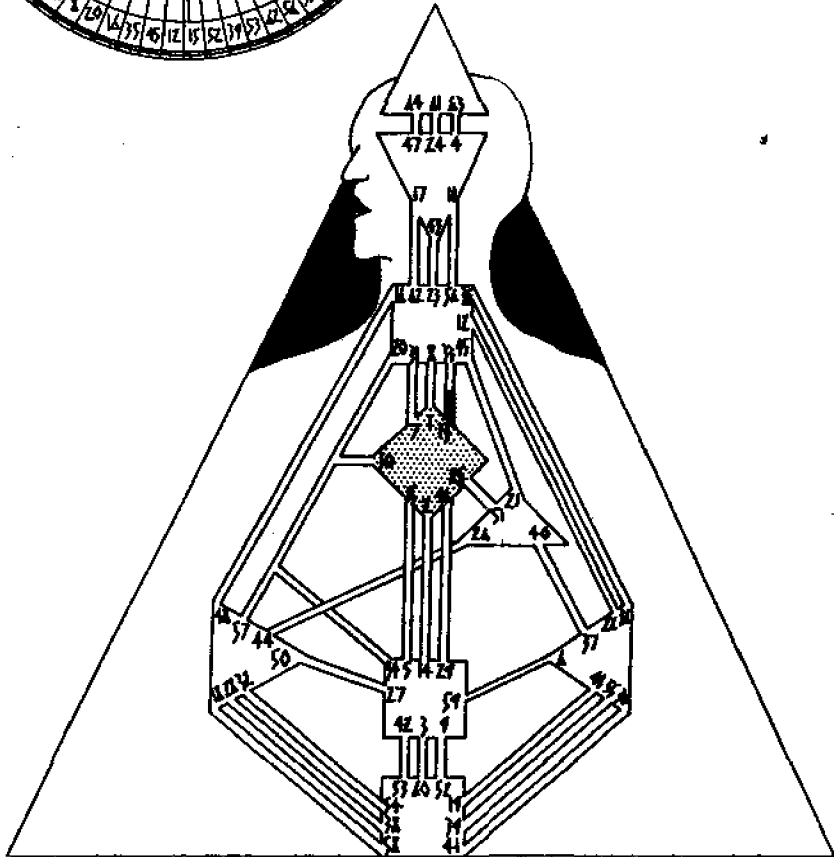

The Fellowship of Man

Sign: Aquarius-Fixed. Science Humanitarianism Music

Center: G Center. Spirituality Gravity Attraction Love

Biology: The Liver

Gate: 13 Fellowship of Man

Harmonic Gate: 33 Retreat

Channel: 13-33 The Prodigal. The design of the witness

Universal ideas and values in an ordered framework
which inspires humanistic cooperation.

The Lines

1 - Empathy. The ability to relate and commune with everyone with equanimity. Venus exalted. Harmony through affection. The Moon in detriment. The politician kissing babies.

2 - Bigotry. The risk, always present, that fellowship can only exist for a particular type, whether racial, religious, national or intellectual. The Moon exalted. Tolerance as the least offensive manifestation of bigotry. The Sun in detriment. The obsessive belief that the highest ideals cannot be embraced by the lowest forms. An extremely difficult position, where even the highest ideals provide rationalization for hatred.

3 - Pessimism. The belief that what is best can never be achieved. The earth exalted. A lack of trust that can only be transformed through concrete evidence. Venus in detriment. Pessimism exalted to an art form, where as art, it may have the opposite effect. Satire.

4 - Fatigue. The point of exhaustion eventually reached when one is too tired to fight. Pluto exalted. The renaissance that comes with truce and its eventual reinvigoration. Venus in detriment. Emotional exhaustion. Appeasement and withdrawal.

5 - The Saviour. The ability to overcome all obstacles for the betterment of humanity. Neptune exalted. The charismatic genius who can find a role for everyone. Jupiter in detriment. The able administrator. Given the extreme positive nature of this position, mundane application is rare.

6 - The Optimist. The ability to accept any limited interaction as a necessary step towards greater union. Mars exalted. The energy to persevere. Unlimited hope. Mercury in detriment. Naivete. The translation of mutual interest into universality.

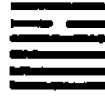

Possession in Great Measure

24°30'00'' \uparrow - 00°07'30'' \nearrow

The Lines

1-24°30'00'' - 25°26'15''
 2-25°26'15'' - 26°22'30''
 3-26°22'30'' - 27°18'45''
 4-27°18'45'' - 28°15'00''
 5-28°15'00'' - 29°11'15''
 6-29°11'15'' - 00°07'30''

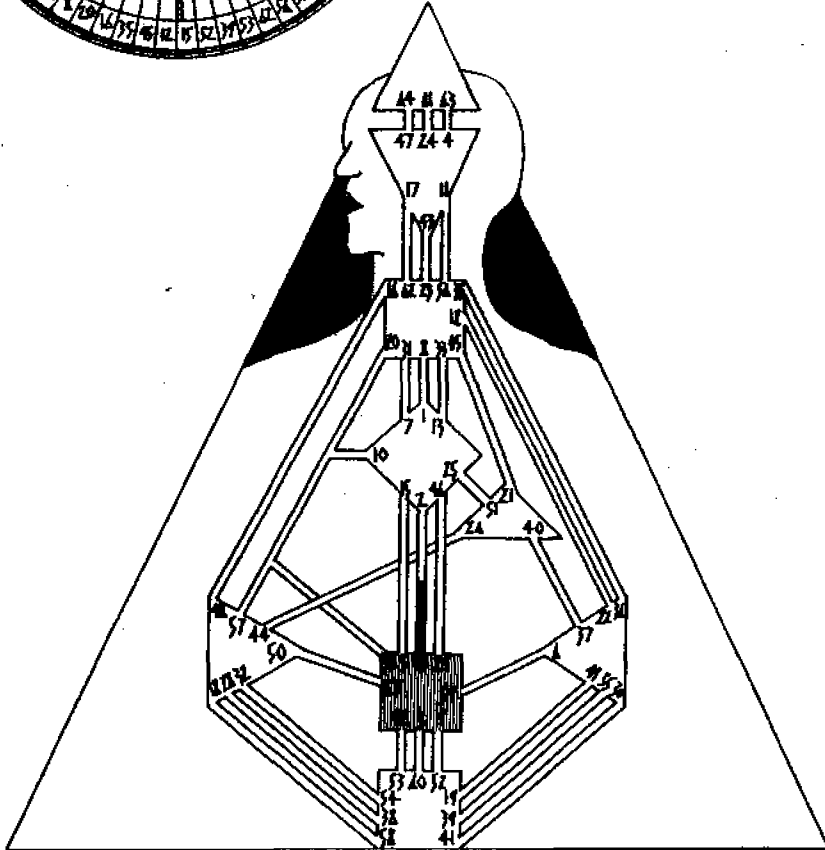
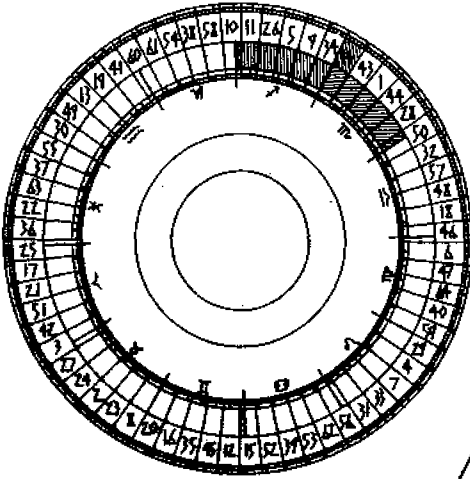

Possession in Great Measure

Sign (Cusp Hexagram): Scorpio-Fixed. Transcendence Sex Death
Regeneration
Sagittarius-Mutable. Philosophy Religion Idealism

Center: Sacral. Maturation Reproduction Sexuality

Biology: The Ovaries and Testes

Gate: 14 Possession in Great Measure

Harmonic Gate: 2 The Receptive

Channel: 14-2 The Beat. The design of being the keeper of
keys

The accumulation and retention of power through skilled
interaction, coupling grace with control.

The Lines

1 - Money isn't everything. The recognition that wealth has
its own problems. Jupiter exalted. The lust for lucre tem-
pered by higher principles. Mercury in detriment. The de-
lusion that you can throw money at problems.

2 - Management. The wisdom that investing in expertise
brings rewards. Jupiter exalted. Expansion. The ability to
delegate responsibility. Mars in detriment. The vanity to be
one's own best expert.

3 - Service. The utilization of talent and wealth for the
highest good. The Earth exalted. Selfless contribution to
society. Neptune in detriment. Greed and the self-destruction
of moral fibre.

4 - Security. The concentration on establishing a strong
foundation. The Moon exalted. Protection from assault. Mars
in detriment. Overconfidence in meeting the challenge of
competition that may threaten the very basis of security.

5 - Arrogance. The ever present risk inherent in positions
of power. The Sun exalted. Innate dignity. Venus in detri-
ment. A dissatisfaction with the gifts of others that
creates feelings of superiority.

6 - Humility. Wealth and power at its most exalted. The Sun
exalted. The enlightened recognition that material success
is God's will. The Earth in detriment. All manifestations of
this position are essentially positive. The Earth represents
the existentialist recognition that material success was
unavoidable and the humility engendered by such serendipity.

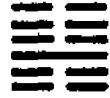
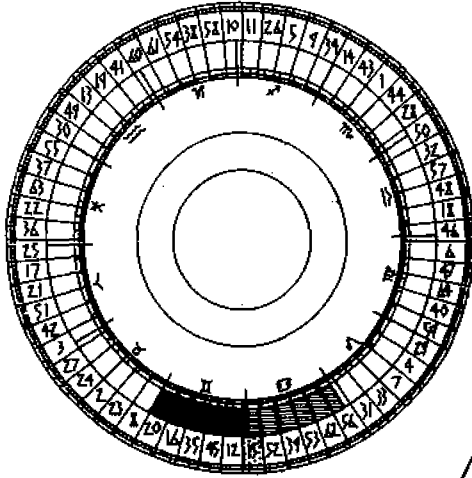

Modesty

28°15'00'' II - 03°52'30'' ☵

The Lines

- 1-28°15'00'' - 29°11'15''
- 2-29°11'15'' - 00°07'30''
- 3-00°07'30'' - 01°03'45''
- 4-01°03'45'' - 02°00'00''
- 5-02°00'00'' - 02°56'15''
- 6-02°56'15'' - 03°52'30''

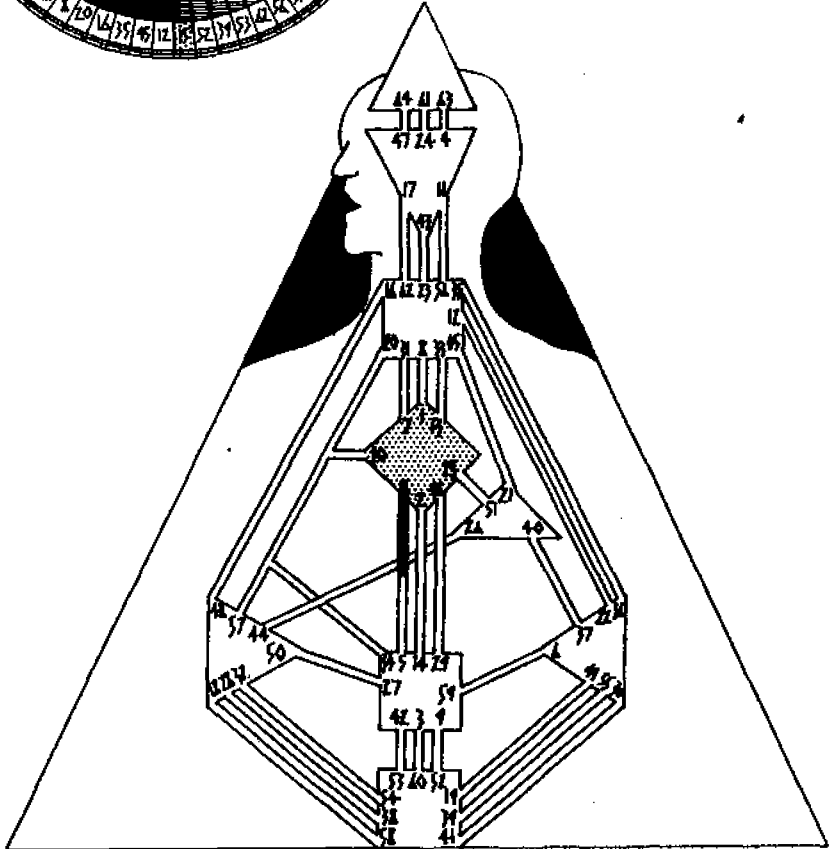

Modesty

Sign (Cusp Hexagram): Gemini-Mutable. Changeability Duality
Expansion
Cancer-Cardinal. Receptivity Sensitivity
Home Family

Center: G Center. Spirituality Gravity Attraction Love

Biology: The Liver

Gate: 15 Modesty

Harmonic Gate: 5 Waiting

Channel: 15-5 Rhythm. The design of being in the flow

The quality of behaviour which expresses the proper balance between extremes.

The Lines

1 - Duty. The ability to confront any challenge without expectations. Venus exalted. Harmonic relationships which give support for the fulfillment of any task. Mars in detriment. Alienation engendered through exaggerated claims.

2 - Influence. The Sun exalted. Modesty and right action result in enduring standards. The Earth in detriment. Where the Sun's actions are natural, the Earth's are contrived, though given the power of this position, the same effect can be expected.

3 - Ego inflation. The risk that modesty once recognized will self-destruct. The Earth exalted. Where the otherwise negative contrived modesty is here reinforced by recognition and maintained as an effective strategy. Mercury in detriment. The 'I told you so' mentality.

4 - The Wallflower. Modesty as a shield against exposure of inadequacy. Jupiter exalted. A genuine form that may/or may not mask inadequacies. Saturn in detriment. An ultimately weak defense leading to exposure and humiliation.

5 - Sensitivity. The ability to sense when otherwise balanced behaviour must be adjusted to meet the requirements of changing environment. Jupiter exalted. The power to grow. Pluto in detriment. The tendency to overcompensate.

6 - Self-defense. Modesty that is never confused with weakness. Pluto exalted. Constant reexamination to weed out the weakest aspect. Venus in detriment. A tendency to use harmony as a weapon in problem situations rather than focusing on the root causes.

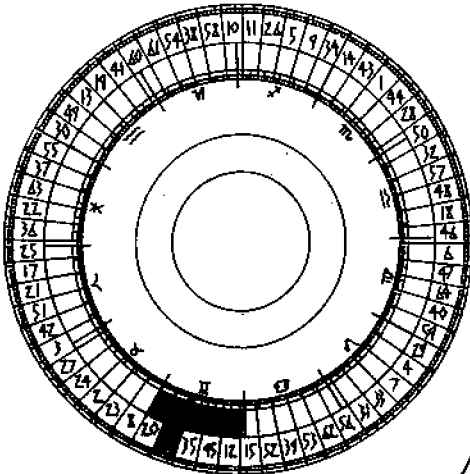

Enthusiasm

05°45'00'' - 11°22'30'' ☵

The Lines

- 1-05°45'00'' - 06°41'15''
- 2-06°41'15'' - 07°37'30''
- 3-07°37'30'' - 08°33'45''
- 4-08°33'45'' - 09°30'00''
- 5-09°30'00'' - 10°26'15''
- 6-10°26'15'' - 11°22'30''

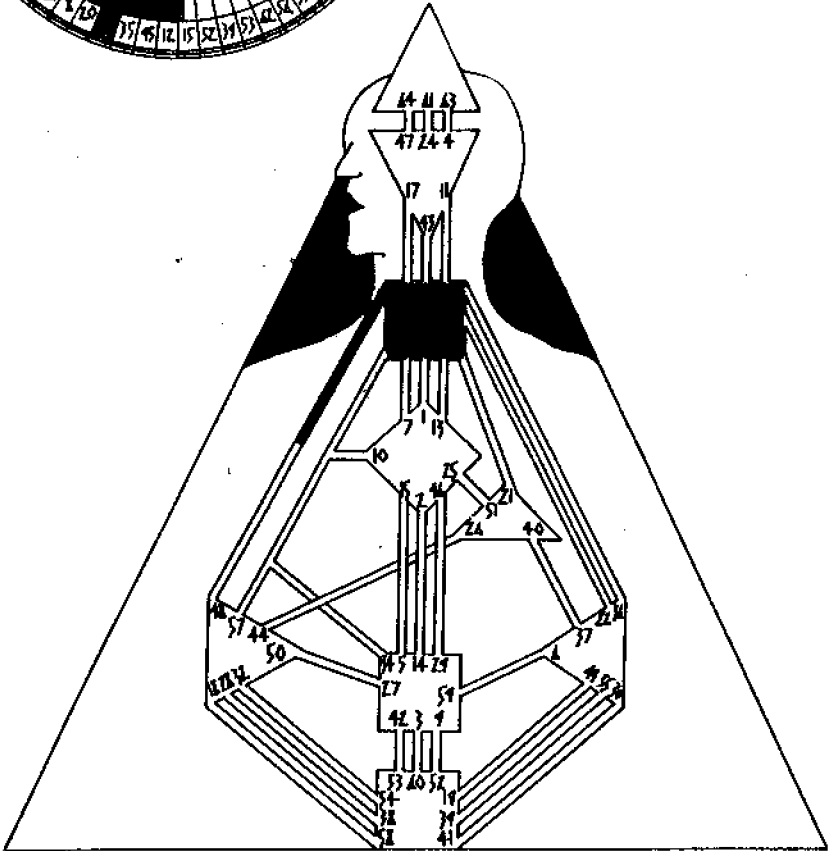

Enthusiasm

Sign: Gemini-Mutable. Changeability Duality Expansion

Center: Throat. Action Metamorphosis Unfolding

Biology: The Thyroid and Parathyroid Glands

Gate: 16 Enthusiasm

Harmonic Gate: 48 The Well

Channel: 16-48 The Wave Length. A design of talent

The great art of enriching life by the harmonic channelling of energy.

The Lines

1 - Delusion. False enthusiasm. The Earth exalted. The day dreamer. Mercury in detriment. The public communication of inevitably unrealized claims.

2 - The Cynic. The sharpness to burst bubbles. The Sun exalted. Self-reliance and the skill to judge objectively any claim regardless of rhetoric. Mercury in detriment. The compulsive cynic, whose very cynicism is a source of enthusiasm.

3 - Independence. Self-generating and sustaining enthusiasm. The Moon exalted. The proper timing to maintain rhythm and avoid deflation. Mars in detriment. The child whose overconfidence may lead to frustration and the ensuing dependence on others to regenerate enthusiasm; thus creating an unnecessary reliance.

4 - The leader. Genuine and sincere support and recognition of others. Jupiter exalted. Enthusiasm for/and service to higher goals. Mars in detriment. The demagogue.

5 - The grinch. The refusal to share in enthusiasm. Pluto exalted. The power to avoid enthusiasm for the sole purpose of being converted. As with Dickens' Scrooge, eventual conversion leads to greater and more enduring enthusiasm. The Moon in detriment. The perverse feeling that sharing in enthusiasm hampers individual development. Why should I be happy when ... etc.

6 - Gullibility. The susceptibility to propaganda. Neptune exalted. The ability to experience, examine and then reject misleading enthusiasm. Jupiter in detriment. The same principle but where Neptune will destroy and then seek new forms, Jupiter will painfully withdraw. Its enthusiasm for social structures permanently prejudiced.



Following

03°52'30'' - 09°30'00'' Y

The Lines

- 1-03°52'30'' - 04°48'45''
- 2-04°48'45'' - 05°45'00''
- 3-05°45'00'' - 06°41'15''
- 4-06°41'15'' - 07°37'30''
- 5-07°37'30'' - 08°33'45''
- 6-08°33'45'' - 09°30'00''

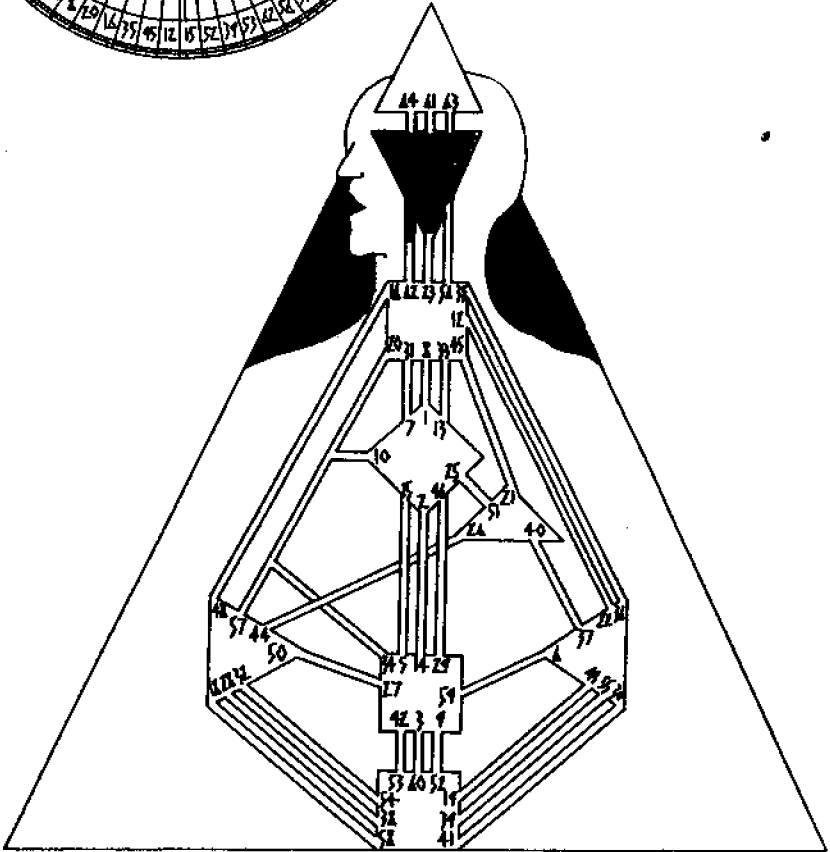
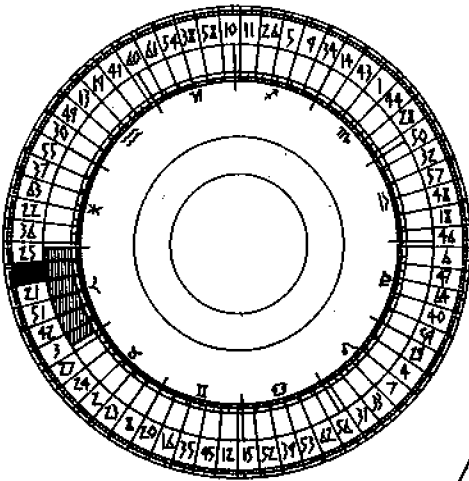

Following

Sign: Aries-Cardinal. Desire Will Impulse Courage

Center: Ajna. Knowing Intuition Understanding

Biology: The Anterior and Posterior Pituitary Glands

Gate: 17 Following

Harmonic Gate: 62 Preponderance of the Small

Channel: 17-62 Acceptance. A design of an organizational being

The ancient law that those who wish to rule must know how to serve.

The Lines

1 - Openness. Mars exalted. The energy to sustain a broad spectrum of stimuli. Venus in detriment. A tendency to limit openness to aesthetically pleasing stimuli.

2 - Discrimination. The benefit of associations based on the highest values. The Sun exalted. The successful achievement of purpose through proper alignment. The Moon in detriment. An overactive discrimination that leaves one virtually alone.

3 - Understanding. The awareness that the best road is not necessarily the most interesting. Pluto exalted. The following of the best road provides the experience necessary to meet the challenge of the road's end. The Earth in detriment. The taking of short cuts. One may get to the end quicker, but essential experience will be missing.

4 - The personnel manager. Pluto exalted. The ability to probe and discover the underlying motivation and resources of those who wish to follow. Jupiter in detriment. The overgenerous and often misguided acceptance of would-be followers, often with disastrous results.

5 - No man is an island. The recognition, however understood that there is no end to hierarchies. Uranus exalted. The ultimate creative expression of interdependency, whether as God's will or global synthesis. Mars in detriment. The arrogance, despite all the evidence to claim, that the buck stops here!

6 - The Bodhisattva. Perfected following, one with and the same as, perfected leading. The Moon exalted. The great nurturer. The nature of this position is always positive. Jupiter in detriment. The tendency on the perfected path it is a straight line that ends rather than a circle.

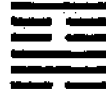
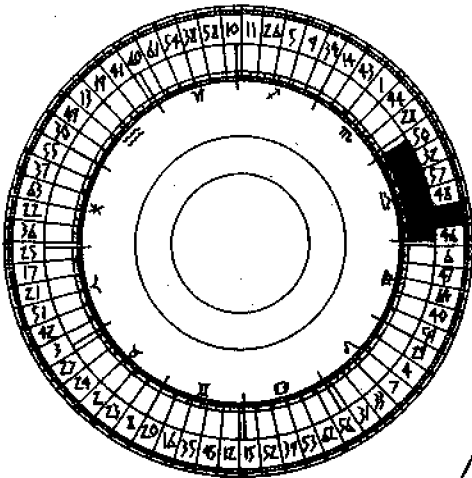

Work on What Has Been Spoilt

03°52'30'' - 09°30'00'' ☰

The Lines

- 1-03°52'30'' - 04°48'45''
- 2-04°48'45'' - 05°45'00''
- 3-05°45'00'' - 06°41'15''
- 4-06°41'15'' - 07°37'30''
- 5-07°37'30'' - 08°33'45''
- 6-08°33'45'' - 09°30'00''

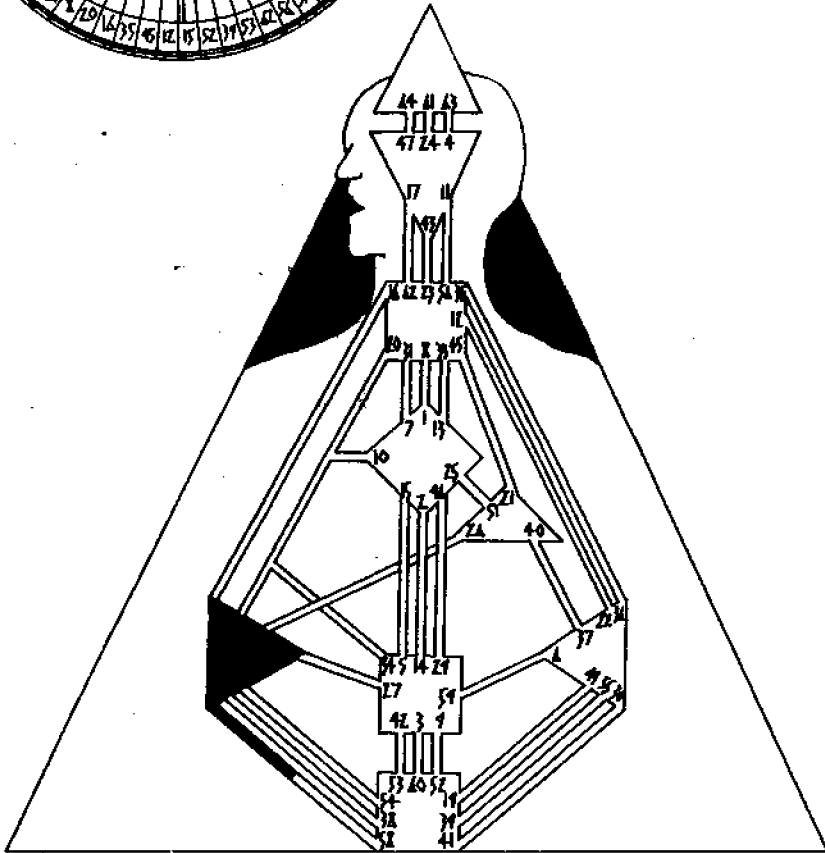

Work on What Has Been Spoilt

Sign: Libra-Cardinal. Comparison Appreciation Evaluation

Center: Splenic. Balance Judgment Cleansing

Biology: The Spleen and Lymph System

Gate: 18 Work on What Has Been Spoilt

Harmonic Gate: 58 The Joyous

Channel: 18-58 Judgment. A design of insatiability

The vigilance and determination to uphold and defend basic and fundamental human rights.

The Lines

1 - Conservatism. The adherence to traditional patterns despite and/or in spite of changing circumstances. The Earth exalted. Gradual modification to avoid eventual upheaval. Jupiter in detriment. The Patriarch whose rigidity guarantees deterioration.

2 - Terminal disease. The recognition that what has been spoilt is irreversible. Pluto exalted. Acceptance and strength derived from a faith in spiritual regeneration. The Moon in detriment. The futile raging against the wind.

3 - The zealot. The energetic obsession to clean house. Neptune exalted. The dissolution of old forms at an acceptable price. Jupiter in detriment. Rigid judgmentation that creates as many problems as it solves.

4 - The incompetent. Difficulties as a result of inadequacies that cannot be resolved because of inadequacies. The Earth exalted. Given this negative position, survival through suffering. Mercury in detriment. Indecision and anxiety and no escape from misfortune.

5 - Therapy. The strength to recognize a problem and to accept that it is beyond one's power to solve it alone. Saturn exalted. The wisdom to both seek and provide guidance. Uranus in detriment. The mental patient. Chronic instability and potential madness.

6 - Buddhahood. The perfected form. Mars exalted. The Buddha state of the eternal child and the energy to find new horizons to avoid stasis. The Moon in detriment. The mundane application of the above. The ability to tap public opinion and share methodology.

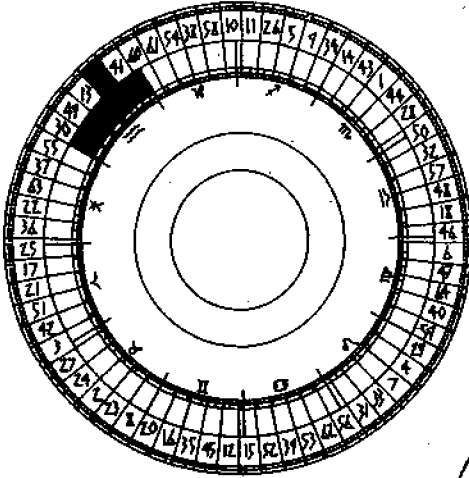

Approach

07°37'30" - 13°15'00" ☰

The Lines

- 1-07°37'30" - 08°33'45"
- 2-08°33'45" - 09°30'00"
- 3-09°30'00" - 10°26'15"
- 4-10°26'15" - 11°22'30"
- 5-11°22'30" - 12°18'45"
- 6-12°18'45" - 13°15'00"

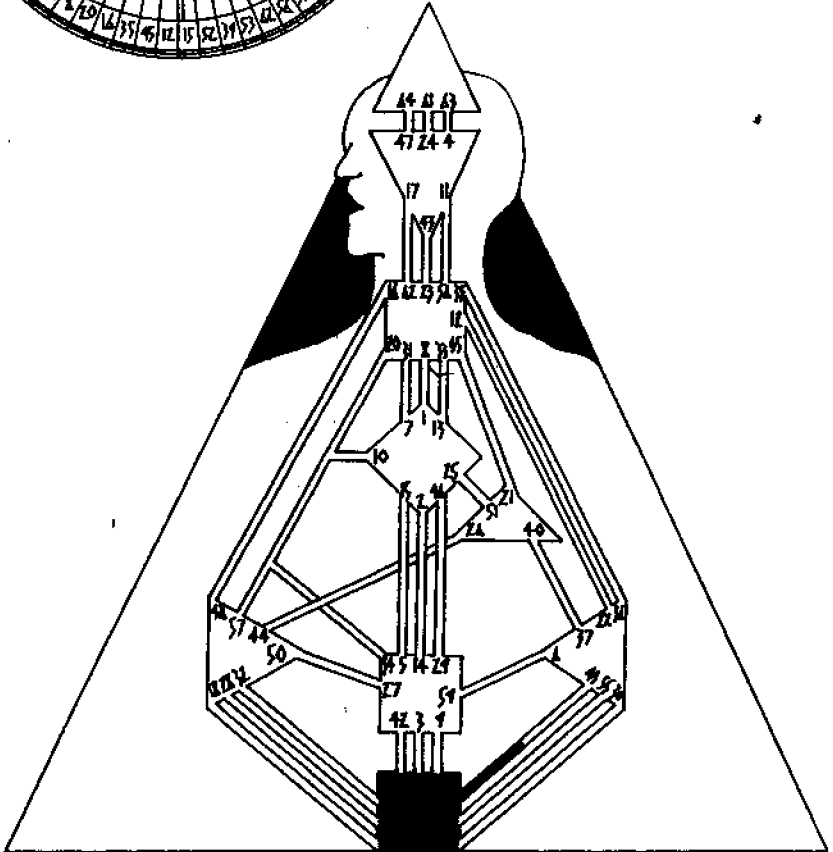

Approach

Sign: Aquarius-Fixed. Science Humanitarianism Music

Center: The Base of the Spine. Assertion Energy Evolution

Biology: The Adrenal Glands

Gate: 19 Approach

Harmonic Gate: 49 Revolution

Channel: 19-49 Synthesis. A design of being sensitive

That all things are interrelated is apparent and manifested through the action of approach.

The Lines

1 - Interdependence. The Sun exalted. The successful approach that does not lose its individual character in acceptance. The Moon in detriment. The tendency once an approach is accepted to get stuck in continued reflection at the expense of continued development.

2 - Service. The dedication of personal resources as a result of external contact. Jupiter exalted. Dedication and service to the highest values. Mercury in detriment. Protracted indecision, but given the nature of this position, eventual compliance.

3 - Dedication. Receptivity to approach can only be maintained through vigilance. Venus exalted. The natural ease with which communion is maintained. The Moon in detriment. A tendency to moodiness that may lead to carelessness.

4 - The team player. Individual approach which attracts and accepts cooperation. Mars exalted and at its best. The power and energy for outward activity and the ability to accept others as long as they can keep up. A driving force which can benefit the whole group. Venus in detriment. Attractive and cooperative but a tendency to dissatisfaction with the contribution of others.

5 - Sacrifice. The need to limit personal potential in order to achieve a larger goal. The Earth exalted. The self-restraint fundamental to such a nature. Jupiter in detriment. A tendency in sacrifice to condescend.

6 - The recluse. The avoidance of contact in general but not exclusively. Jupiter exalted. The fool on the hill. The sage, that if you can find him, will talk to you. Mars in detriment. The sulking child. The self-imposed exile that will only end when it attracts appropriate and soothing reaction.

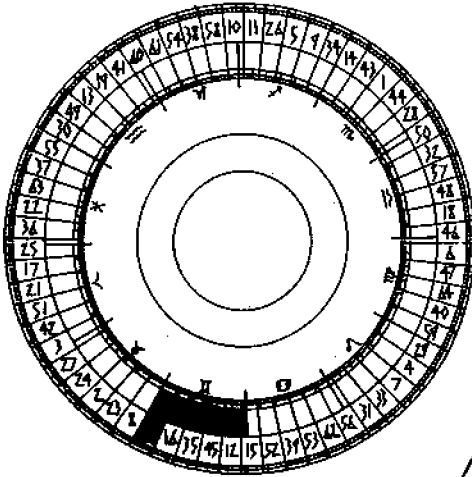

Contemplation

00°07'30'' - 05°45'00'' II

The Lines

- 1-00°07'30'' - 01°03'45''
- 2-01°03'45'' - 02°00'00''
- 3-02°00'00'' - 02°56'15''
- 4-02°56'15'' - 03°52'30''
- 5-03°52'30'' - 04°48'45''
- 6-04°48'45'' - 05°45'00''

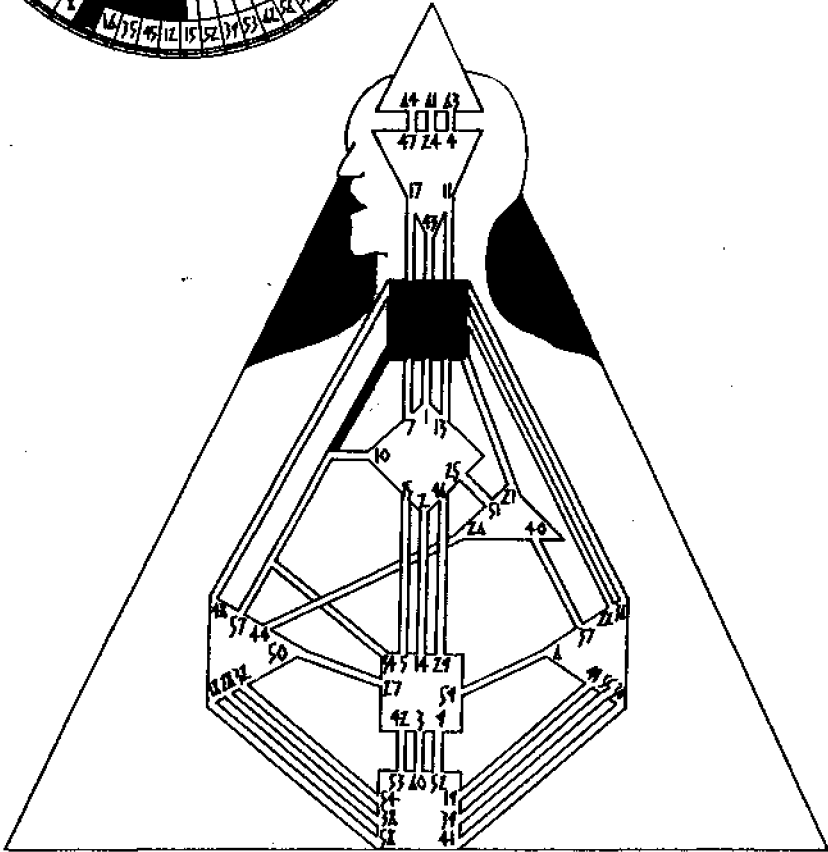

Contemplation

Sign: Gemini-Mutable. Changeability Duality Expansion

Center: Throat. Action Metamorphosis Unfolding

Biology: The Thyroid and Parathyroid Glands

Gate: 20 Contemplation **Harmonic Gates:** 10 Treading
34 The Power of the
Great
57 The Gentle

Channels:

20-10 Awakening. A design of commitment to higher principles

20-34 Charisma. A design where thoughts must become deeds

20-57 The Brain Wave. A design of awareness

Recognition and awareness in the now which transforms understanding into right action.

The Lines

1 - Superficiality. A reliance on shallowness. Venus exalted. The raising of superficiality to an art form. The sloganer. The Moon in detriment. The superficial expression of the personality.

2 - The dogmatist. Restrictive and intentionally limited understanding. Venus exalted. The limitation if personal and exclusive is less negative through ascetic withdrawal. The Moon in detriment. The power to lead others down a narrow path.

3 - Self-awareness. Understanding derived from analysis of personal actions and effects. The Sun exalted. The proper attunement and development of the personality through self-consciousness. The Earth in detriment. Self-consciousness in the extreme that hampers development.

4 - Application. Recognition and awareness that can only be transformed into action in cooperation with those who have the ability to act upon the understanding. Jupiter exalted. The teacher whose students transcend him. Mercury in detriment. A tendency to prefer theory to application.

5 - Realism. Contemplation, in and of itself, is no guarantee of success. Saturn exalted. Where concentration on detail results in a perfected form. Uranus in detriment. Where reality creates dissatisfaction and adds to instability.

6 - Wisdom. Contemplation which results in the ability to apply understanding. Venus exalted. The establishment for the benefit of society, values, ideals and their patterns and how they can be understood and applied. Mercury in detriment. The same as above but motivated by the self-satisfying mental challenge rather than altruism.



Biting Through

09°30'00'' - 15°07'30'' Y

The Lines

- 1-09°30'00'' - 10°26'15''
- 2-10°26'15'' - 11°22'30''
- 3-11°22'30'' - 12°18'45''
- 4-12°18'45'' - 13°15'00''
- 5-13°15'00'' - 14°11'15''
- 6-14°11'15'' - 15°07'30''

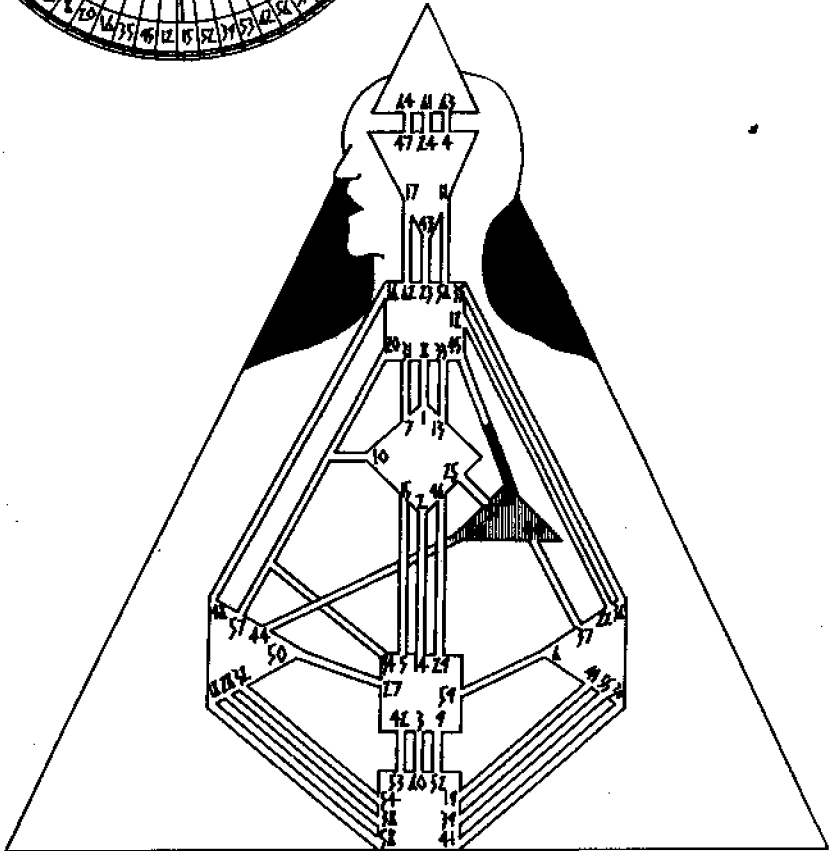
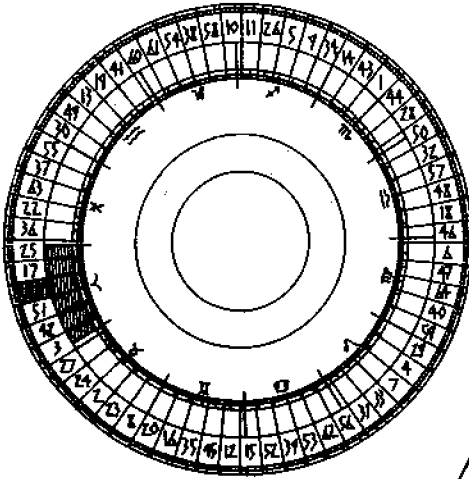

Biting Through

Sign: Aries-Cardinal. Desire Will Impulse Courage

Center: Heart. Ego Zeal Passion.

Biology: The Thymus Gland

Gate: 21 Biting Through

Harmonic Gate: 45 Gathering Together

Channel: 21-45 The Money Line. A design of a materialist

The justified and necessary use of power in overcoming deliberate and persistent interference.

The Lines

1 - Warning. The use of force as a last resort. Mars exalted. The fierceness to be respected without recourse to action. The Moon in detriment. An inherent peacefulness that all too often turns a necessary warning into a plea.

2 - Might is right. The legitimacy of action in response to flagrant and persistent interference. Mars exalted. Powerful and extreme reaction. Here, the severest action will be the most successful. Neptune in detriment. A tendency to regret severity, no matter how legitimate.

3 - Powerlessness. Where the just are condemned to a futile confrontation with superior forces. Neptune exalted. Defeat as a survivable humiliation often acceptable through the abuse of drugs and alcohol. Jupiter in detriment. Total withdrawal.

4 - Strategy. Careful appraisal of opposing forces to establish a proper response. Jupiter exalted. Success in action through clarity. The Earth in detriment. A tendency, when in the right to misjudge the power of one's opponents.

5 - Objectivity. The use of force must be based on impartiality and not emotionally motivated. Jupiter exalted. A principled and legal character that ensures objectivity. Pluto in detriment. The drive for elimination is so powerful that objectivity is related purely to cause and not effect.

6 - Chaos. Where ineffective action leads to disorder. Pluto exalted. The war of attrition. The continuance of legitimate action in the hope of eventually succeeding despite all odds and increasing disorder. Venus in detriment. Withdrawal and reliance on inner order in a chaotic situation.



Grace

17°00'00'' - 22°37'30'' ✕

The Lines

1-17°00'00''	- 17°56'15''
2-17°56'15''	- 18°52'30''
3-18°52'30''	- 19°48'45''
4-19°48'45''	- 20°45'00''
5-20°45'00''	- 21°41'15''
6-21°41'15''	- 22°37'30''

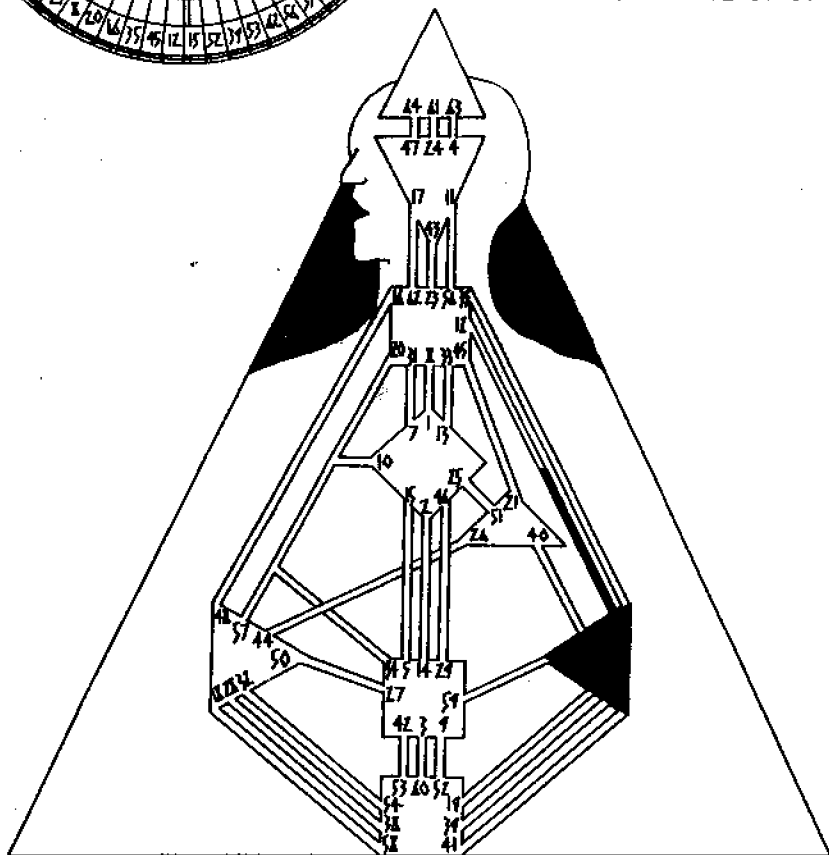
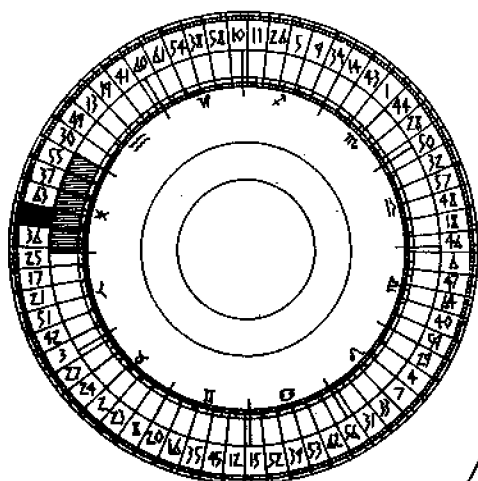

Grace

Sign: Pisces-Mutable. Openness Devotion Conflict

Center: Solar Plexus. Aspiration Sensitivity Emotion

Biology: The Kidney and Pancreas

Gate: 22 Grace

Harmonic Gate: 12 Standstill

Channel: 22-12 Openness. The design of the social being

A quality of behaviour best suited in handling mundane and trivial situations.

The Lines

1 - Second class ticket. The Moon exalted. The ability to accept and enjoy a subordinate position. Mars in detriment. The inevitable humiliation that comes with claiming a first class seat with a second class ticket.

2 - Charm school. The belief that style can mask nature. The Sun exalted. The ability to successfully delude oneself and others. Jupiter in detriment. The legalization of form over substance.

3 - The enchanter. Perfected grace. Saturn exalted. Form as a definition and actualization of substance. Mars in detriment. Unconscious grace.

4 - Sensitivity. The modification of behaviour to enrich interactions. Neptune exalted. A mediumistic simplicity that rejects elaborate rituals. Mars in detriment. An over-reliance on the mechanics of style that can abort potentially significant relationships.

5 - Directness. The disregard of form when required. Jupiter exalted. The power inherent in higher principles to successfully transgress behavioral codes. Mars in detriment. A tendency to create embarrassing situations, and though invariably successful, the often resulting reputation for crudity and impudence.

6 - Maturity. The alignment with experience of form with substance. The Sun exalted. Natural and evident leadership and authority. Mars in detriment. The alignment tends to express itself in non-conformist modes.

Splitting Apart

Sign: Taurus-Fixed. Materialism Practicality Inertia

Center: Throat. Action Metamorphosis Unfolding

Biology: The Thyroid and Parathyroid Glands

Gate: 23 Splitting Apart

Harmonic Gate: 43 Breakthrough

Channel: 23-43 Structuring. A design of individuality
(Genius to Freak)

Amorality. The awareness and understanding which leads to the acceptance of diversity.

The Lines

1 - Proselytization. The attempt to undermine one set of values for another. Jupiter exalted. The sage, who in the extreme can defend evil as a part of the greater good. Mars in detriment. The missionary whose very light will bring darkness.

2 - Self-defense. The need to abandon tolerance when survival is threatened. Jupiter exalted. The principle of preservation at its most acute. The Moon in detriment. Where Jupiter will strike out to preserve its integrity, the Moon is often satisfied with just protecting itself by fending of hostility.

3 - Individuality. Independent expression that is not by its nature detrimental to others. The Sun exalted. Vitality and personal power that can engender jealousy but not threat. Pluto in detriment. An individual mysteriousness that attracts active suspicion and threat.

4 - Fragmentation. Diversification without a perceived potential for synthesis. The Sun exalted. Fatalism and egoism and damn the consequences. The Earth in detriment. Atheism and paranoia.

5 - Assimilation. The practical acceptance of the values of another path. Jupiter exalted. Expansion and contribution through assimilation. The Moon in detriment. Motive driven assimilation from an inferior position, i.e. for protection or nourishment.

6 - Fusion. The gradual attainment of diversity through synthesis. Mars exalted. The exponential growth of energy and its power of assertion engendered by fusion. Jupiter in detriment. The principled but futile withdrawal from fusion that leads to atrophy.

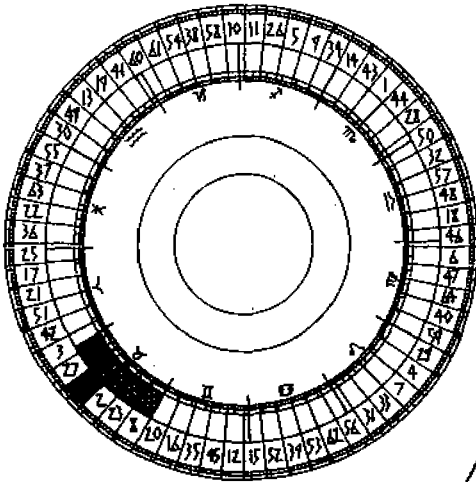

Returning

07°37'30" - 13°15'00" ☷

The Lines

- 1-07°37'30" - 08°33'45"
- 2-08°33'45" - 09°30'00"
- 3-09°30'00" - 10°26'15"
- 4-10°26'15" - 11°22'30"
- 5-11°22'30" - 12°18'45"
- 6-12°18'45" - 13°15'00"

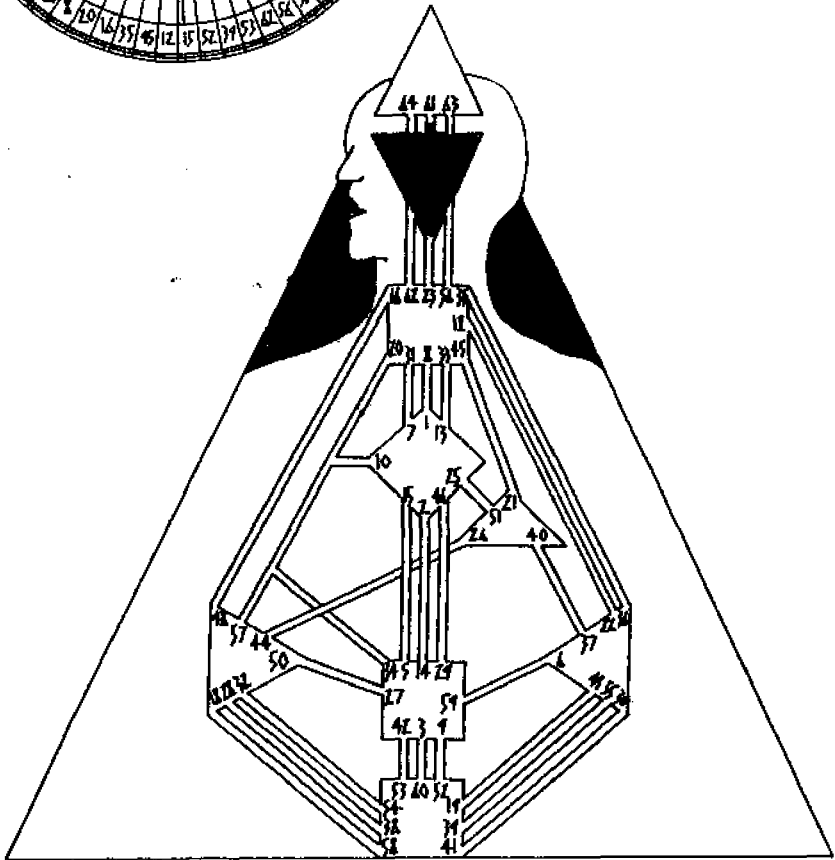

Returning

Sign: Taurus-Fixed. Materialism Practicality Inertia

Center: Ajna. Knowing Intuition Understanding

Biology: The Anterior and Posterior Pituitary Glands

Gate: 24 Returning

Harmonic Gate: 61 Inner Truth

Channel: 24-61 Awareness. A design of the thinker

The natural and spontaneous process of transformation and renewal.

The Lines

1 - The sin of omission. Transformation that requires retrogressive periods before renewal can take place. The Sun exalted. The will to triumph and in this case the faith that the end justifies the means. Neptune in detriment. Self-delusion which unnaturally justifies periods of retrogression.

2 - Recognition. The Moon exalted. The proper and spontaneous adaption to new forms. Mars in detriment. The vanity to see transformation as a personal achievement rather than a socially supported or natural phenomenon.

3 - The addict. The powerful attraction of regressive forms. Venus exalted. The ultimate though difficult triumph over regression. Jupiter in detriment. Addiction and regression legitimized by success.

4 - The hermit. Transformation that can only take place in isolation. Saturn exalted. The discipline and focus that assures renewal. Neptune in detriment. The tendency in isolation to live in a fantasy world.

5 - Confession. The courage to admit the mistakes of the past. The Moon exalted. The practical value of starting with a clean slate, symbolized by the New Moon. Mars in detriment. The tendency to try to minimize past mistakes through rationalization; turning confession into justification.

6 - The gift horse. The possibility of being deaf when opportunity knocks. Jupiter exalted. The conscious participation in a process that prepares one for easy identification of opportunity. Pluto in detriment. Innate suspicion which leads inevitably to lost opportunities.

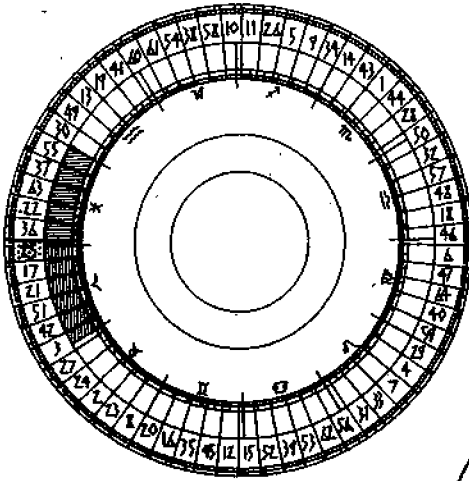

Innocence

28°15'00'' ♀ - 03°52'30'' ♀

The Lines

- 1-28°15'00'' - 29°11'15''
- 2-29°11'15'' - 00°07'30''
- 3-00°07'30'' - 01°03'45''
- 4-01°03'45'' - 02°00'00''
- 5-02°00'00'' - 02°56'15''
- 6-02°56'15'' - 03°52'30''

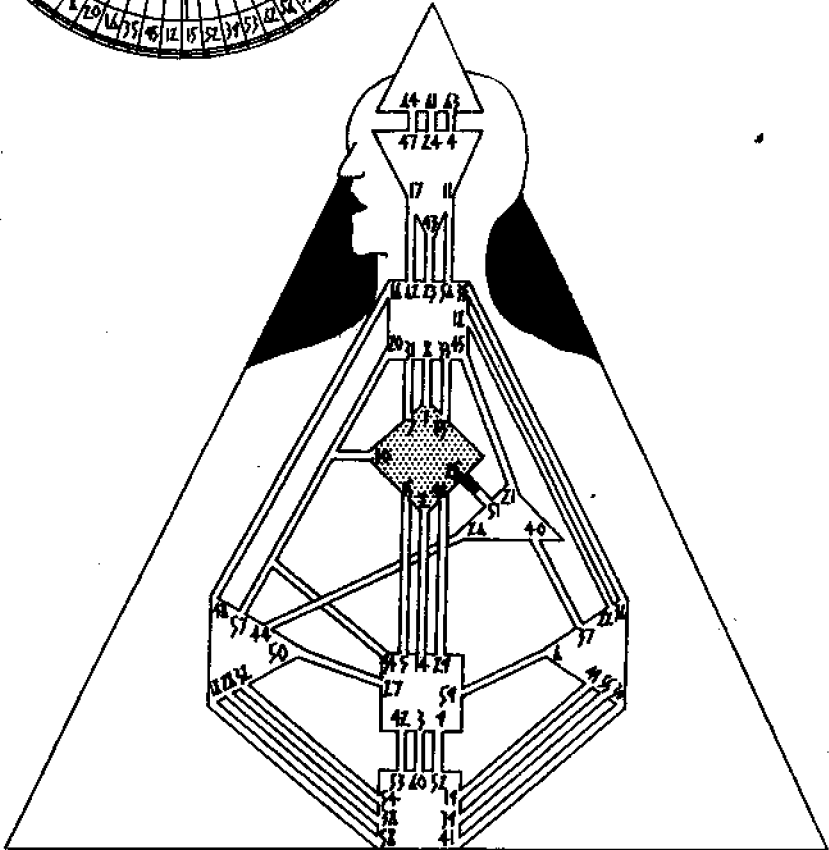

Innocence

Sign (Cusp Hexagram): Pisces-Mutable. Openness Devotion
Conflict
Aries-Cardinal. Desire Will Impulse Courage

Center: G Center. Spirituality Gravity Attraction Love

Biology: The Liver

Gate: 25 Innocence

Harmonic Gate: 51 The Arousing

Channel: 25-51 Initiation. A design of needing to be first

The perfection of action through uncontrived and spontaneous nature.

The Lines

1 - Selflessness. Motiveless action. Neptune exalted. The universalization of activity. Psychic attunement that is its own reward. Mercury in detriment. A tendency to publicize one's selflessness.

2 - The existentialist. Devotion and dedication to the now. Mercury exalted. The perfection of the intellect through concentration and focus on what is, rather than, what could be or has been. Mars in detriment. A dedication that can never be free of personal motivation and its attendant projections.

3 - Sensibility. The recognition that innocent action does not in itself guarantee success. Mars exalted. The power of the ego to withstand failure and still maintain its nature. Pluto in detriment. The potential loss of innocence through misfortune that in the extreme can manifest from crime to suicide.

4 - Survival. The nature of true innocence can be maintained regardless of circumstances. Venus exalted. The beauty of the rose in the garbage dump. Jupiter is also exalted. The highest principles even amongst the greatest decadence. There is no planet in detriment.

5 - Recuperation. When innocence is sapped of its vitality, healing is the first priority. Venus exalted. The ability to recognize the inner meaning of an affliction and to withdraw until it is healed. Jupiter in detriment. Hypochondria and the need to be healed by others.

6 - Ignorance. False innocence betrayed by actions. The Earth exalted. The least mild of a negative position, where inappropriate action is censured. Uranus in detriment. Constant inappropriate and destabilizing actions whose very counter-productiveness strips away the facade of innocence.



The Taming Power of the Great

17°00'00'' - 22°37'30'' ↗

The Lines

- 1-17°00'00'' - 17°56'15''
- 2-17°56'15'' - 18°52'30''
- 3-18°52'30'' - 19°48'45''
- 4-19°48'45'' - 20°45'00''
- 5-20°45'00'' - 21°41'15''
- 6-21°41'15'' - 22°37'30''

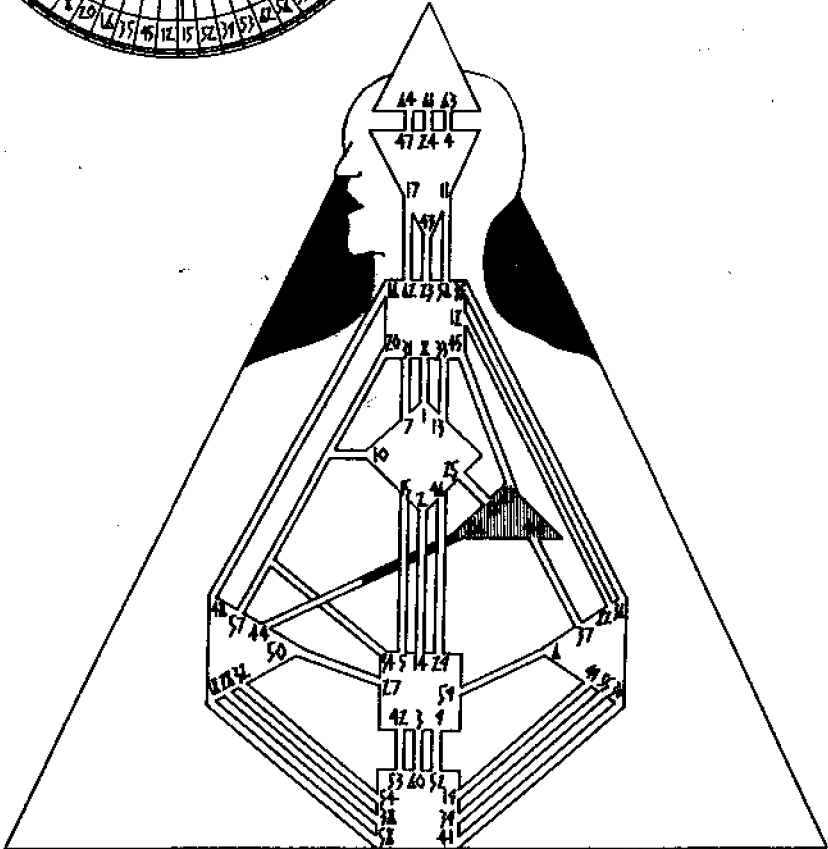
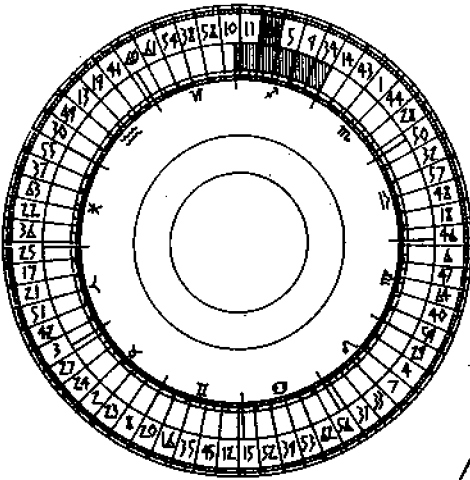

The Taming Power of the Great

Sign: Sagittarius-Mutable. Philosophy Religion Idealism

Center: Heart. Ego Zeal Passion

Biology: The Thymus Gland

Gate: 26 The Taming Power of the Great

Harmonic Gate: Coming to Meet

Channel: 26-44 Surrender. A design of a transmitter

The maximization of the power of memory applied to the nurturing of continuity.

The Lines

1 - A bird in the hand. Neptune exalted. The ability to enjoy the dreams engendered by accomplishment in order to avoid the delusion of unlikely potential. Mars in detriment. Accomplishment as a licence for foolhardy risk taking.

2 - The lessons of history. The Sun exalted. The energy and depth of reflection to learn from the past in anticipation of the future. Pluto in detriment. The urge to take action despite the evidence of history.

3 - Influence. The ability, once prepared to gather support. The Sun exalted. The authority to focus communal effort. Saturn in detriment. The leadership, while gathering support will underestimate potential challenges.

4 - Censorship. The alteration of memory through elimination. Pluto exalted. The ability through censorship to save the collectivity from itself. Saturn in detriment. The use of censorship to maintain the status quo; selective memory in fear of unrestrained consequences.

5 - Adaptability. Mars exalted. The understanding of mechanics and the application of energy to achieve maximum potential. Venus in detriment. A resistance and dissatisfaction when basic changes to nature are necessary.

6 - Authority. The natural attainment of influence justified by the correctness of actions. The Sun exalted. The embodiment of reason and purpose that passes the test of time. The Moon in detriment attains authority as a symbol and focus but not necessarily as a true embodiment. The constitutional monarch, stripped of real power but still the symbol of the continuity of authority.

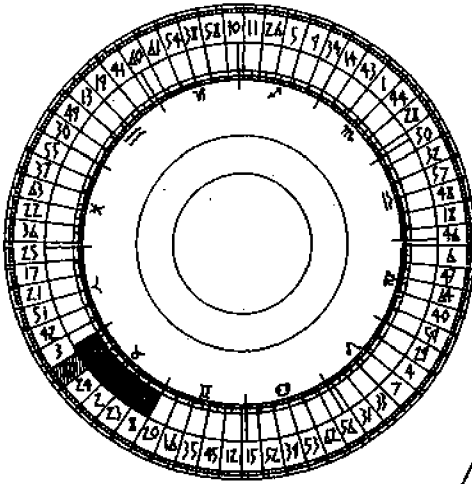

Nourishment

02°00'00'' - 07°37'30'' ☱

The Lines

- 1-02°00'00'' - 02°56'15''
- 2-02°56'15'' - 03°52'30''
- 3-03°52'30'' - 04°48'45''
- 4-04°48'45'' - 05°45'00''
- 5-05°45'00'' - 06°41'15''
- 6-06°41'15'' - 07°37'30''

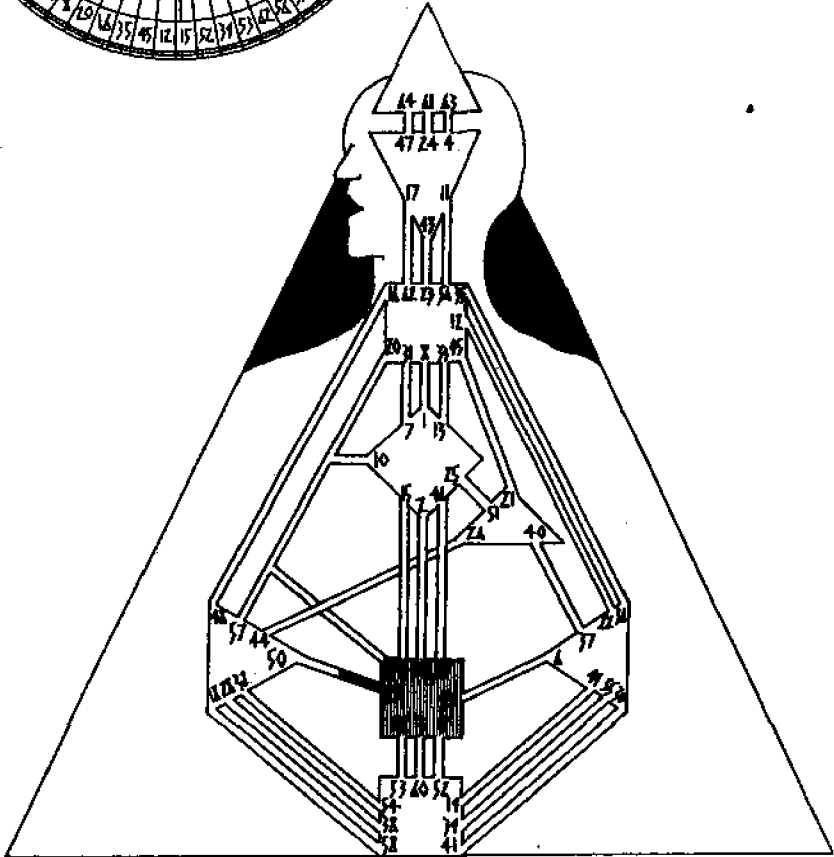

Nourishment

Sign: Taurus-Fixed. Materialism Practicality Inertia

Center: Sacral. Maturation Reproduction Sexuality

Biology: The Ovaries and the Testes

Gate: 27 Nourishment

Harmonic Gate: 50 The Cauldron

Channel: 27-50 Preservation. A design of custodianship

The enhancement of the quality and the substance of all activities through caring.

The Lines

1 - Selfishness. The Sun exalted. The ego-driven first law of caring for oneself which is not necessarily at the expense of others. The Earth in detriment. Envy and its attendant misfortunes.

2 - Self-sufficiency. The obvious law that to give, one must have. The Moon exalted. The Mother. The great nourisher. Mars in detriment. The child depleting the resources of others.

3 - Greed. The obsession with having much more than one needs. Pluto exalted. Here, the psychological manifestation. The obsession and dependency on knowing what is hidden. The secret policeman. Mars in detriment. Mundane and wholly without redeeming value, greed, a lust that inevitably cripples and addicts.

4 - Generosity. The natural sharing of attained abundance. Jupiter exalted. Magnanimous and qualitative sharing. The gift of rewarding those who are deserving. Mars in detriment. Indiscriminate sharing.

5 - The executor. The ability to distribute effectively the resources of others. Jupiter exalted. Either, the gifted and principled agent of distribution or the good sense and ability to find one. Saturn in detriment. A restrictive nature that hampers distribution or the seeking of advice and assistance.

6 - Wariness. A protection against an abuse of generosity. The Moon exalted. A practical and realistic approach to nurturing, whose appropriateness is guided by feelings and instinct. Pluto in detriment. A tendency to over-suspiciousness.

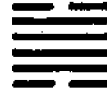
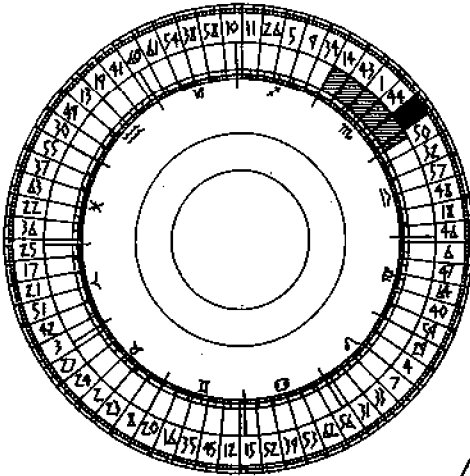

Preponderance of the Great

02°00'00'' - 07°37'30'' 11L

The Lines

- 1-02°00'00'' - 02°56'15''
- 2-02°56'15'' - 03°52'30''
- 3-03°52'30'' - 04°48'45''
- 4-04°48'45'' - 05°45'00''
- 5-05°45'00'' - 06°41'15''
- 6-06°41'15'' - 07°37'30''

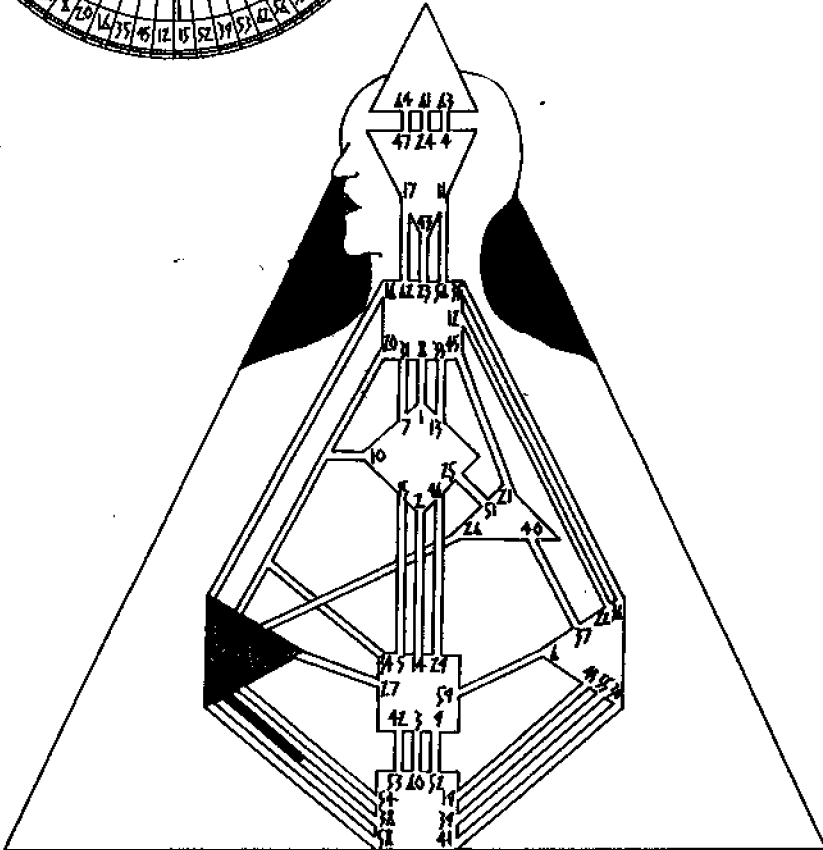

Preponderance of the Great

Sign: Scorpio-Fixed. Transcendence Sex Death Regeneration

Center: Splenic. Balance Judgment Cleansing

Biology: The Spleen and Lymph System

Gate: 28 Preponderance of the Great

Harmonic Gate: 38 Opposition

Channel: 28-38 Struggle. A design of stubbornness

The transitoriness of power and influence.

The Lines

1 - Preparation. Mars exalted. The desire to be effective manifested in the application of energy to detail. Venus in detriment. The aesthetic appreciation of planning that may have no real application.

2 - Shaking hands with the Devil. Distasteful alliance. The Sun exalted. A means, however unsavoury, that is justified by its end. Jupiter in detriment. The anxiety engendered by sacrificing higher principles when there is no guarantee of success.

3 - Adventurism. Unfounded risk taking. Saturn exalted. A basic conservatism that even in adventurous acts is necessarily prudent. Jupiter in detriment. Here a perverse manifestation of Jupiter's expansiveness where risk taking is rationalized and failure ensured.

4 - Holding on. The ability through whatever means to keep one's grip. Jupiter exalted. The application of knowledge to exploit opportunities and usually for the greater good. Mercury in detriment. The application of intelligence to hold on, exclusively out of self-interest.

5 - Treachery. The abuse of trust. Pluto exalted. The manipulation of the collective, that while pitting one faction against the other, does not directly support or reject either. The Sun in detriment. The breaking of alliances with trusted forces to align with more powerful forces and its attendant destabilization of the whole.

6 - Blaze of glory. Sacrifice rather than capitulation to the law of deterioration. Pluto exalted. Regeneration and renewal no matter what the price. Neptune in detriment. Self-destruction.

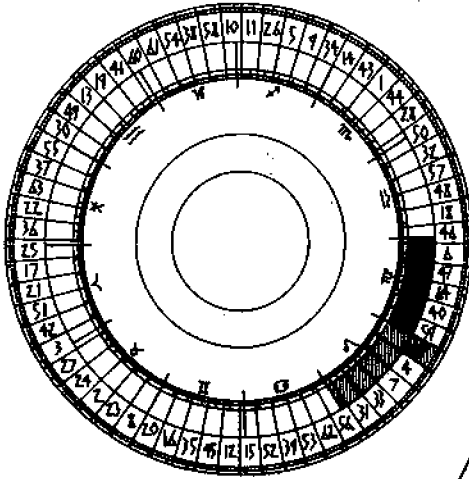

The Abyamal

24°30'00'' δ - 00°07'30'' π

The Lines

- 1-24°30'00'' - 25°26'15''
- 2-25°26'15'' - 26°22'30''
- 3-26°22'30'' - 27°18'45''
- 4-27°18'45'' - 28°15'00''
- 5-28°15'00'' - 29°11'15''
- 6-29°11'15'' - 00°07'30''

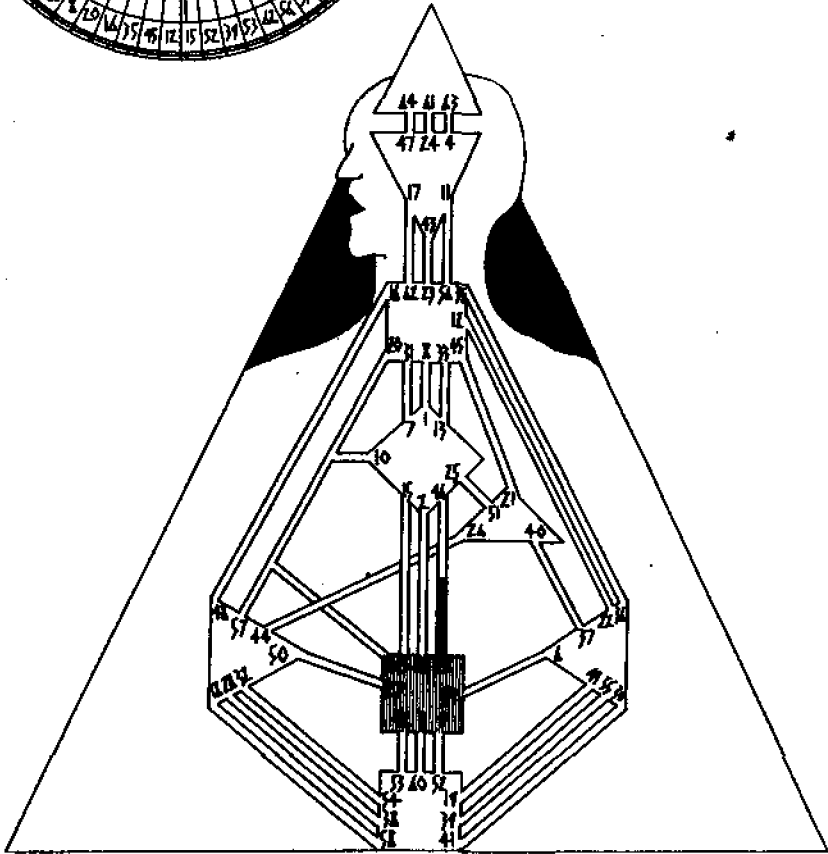

The Abyssal

Sign (Cusp Hexagram): Leo-Fixed. Self-expression Pleasure
Authority
Virgo-Mutable. Mental detail Service Judgmentation

Center: Sacral. Maturation Reproduction Sexuality

Biology: The Ovaries and the Testes

Gate: 29 The Abyssal

Harmonic Gate: 46 Pushing Upward

Channel: 29-46 Discovery. A design of succeeding where
others fail

The deep within the deep. Persistence despite difficulties has its inevitable rewards.

The Lines

- 1 - The draftee. The ability to adapt to struggle when necessary but not as a permanent state. Mars exalted. The innate nature to apply energy in times of war and peace. Neptune in detriment. A deep impressionability whose mark from times of struggle may make a return to normal conditions extremely difficult.
- 2 - Assessment. Persistence tempered by caution. The Sun exalted. The power of sustainment as a guiding light. Venus in detriment. A tendency to overcautiousness when persistence is perceived as adding to rather than ending disharmony.
- 3 - Evaluation. In this context, properly assessed inaction. Mars exalted. Despite the urge and cost of inaction the knowledge that it is sometimes better to fight another day. Jupiter in detriment. A preference for withdrawal in principle with little regard for effect.
- 4 - Directness. The shortest distance between two points is a straight line. Saturn exalted. The wisdom to use the simplest and most direct approach to solve difficulties. Venus in detriment. Simplicity and directness all too often seen as inharmonic and aesthetically crude.
- 5 - Overreach. The tendency to bite off more than one can chew. The Sun exalted, where the drive is in the design and not ambition driven. The Earth in detriment. Failed ambition.
- 6 - Confusion. The state that exists when momentum outstrips awareness. Mars exalted. Driving blind and given Mars' energy and determination, often blind luck. Jupiter in detriment. A tendency in confusion to withdraw rather than accept the condition and continue to persevere.

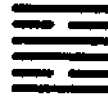
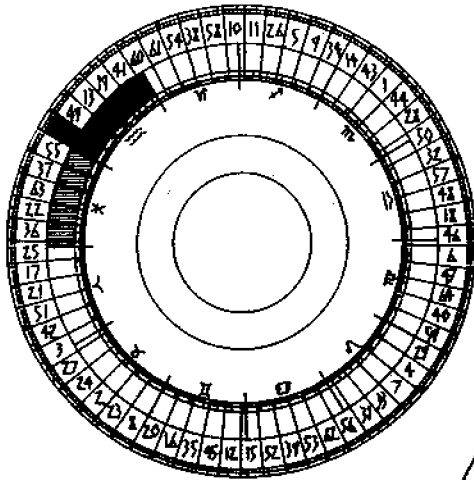

Clinging Fire

24°30'00'' ☲ - 00°07'30'' ☱

The Lines

- 1-24°30'00'' - 25°26'15''
- 2-25°26'15'' - 26°22'30''
- 3-26°22'30'' - 27°18'45''
- 4-27°18'45'' - 28°15'00''
- 5-28°15'00'' - 29°11'15''
- 6-29°11'15'' - 00°07'30''

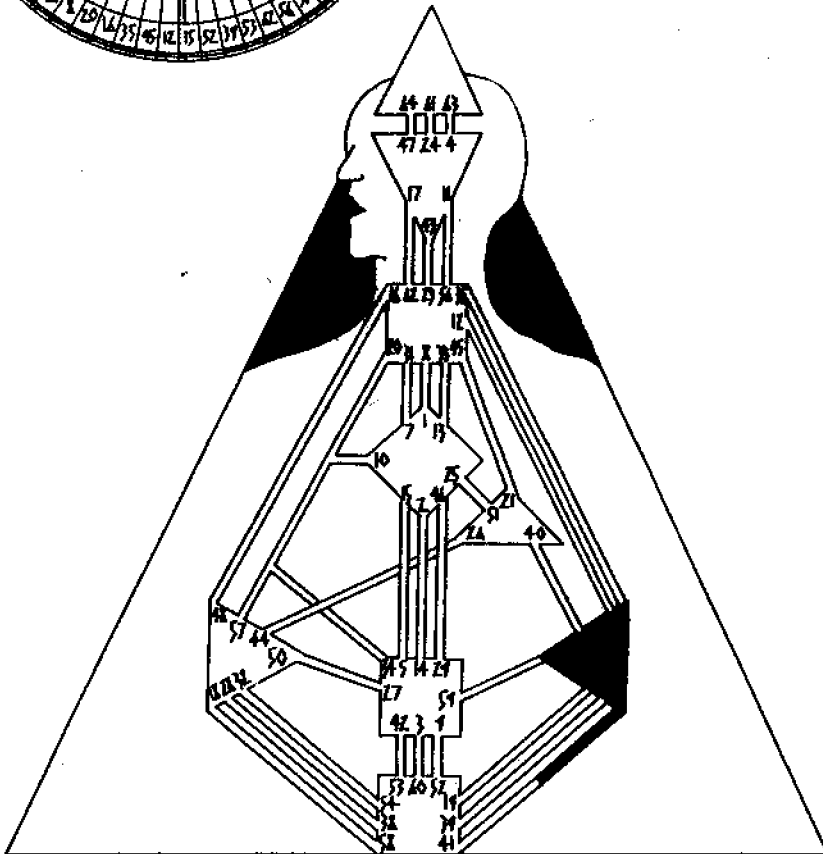

Clinging Fire

Sign (Cusp Hexagram): Aquarius-Fixed. Science Humanitarianism Music
Pisces-Mutable. Openness Devotion Conflict

Center: Solar Plexus. Aspiration Sensitivity Emotion

Gate: 30 Clinging Fire

Harmonic Gate: 41 Decrease

Channel: 30-41 Recognition. A design of focused energy

Freedom recognized as an illusion and limitation accepted as a fate.

The Lines

1 - Composure. Balance in the face of disorder. The Sun exalted. The maximization of limitation in all cases. Jupiter in detriment. The ability to maintain composure but at the expense of progress.

2 - Pragmatism. The balance between extremes. The Sun exalted. The productive application of energy without wastage. Mars in detriment. Over-aggressiveness that chafes against limitations.

3 - Resignation. The acceptance of what is. Pluto exalted. The awareness and manifestation of the law of regeneration. The laws of Karma, reincarnation and resurrection. Jupiter in detriment. The tendency by its very knowledge to encourage or avoid despair.

4 - Burnout. An unrealistic pace that begs misfortune. Pluto exalted. A compulsive and hyperactive nature that carries all the earmarks of burnout but doesn't necessarily arrive at it. A positive outcome is often assisted through analysis. Jupiter in detriment. Uncontrollable expansion with the inevitable bursting of the bubble.

5 - Irony. Recognition and dedication to transitory goals. Jupiter exalted. The strength derived from knowledge and experience that two steps forward and one step back, is still one step forward. Pluto in detriment. The anger engendered by the irony, frustration with its limitations and a desire to eliminate the entire process.

6 - Enforcement. The discipline to maintain right action. Mars exalted. The assertiveness to purge the inferior while accepting to lead the weak. The Moon in detriment. An inherent peacefulness that all too often will abide the presence of inferior forces.

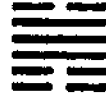
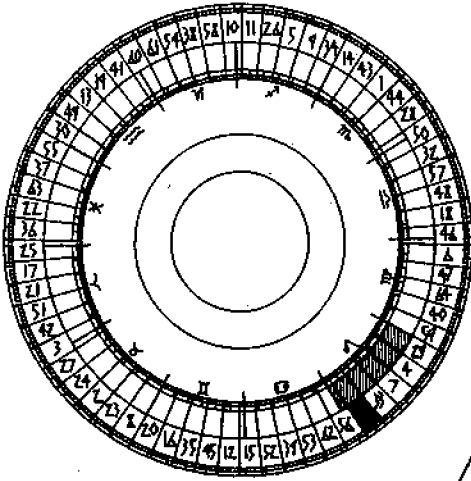

Influence

02°00'00'' - 07°37'30'' ♂

The Lines

- 1-02°00'00'' - 02°56'15''
- 2-02°56'15'' - 03°52'30''
- 3-03°52'30'' - 04°48'45''
- 4-04°48'45'' - 05°45'00''
- 5-05°45'00'' - 06°41'15''
- 6-06°41'15'' - 07°37'30''

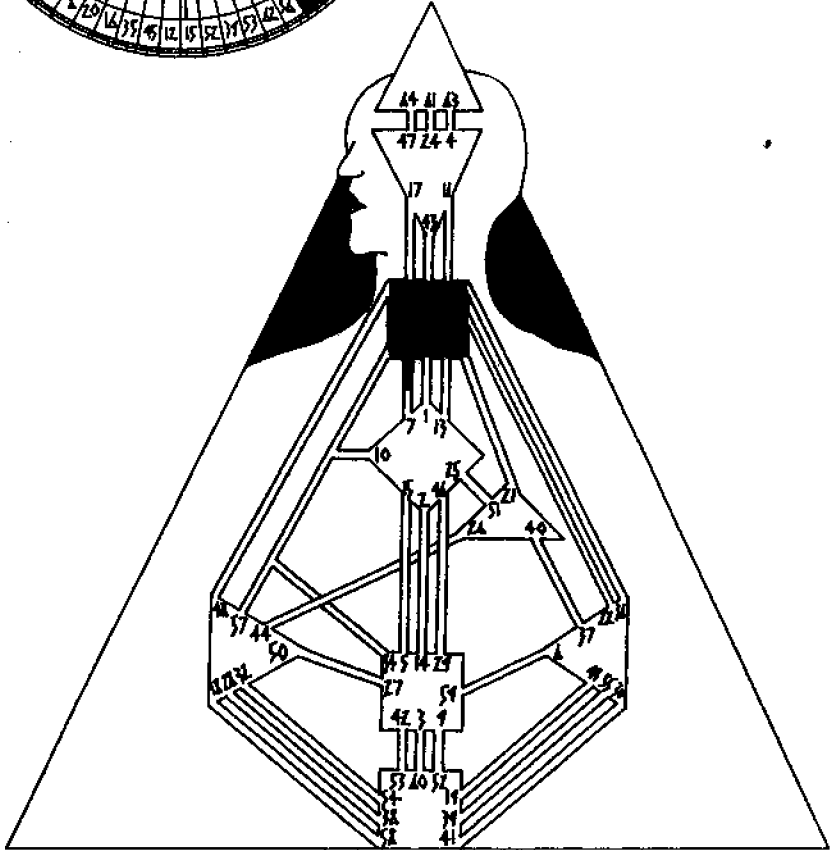

Influence

Sign: Leo-Fixed. Self-expression Pleasure Authority

Center: Throat. Action Metamorphosis Unfolding

Biology: The Thyroid and Parathyroid Glands

Gate: 31 Influence

Harmonic Gate: 7 The Army

Channel: 31-7 The Alpha. For 'good' or 'bad', the design of leadership

The law of friction, whether active or passive, that engenders transference and thus influence.

The Lines

1 - Manifestation. Influence cannot exist in a vacuum. The Sun exalted. The Sun does not/cannot hold back its light and thus its influence on every life. The Earth in detriment. The absorption of light, that in darkness can only promise manifestation.

2 - Arrogance. Independent action without guidance. Jupiter exalted. The dedication to higher principles that cannot wait for consensus. Mercury in detriment. A reasoned arrogance that out of nervous tension jumps the gun and often misfires.

3 - Selectivity. The Sun exalted. The ability to carefully assess and choose the proper influence and to tailor one's behaviour accordingly. Jupiter in detriment. Qualitative selectivity with the risk of a runaway enthusiasm that may lead to humiliation.

4 - Intent. The success of influence based on how it is perceived. The Moon exalted. Public acknowledgment of a nurturing and protective influence. Mars in detriment. Perceived ego aggrandizement and attempted manipulation.

5 - Self-righteousness. Lack of external influence guaranteed by attitude. Pluto exalted. A natural specialization that only develops in isolation. However, when the development is complete, the extremely difficult and generally impossible task of externalizing the influence. The Moon in detriment. A deep focus on personal experience that is self-fulfilling and has no external ambitions.

6 - Application. The Sun exalted. Actions which match the words and thus guarantees success. The Moon in detriment. A superficiality in application that borders on hypocrisy and is justifiably treated accordingly.

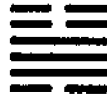

Duration

20°45'00'' - 26°22'30'' ☰

The Lines

- 1-20°45'00'' - 21°41'15''
- 2-21°41'15'' - 22°37'30''
- 3-22°37'30'' - 23°33'45''
- 4-23°33'45'' - 24°30'00''
- 5-24°30'00'' - 25°26'15''
- 6-25°26'15'' - 26°22'30''

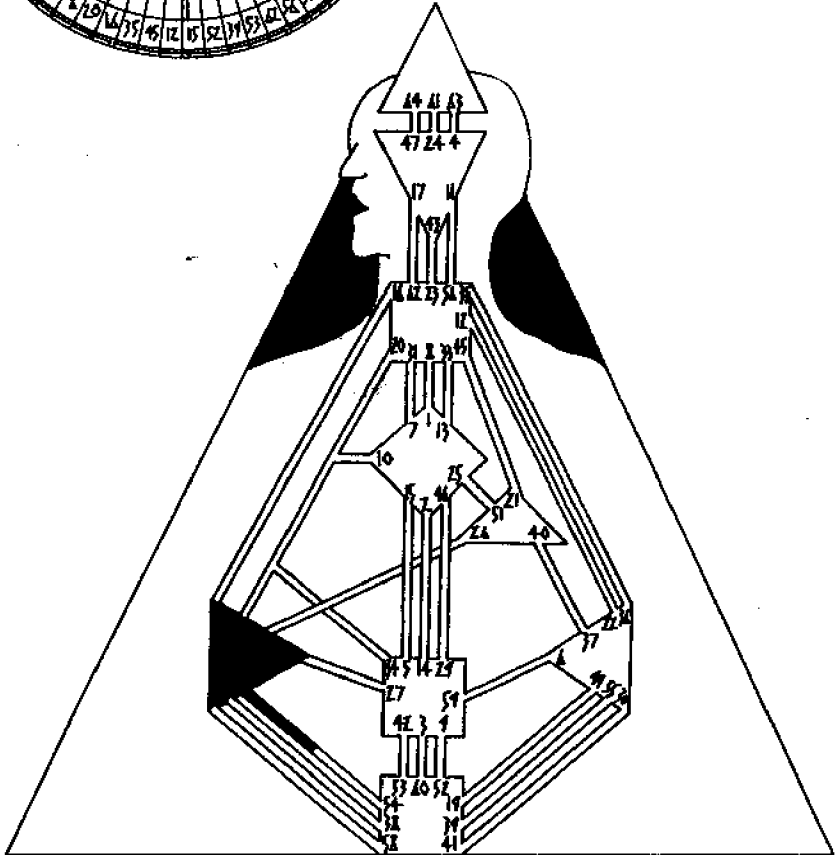
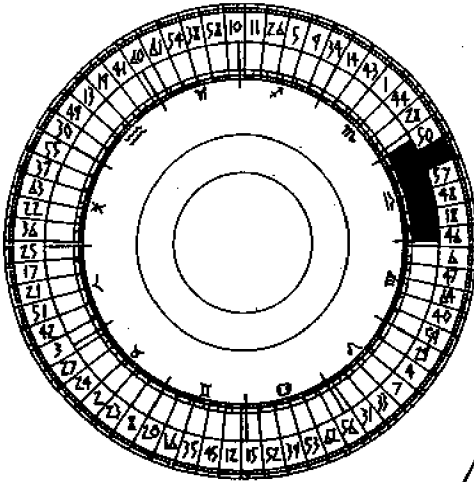

Duration

Sign: Libra-Cardinal. Comparison Appreciation Evaluation

Center: Splenic. Balance Judgment Cleansing

Biology: The Spleen and Lymph System

Gate: 32 Duration

Harmonic Gate: 54 The Marrying Maiden

Channel: 32-54 Transformation. A design of being driven

The only thing which endures is change.

The Lines

1 - Conservation. The Sun exalted. A life sustaining respect and attention to all aspects of a process. Mars in detriment. The uncontrollable urge to bypass essentials which inevitably leads to the disruption of continuity.

2 - Restraint. Venus exalted. The control of power for the benefit and enhancement of harmony. Jupiter in detriment. A tendency in frustration, particularly from a position of strength, to social withdrawal rather than persistent control.

3 - Lack of continuity. Mercury exalted. Indecision and persistent reevaluation, that only because of its basic intelligence manages to endure. Jupiter in detriment. An overreliance on traditionally legitimized standards that in times of change can be totally out of step and suffer unexpected humiliation.

4 - Right is might. Jupiter exalted. Even in times of change certain underlying principles endure. Saturn in detriment. Where Jupiter will establish right action in the larger social realm, Saturn's will lead to inner strength and endurance as long as it is not threatened from the outside.

5 - Flexibility. Easy adaption to circumstances. The Moon exalted, where superficiality is a valuable tool that while masking the inner light permits adaption to prevailing conditions. Mars in detriment. The urge to express oneself in direct and often violent rejection of conformity.

6 - Tranquillity. The need to calmly face impermanence. Pluto exalted. An underlying acceptance of change that may or may not lead to tranquillity. Neptune in detriment. Impermanence as proof of meaninglessness with its attendant manifestations, depression, delusion, and in the extreme, self-destruction.

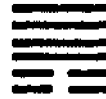
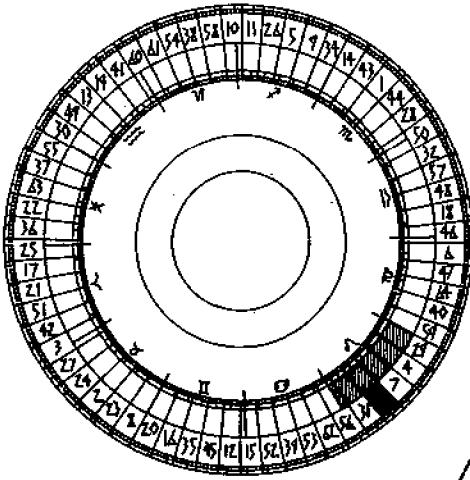

Retreat

07°37'30'' - 13°15'00'' ♀

The Lines

- 1-07°37'30'' - 08°33'45''
- 2-08°33'45'' - 09°30'00''
- 3-09°30'00'' - 10°26'15''
- 4-10°26'15'' - 11°22'30''
- 5-11°22'30'' - 12°18'45''
- 6-12°18'45'' - 13°15'00''

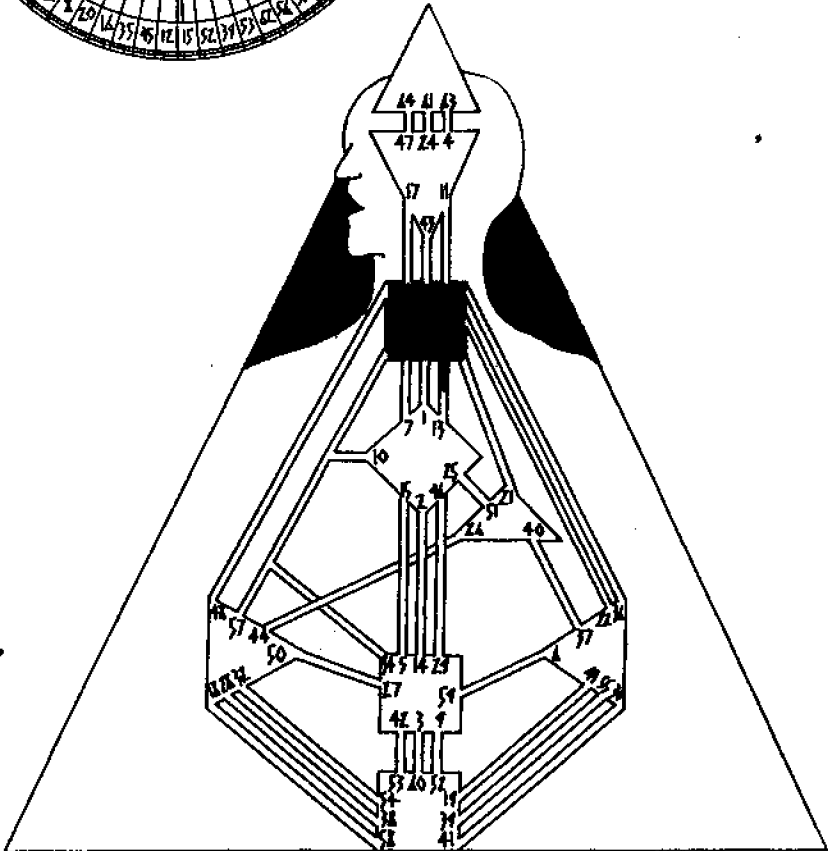

Retreat

Sign: Leo-Fixed. Self-expression Pleasure Authority

Center: Throat. Action Metamorphosis Unfolding

Biology: The Thyroid and Parathyroid Glands

Gate: 33 Retreat

Harmonic Gate: The Fellowship of Man

Channel: 33-13 The Prodigal. The design of the witness

Active withdrawal and the transformation of a weak position into a strength.

The Lines

1 - Avoidance. The Sun exalted. The wisdom in a weak position to recognize that survival demands complete withdrawal. Mars in detriment. Where courage is just plain foolishness.

2 - Surrender. Jupiter exalted. The recognition that surrender to superior forces can be an opportunity to expand one's own strengths and eventually triumph. Neptune in detriment. Unlike the reasoned and calculated surrender above, the deeper and personal surrender. The feeling that one's original position was a delusion and the impressionability that makes might right.

3 - Spirit. The attitude that turns retreat into victory. Jupiter exalted. The responsible and principled retreat based on preservation but with the determination to persevere. Mars in detriment. A lack of responsibility in retreat. The bridge burner.

4 - Dignity. A lack of turmoil in retreat. Pluto exalted. The underlying faith in resurrection that turns retreat into an opportunity for renewal and regeneration. Neptune in detriment. Without the guiding light of resurrection, the inevitable dissolution that leads to degeneration.

5 - Timing. Pluto exalted. As important as the timing itself, is the ability to keep secret one's intentions until the appropriate moment. Jupiter in detriment. The tendency to want others to participate in the selection of the timing, which can lead to confusion.

6 - Disassociation. The ability to let go. The Sun exalted. The will to concentrate on revitalization and not be handicapped by persistent recriminations. Jupiter in detriment. The ability to shed the larger framework that precipitated the retreat, leaving nagging doubts that hamper revitalization.

The Power of the Great

Sign: Sagittarius-Mutable. Philosophy Religion Idealism

Center: Sacral. Maturation Reproduction Sexuality

Biology: The Ovaries and the Testes

Gate: 34 Power of the Great Harmonic Gate: 20 Contemplation
10 Treading
57 The Gentle

Channels: 34-20 Charisma. A design where thoughts must be deeds
34-10 Exploration. A design of following one's convictions
34-57 Power. A design of an archetype

Power is only great when its display or use serves the common good.

The Lines

1 - The Bully. The indiscriminate use of power. Saturn exalted. The less negative, the resort to power as a manifestation of frustration. Pluto in detriment. The comeuppance that is the inevitable destiny of the bully.

2 - Momentum. Mars exalted. The ability, when victory is in sight, not to lose perspective. Venus in detriment. A tendency to be emotionally carried away by the smell of victory.

3 - Machismo. The indiscriminate display of power. Saturn exalted. The great malefic, where machismo unfortunately is invariably backed up by power. This is an exaltation only in that it is natural and not contrived. Mercury in detriment. A reasoned and calculated display. The communication of disinformation.

4 - Triumph. The freedom in absolute victory to unlimited use of power. Pluto exalted. A tendency in victory to restrain excessive power in favour of more subtle and covert styles. Mars in detriment. Ego gratification in the unrestrained use of power with impunity, inevitably leading to abuse.

5 - Annihilation. The total elimination of resistance. Mars exalted. The power to destroy completely and once this is accomplished, the ability to transfer the power to normal purposes. The Moon in detriment. A difficulty in shedding the patterns established to deal with resistance. Symbolized by its phases, the feeling that nothing is permanently annihilated.

6 - Common sense. Knowing when enough is enough. The Earth exalted. The good sense when having bitten off more than one can chew to spit part of it out. Jupiter in detriment. Enthusiasm overriding better judgment, invariably leads to complications.

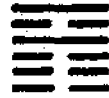
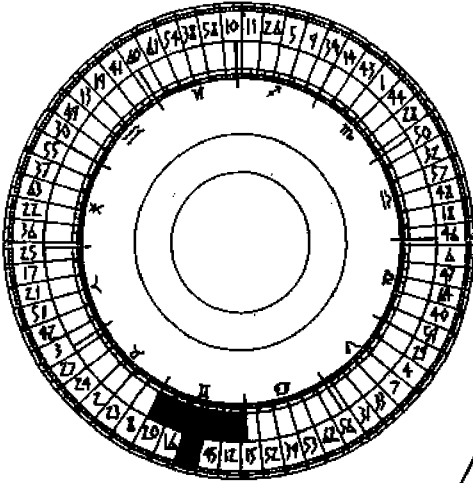

Progress

11°22'30'' - 17°00'00'' II

The Lines

- 1-11°22'30'' - 12°18'45''
- 2-12°18'45'' - 13°15'00''
- 3-13°15'00'' - 14°11'15''
- 4-14°11'15'' - 15°07'30''
- 5-15°07'30'' - 16°03'45''
- 6-16°03'45'' - 17°00'00''

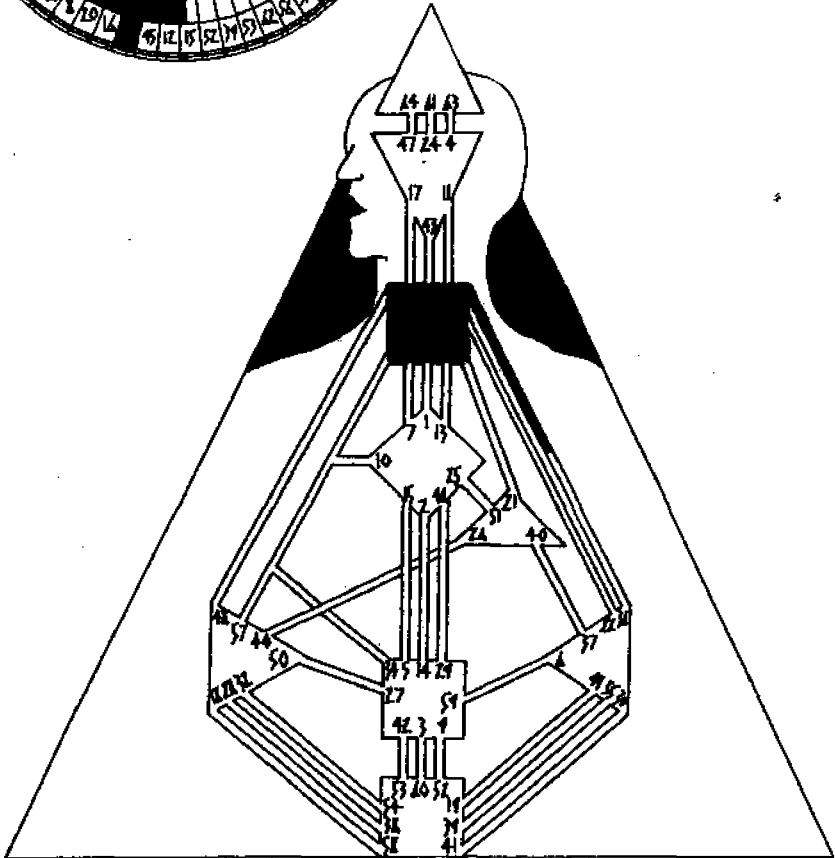

Progress

Sign: Gemini-Mutable. Changeability Duality Expansion

Center: Throat. Action Metamorphosis Unfolding

Biology: The Thyroid and Parathyroid Glands

Gate: 35 Progress

Harmonic Gate: 36 The Darkening of the Light

Channel: 35-36 Transitoriness. A design of a 'Jack of all Trades'

By design, progress cannot exist in a vacuum and is dependent on interaction.

The Lines

1 - Humility. The ability to accept rejection. Venus exalted. The artist that accepts rejection as part of the process. Neptune in detriment. A self-destructive reaction to rejection. Loss of worth.

2 - Creative block. Lack of inspiration which stops progress. Venus exalted. Attunement with the vagaries of the muse and the recognition, creativity is energy that ebbs and flows. The Moon in detriment. The need to take action, however mundane, to overcome the feeling of emptiness. The actions being uninspired do not further progress.

3 - Collaboration. The whole is greater than the sum of its parts. Jupiter exalted. Benefic encouragement of others that expands personal as well as communal progress. The Sun in detriment. The need to be the center that ignores the importance of others.

4 - Hunger. The insatiable appetite for progress. The Moon exalted. Less severe. Symbolized by the phases of the Moon, the drive may be obsessive when the Moon is full, but like the fading of the Moon the obsession abates. Mars in detriment. The abuse of position to accumulate perks with the inevitable retribution from those unfairly deprived.

5 - Altruism. The sacrifice of personal for communal progress. Mercury exalted. The principles of interaction and harmony communicated successfully for the benefit of the whole. Jupiter in detriment, though altruistic and cooperative in general, a personal regret that in interaction a greater personal expansion had been lost.

6 - Rectification. The energy to correct. Saturn exalted. The process of crystallization coupled with ambition that assures timely and effective correction. Mars in detriment. A destructive tendency that in its personal application may be the necessary severity to ensure correction but when applied generally, it will meet with resistance and tend to reinforce rather than rectify situations.

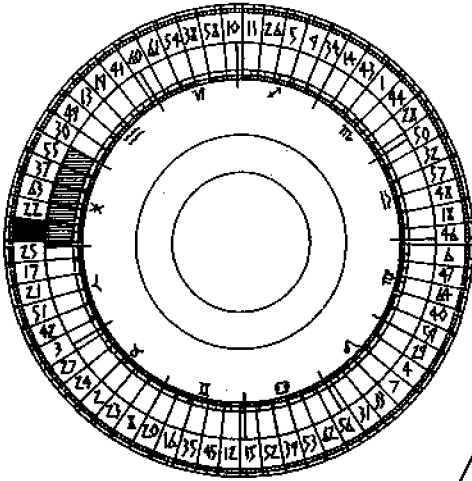

The Darkening of the Light

22°37'30'' - 28°15'00'' ✕

The Lines

- 1-22°37'30'' - 23°39'45''
- 2-23°33'45'' - 24°30'00''
- 3-24°30'00'' - 25°26'15''
- 4-25°26'15'' - 26°22'30''
- 5-26°22'30'' - 27°18'45''
- 6-27°18'45'' - 28°15'00''

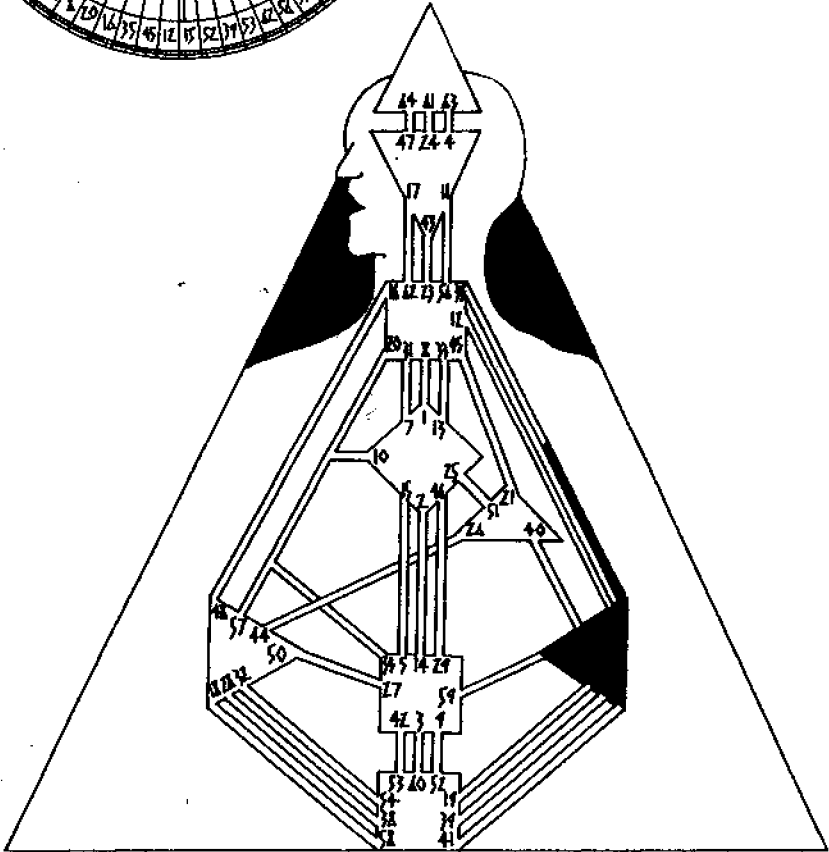

The Darkening of the Light

Sign: Pisces-Mutable. Openness Devotion Conflict

Center: Solar Plexus. Aspiration Sensitivity Emotion

Biology: The Kidney and Pancreas

Gate: 36 Darkening of the Light

Harmonic Gate: 35 Progress

Channel: 36-35 Transitoriness. A design of a 'Jack of all Trades'

The rule of Cycles in which decline is a natural but not enduring stage.

The Lines

1 - Resistance. Mars exalted. The energy and determination to persevere in the face of opposition. Jupiter in detriment. An over-principled resistance that rather than being selective in resistance and thus less at risk, will maintain normal patterns and incur opposition.

2 - Support. Assistance to others in times of decline. Neptune exalted. The application of imagination to schemes which benefit others. The Moon in detriment. The more practical and individual assistance but only when unavoidable and not as a general principle.

3 - Transition. The point at which decline has exhausted its power. Pluto exalted. The ability to establish a new order out of the ashes of the old. Jupiter in detriment. The tendency in renewal to try to assimilate the remains of the old order into the new with the risk that it may rise against the new order once it has regained its strengths.

4 - Espionage. Pluto exalted. The ability to prepare for and anticipate decline through the accumulation of secret or privileged information. The Moon in detriment. The tendency in recognizing the strengths of the opposition to accept the inevitability of decline and rather than resist, to offer one's services to guarantee survival. The double agent.

5 - The underground. Pluto exalted. Perfected survival regardless of conditions. Mercury in detriment. A nervousness that can lead to self-betrayal.

6 - Justice. The inevitable survival of right. Jupiter exalted. The knowledge and attendant faith that the powers of darkness eventually destroy themselves. 'Those whom the Gods wish to destroy, they first make mad.' Saturn in detriment. A profound sorrow and cynicism, that is not diminished by the understanding, that darkness is self-annihilating.

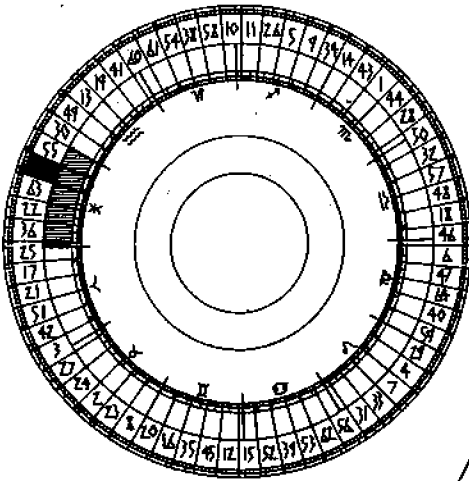

The Family

05°45'00'' - 11°22'30'' ✕

The Lines

- 1-05°45'00'' - 06°41'15''
- 2-06°41'15'' - 07°37'30''
- 3-07°37'30'' - 08°33'45''
- 4-08°33'45'' - 09°30'00''
- 5-09°30'00'' - 10°26'15''
- 6-10°26'15'' - 11°22'30''

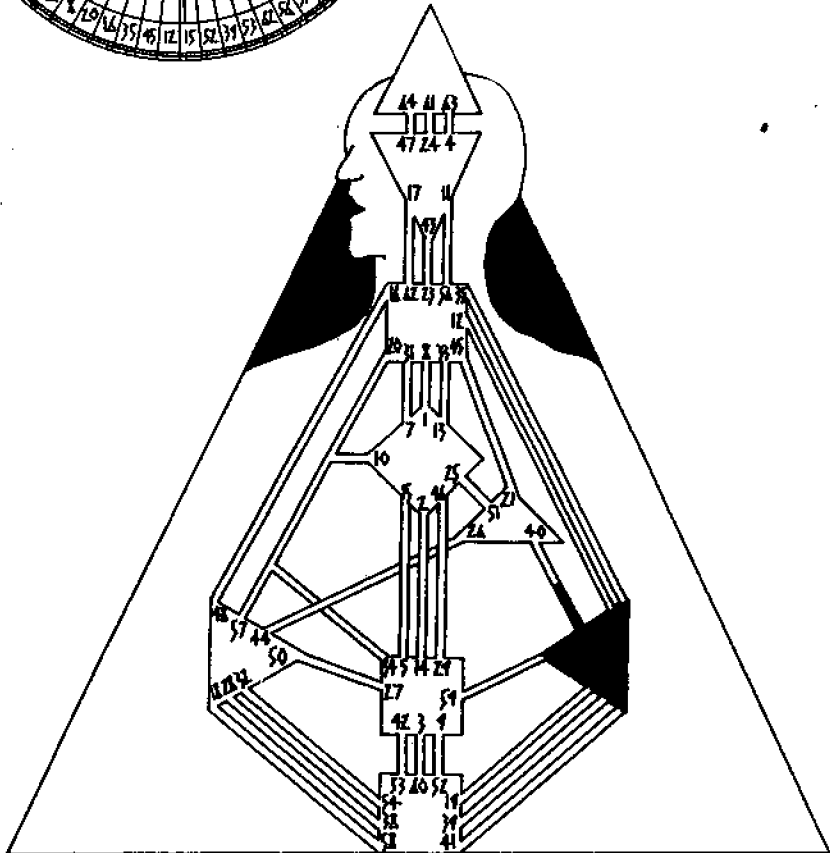

The Family

Sign: Pisces-Mutable. Openness Devotion Conflict

Center: Solar Plexus. Aspiration Sensitivity Emotion

Biology: The Kidney and Pancreas

Gate: 37 The Family

Harmonic Gate: 40 Deliverance

Channel: 37-40 Community. A design of being a part seeking a whole

The manifestation macro- and micro-cosmically of the organic nature of communities.

The Lines

1 - The Mother/Father. A position of inherent respect that ensures a focus for the development of guidelines. Venus exalted. Harmony is the key to the successful maintenance of relationships. It is only through harmony that the beauty and the values of the family can endure. There is no planet in detriment.

2 - Responsibility. Jupiter exalted. The understanding of the principle of individual responsibility as the foundation for successful cooperation. Mercury in detriment. A tendency to point out the responsibility of others.

3 - Evenhandedness. The success of any group is dependent on maintaining order. Jupiter exalted. The ability to judge what behaviour is appropriate and to react in a balanced manner to transgressions. Mars in detriment. An ironic tendency to either test incessantly the borders of acceptability or to respond to the very same tendency in others with severity.

4 - Leadership by example. Any member of the family may take on a leading role through exemplary behaviour. The Moon exalted. The manifestation of the highest principles in everyday and practical affairs. Saturn in detriment. A conservatism that generally only accepts the leadership of the father, who may or may not be a valued role model.

5 - Love. Natural and unaffected devotion to the family. Venus exalted. Natural harmony and perfected sharing. Mars in detriment. Emotional dependency that often turns love into hatred.

6 - Purpose. The energy to maintain the family is enhanced by recognizing its values. Venus exalted. The gift of not only recognizing the inner meaning of the family but an appreciation for its values. Mercury in detriment. A need for diversity that may ignore the achievements of the family in favour of withdrawal.

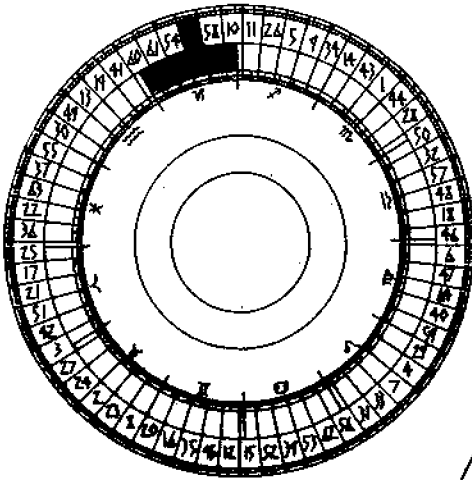

Opposition

09°30'00'' - 15°07'30'' W

The Lines

- 1-09°30'00'' - 10°26'15''
- 2-10°26'15'' - 11°22'30''
- 3-11°22'30'' - 12°18'45''
- 4-12°18'45'' - 13°15'00''
- 5-13°15'00'' - 14°11'15''
- 6-14°11'15'' - 15°07'30''

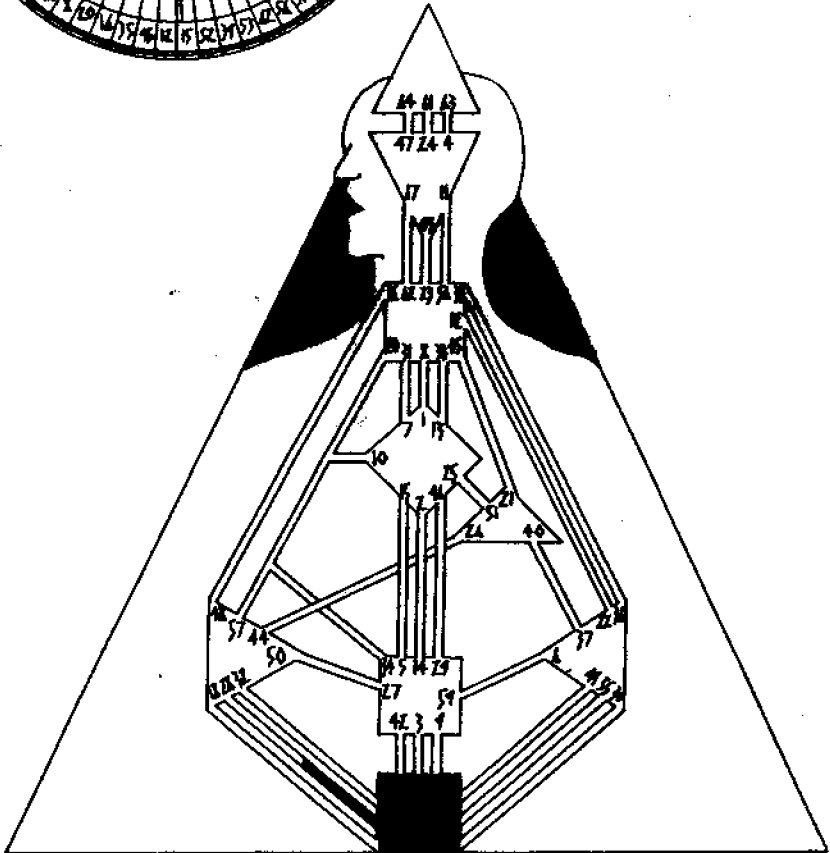

Opposition

Sign: Capricorn-Cardinal. Ambition Government Status

Center: The Base of the Spine. Assertion Energy Evolution

Biology: The Adrenal Glands

Gate: 38 Opposition

Harmonic Gate: 28 Preponderance of the Great

Channel: 38-28 Struggle. A design of stubbornness.

The ability to preserve individual integrity through opposition to detrimental forces.

The Lines

1 - Qualification. Tempering opposition based on the circumstances. Neptune exalted. A psychic attunement that guarantees proper action. Mars in detriment. The tendency to oppose as a general rule.

2 - Politeness. Opposition that does not transgress normal codes of behaviour. Pluto exalted. The value of discretion. The Moon in detriment. An over-politeness that is both servile and obviously superficial and defeats its very purpose.

3 - Alliance. The Sun exalted. The ability to sustain through integration with similar forces, thus ensuring the vitality to persevere. The Earth in detriment. Selfish alliance which saps the energy of one's partners, in order to ensure personal vitality.

4 - Investigation. Analysis which strengthens opposition. Pluto exalted. The detective who develops or the insider who accepts a joint opposition whose success can only be based on trust. Mars in detriment. The aggressiveness in opposition that prejudices investigation and limits trustworthiness.

5 - Alienation. A stage in opposition when one is totally isolated. Saturn exalted. The ambition and concentration to endure. Pluto in detriment. Alienation experienced as painful confinement that by its very nature blinds one to the possibility that there are those at some point who may come to one's aid.

6 - Misunderstanding. Opposition without basis. Saturn exalted. Eventual crystallization which clears up misunderstandings. The Earth in detriment. The recognition that misunderstanding is at the root of opposition but the insistence, that it is the misunderstanding of the opposing forces.

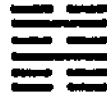

Obstruction

09°30'00'' - 15°07'30'' ☰

The Lines

- 1-09°30'00'' - 10°26'15''
- 2-10°26'15'' - 11°22'30''
- 3-11°22'30'' - 12°18'45''
- 4-12°18'45'' - 13°15'00''
- 5-13°15'00'' - 14°11'15''
- 6-14°11'15'' - 15°07'30''

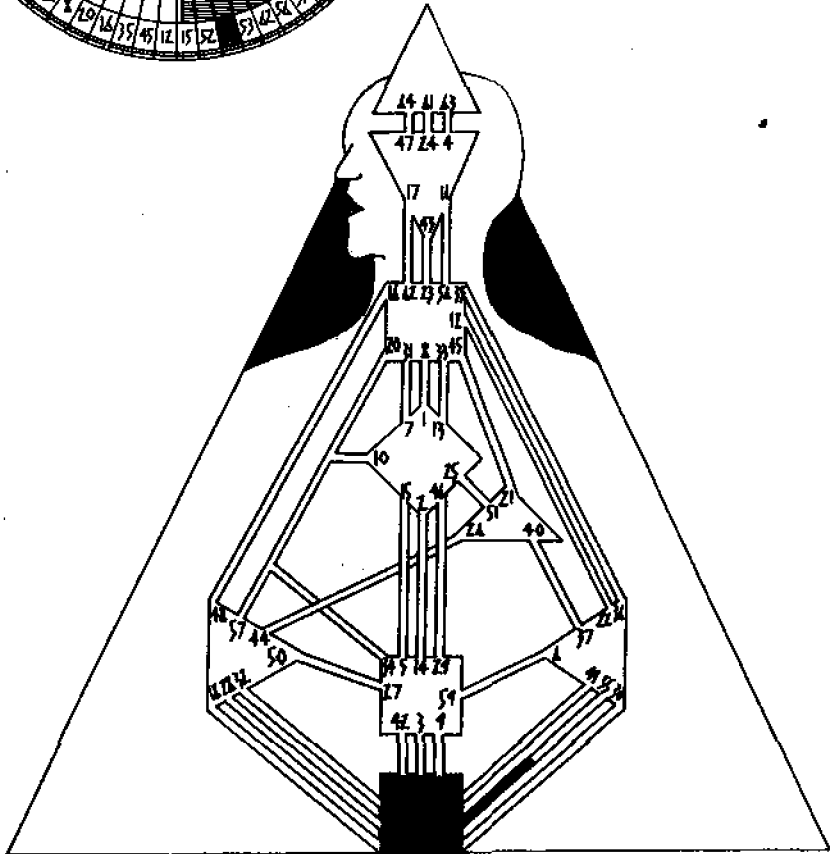
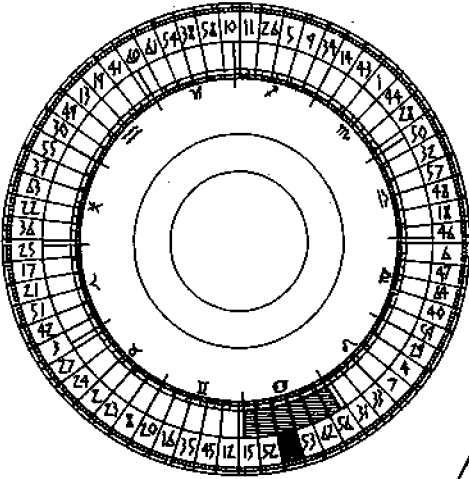

Obstruction

Sign: Cancer-Cardinal. Receptivity Sensitivity Home

Center: The Base of the Spine. Assertion Energy Evolution

Biology: The Adrenal Glands

Gate: 39 Obstruction

Harmonic Gate: 55 Abundance

Channel: 39-55 Emoting. A design of moodiness

The value of obstruction in provoking analysis, assessment and reevaluation.

The Lines

1 - Disengagement. Mars exalted. The determination when confronted by obstacles to withdraw but only temporarily. Mercury in detriment. Disengagement, with an accompanying indecision as to when to reengage.

2 - Confrontation. The Moon exalted. The instinctual and direct assault of obstacles. Jupiter in detriment. The principle of preservation that tempts one to go around an obstacle that should be tackled head-on.

3 - Responsibility. The avoidance of confronting obstacles if failure puts others at risk. Jupiter exalted. The great benefic whose first consideration is for the larger framework. The Earth in detriment. The often disastrous assumption that others are more at risk if an obstacle is not confronted.

4 - Temperance. Careful evaluation and assessment before taking action. The Moon exalted. The values of feelings and instincts in establishing the proper timing. The Sun in detriment. The faulty belief that willpower alone can overcome any obstacle regardless of circumstances.

5 - Single-mindedness. The rare ability not to overcome but to bypass obstacles. Neptune exalted. The imagination to establish new patterns that make the obstacles irrelevant. Mars in detriment. Simple hardheadedness. Though less exalted, it can often result in success and gather support by its very determination.

6 - The troubleshooter. The natural gift for solving problems. The Moon exalted. Practicality and the ability to guide and nurture others. Mars in detriment. Ego dominance that generally abuses this gift for self-aggrandizement and personal ambition rather than for the benefit of others.

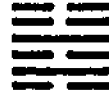
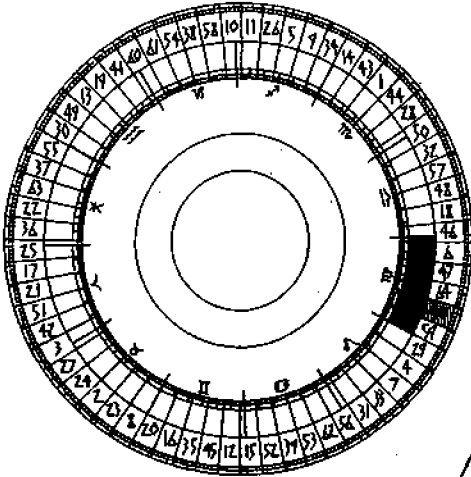

Deliverance

05°45'00'' - 11°22'30'' 11P

The Lines

- 1-05°45'00'' - 06°41'15''
- 2-06°41'15'' - 07°37'30''
- 3-07°37'30'' - 08°33'45''
- 4-08°33'45'' - 09°30'00''
- 5-09°30'00'' - 10°26'15''
- 6-10°26'15'' - 11°22'30''

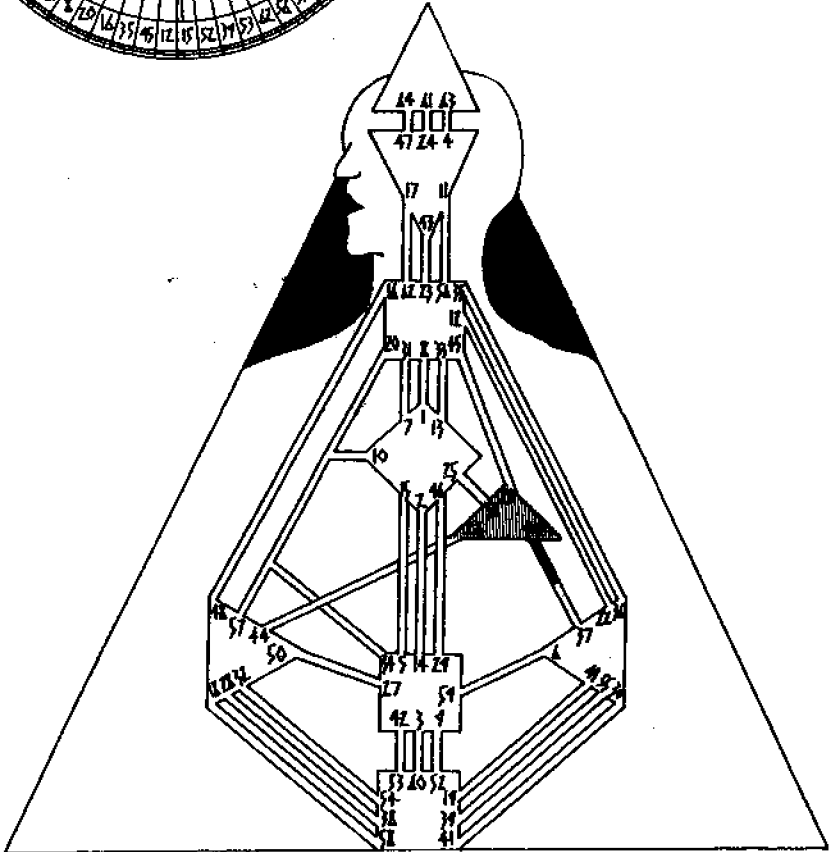

Deliverance

Sign: Virgo-Mutable. Mental detail: Service Judgmentation

Center: Heart. Ego Zeal Passion

Biology: The Thymus Gland

Gate: 40 Deliverance

Harmonic Gate: 37 The Family

Channel: 40-37 Community. A design of being a part seeking a whole

The point of transition between struggle and liberation.

The Lines

1 - Recuperation. The Sun exalted. The ability to relax and enjoy the fruits of one's labours. The Moon in detriment. The Moon cannot stand still.

2 - Resoluteness. The Sun exalted. The power and authority in deliverance to shed forever the qualities which hampered liberation. The Moon in detriment. A natural peacefulness that in deliverance may sympathize with and attempt to nurture the forces which hampered liberation.

3 - Humility. A calculated mode in deliverance to avoid attracting the attention of negative forces. Pluto exalted. The subtlety to enjoy deliverance without having to flaunt it. Mars in detriment. The ego arrogance that demands attention and gets it.

4 - Organization. Uranus exalted. The power to transform and the intuitive intellect to select and organize for the purpose of maintaining deliverance. Mars in detriment. An uncontrollable zeal that ignores the quality of support in preference for the quantity which in the long run may destabilize deliverance.

5 - Rigidity. The recognition that to achieve liberation all negative forces must be rejected. Uranus exalted. The revolutionary that demands absolute victory. The Earth in detriment. A tendency in revolution to accept a certain amount of necessary deviation on the assumption that it can be successfully purged later.

6 - Decapitation. The necessary destruction of inferior forces in positions of power before liberation can take place. The Sun exalted. The authority, coupled with the magnanimity to remove from power only those which deserve such drastic treatment. The Earth in detriment. Exemplified by the terror of the French Revolution, where the idea of who was deserving of punishment was cruelly extended to an entire class.

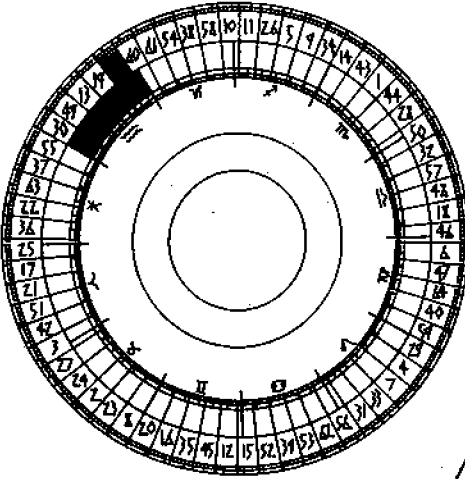

Decrease

02°00'00" - 07°37'30" ☵

The Lines

- 1-02°00'00" - 02°56'15"
- 2-02°56'15" - 03°52'30"
- 3-03°52'30" - 04°48'45"
- 4-04°48'45" - 05°45'00"
- 5-05°45'00" - 06°41'15"
- 6-06°41'15" - 07°37'30"

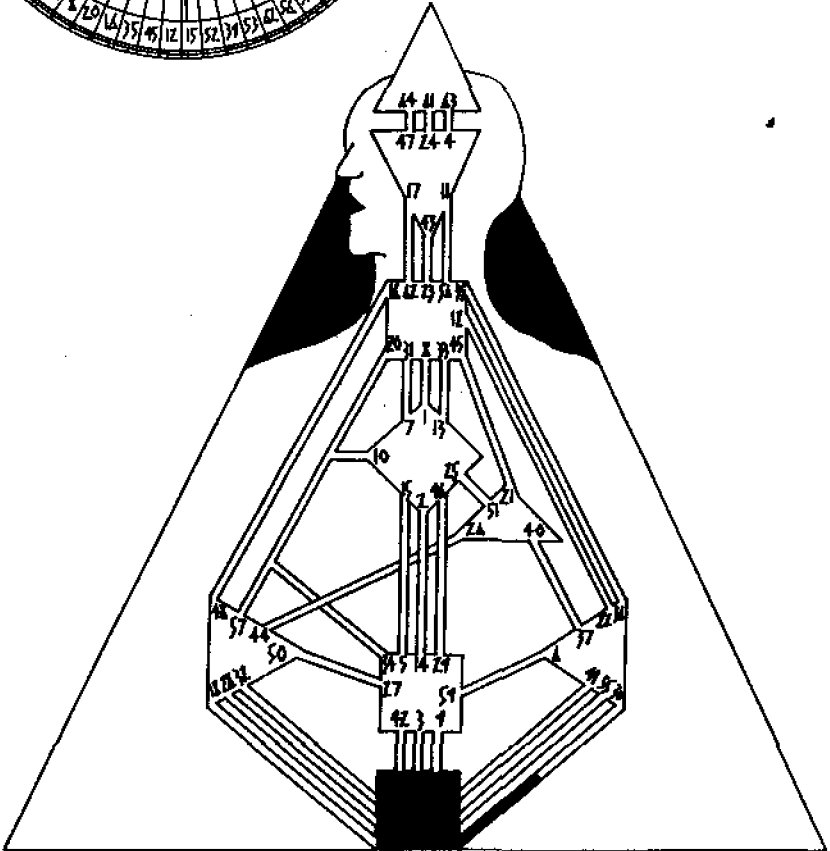

Decrease

Sign: Aquarius-Fixed. Science Humanitarianism Music

Center: The Base of the Spine. Assertion Energy Evolution

Biology: The Adrenal Glands

Gate: 41 Decrease

Harmonic Gate: 30 The Clinging Fire

Channel: 41-30 Recognition. A design of focused energy

The limitation of resources which maximizes development of potential.

The Lines

1 - Reasonableness. The appropriate delegation of responsibility. Neptune exalted. The imagination to make the very best out of very little. Mercury in detriment. A tendency in understanding, to assume capability, leading to strain.

2 - Caution. Humanism tempered by pragmatism. Saturn exalted. A conservative nature that does not risk its own security in aiding others. Mars in detriment. A desire for recognition that throws caution to the wind, depleting valuable resources for only temporary gain.

3 - Efficiency. In times of decrease selfishness is justified. Saturn exalted. Material ambition and the discipline to go at it alone. The Moon in detriment. Instinctive assistance, admirable but in this position misguided, where two will use up resources twice as fast as one.

4 - Correction. Successful adaptation to limitation. The Earth exalted. Survival of the fittest and its eventual flourishing. Venus in detriment. The expenditure of energy on maintaining relationships rather than on correction. In times of decrease weak associations are shunned as costly, no matter how attractive.

5 - Authorization. The external recognition of one's potential despite limitations. Mars exalted. The value of energy when properly channelled. Venus in detriment. A persistent dissatisfaction with limitation which hampers development even when supported.

6 - Contagion. The law that the maximization of potential not only ends decrease but inevitably such transcendence benefits others. Saturn exalted. The maximization of the potential of form. The father whose success will benefit his children. Pluto in detriment. The tendency in transcendence to keep it a secret in fear of being deprived of its special advantages.

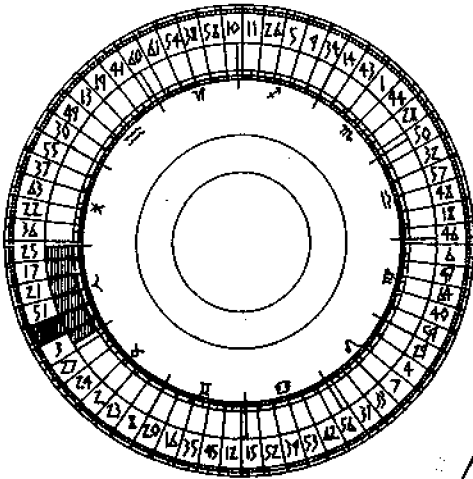

Increase

 $20^{\circ}45'00'' - 26^{\circ}22'30'' \text{ Y}$

The Lines

- | | | | |
|----|---------------------|---|---------------------|
| 1- | $20^{\circ}45'00''$ | - | $21^{\circ}41'15''$ |
| 2- | $21^{\circ}41'15''$ | - | $22^{\circ}37'30''$ |
| 3- | $22^{\circ}37'30''$ | - | $23^{\circ}33'45''$ |
| 4- | $23^{\circ}33'45''$ | - | $24^{\circ}30'00''$ |
| 5- | $24^{\circ}30'00''$ | - | $25^{\circ}26'15''$ |
| 6- | $25^{\circ}26'15''$ | - | $26^{\circ}22'30''$ |

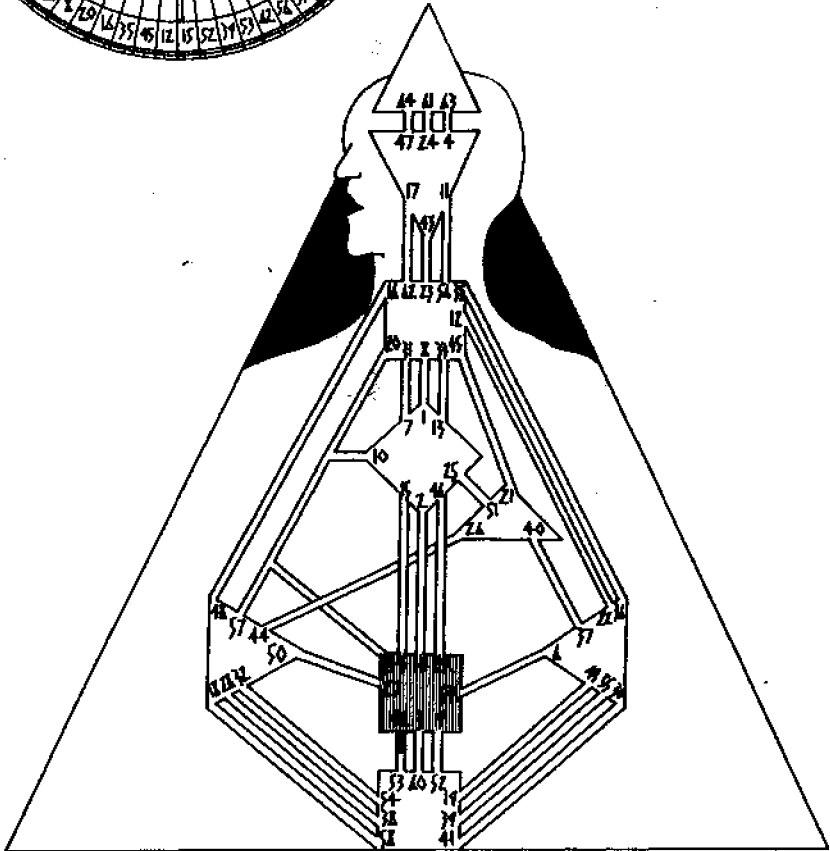

Increase

Sign: Aries-Cardinal. Desire Will Impulse Courage

Center: Sacral. Maturation Reproduction Sexuality

Biology: The Ovaries and the Testes

Gate: 42 Increase

Harmonic Gate: 53 Development

Channel: 42-53 Maturation. A design of balanced development

The expansion of the resources which maximizes the development of full potential.

The Lines

1 - Diversification. The Sun exalted. The ability when surplus resources are available to extend one's activities beyond their normal scope. Venus in detriment. A tendency when surplus resources are available to centrifugal application. Decadence.

2 - Identification. The Sun exalted. Recognition and acute capitalization of trends. Venus in detriment. An ascetically motivated withdrawal in times of progressive change.

3 - Trial and error. In times of increase, mistakes are a natural part of the process. Mars exalted. The energy and assertion to turn mistakes into advantages. The Moon in detriment. A moodiness, that in error may succumb to brooding and unnecessary caution.

4 - The middle man. The Moon exalted. The quintessential manifestation of the mediator. Venus in detriment. Where the gift to establish and maintain relationships is ill-suited in this position to act in mediation where harmony must take a back seat to pragmatism.

5 - Self-actualization. The Sun exalted. The fulfillment and actualization of purpose as a natural path whose reward is a healthy sense of self, rather than the power and influence that naturally follow. Venus in detriment. Self-actualization as a strictly inner experience that may demand or result in a reclusive nature.

6 - Nurturing. The Moon exalted. A natural and instinctive nurturing of others. Saturn in detriment. A restrictive and malefic materialism that is self-alienating and encourages aggression.

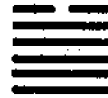

Breakthrough

18°52'30'' - 24°30'00'' 711-

The Lines

- 1-18°52'30'' - 19°48'45''
- 2-19°48'45'' - 20°45'00''
- 3-20°45'00'' - 21°41'15''
- 4-21°41'15'' - 22°37'30''
- 5-22°37'30'' - 23°33'45''
- 6-23°33'45'' - 24°30'00''

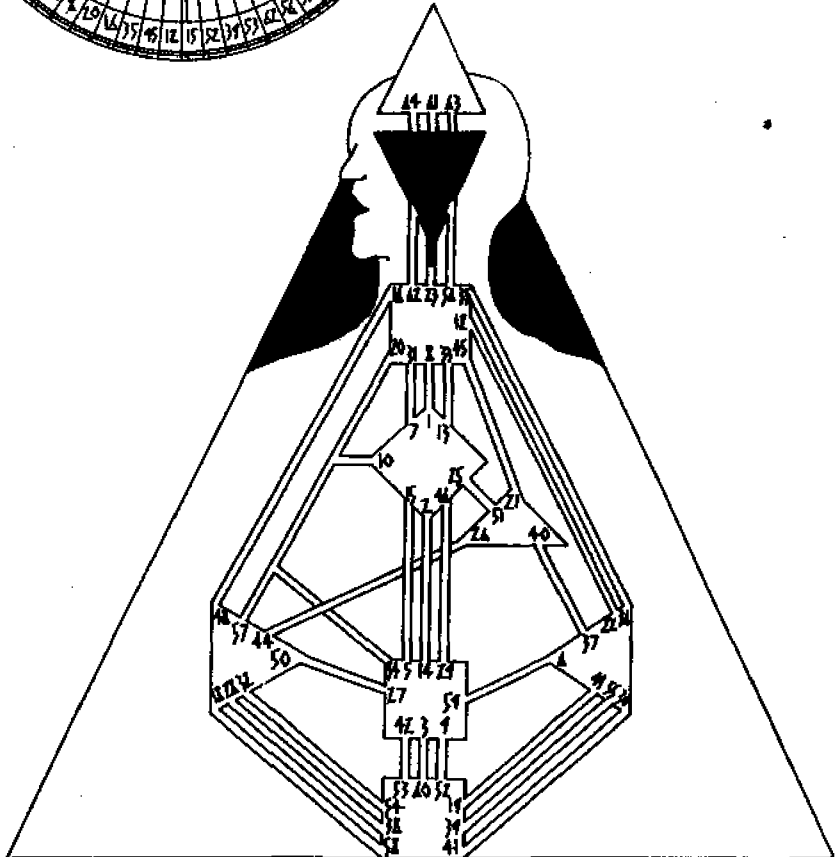
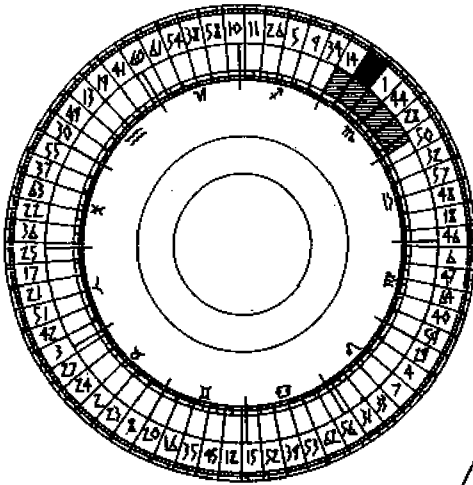

Breakthrough

Sign: Scorpio-Fixed. Transcendence Sex Death Regeneration

Center: Ajna. Knowing Intuition Understanding

Biology: The Anterior and Posterior Pituitary Glands

Gate: 43 Breakthrough

Harmonic Gate: 23 Splitting Apart

Channel: 43-23 Structuring. A design of individuality
(Genius to Freak)

In order for achievement to be maintained a new order must be fairly established.

The Lines

1 - Patience. Pluto exalted. The recognition that new forms cannot be established until resistance has been eliminated. Venus in detriment. An impatience to enjoy the sweets of accomplishment that inevitably leaves a sour taste in the mouth.

2 - Dedication. Pluto exalted. The maintenance of specialized attitudes which promote breakthrough. The Moon in detriment. A dedication to action, that when actualization is in sight may become incautious.

3 - Expediency. Pluto exalted. The powerful drive for regeneration that will, when breakthrough is threatened, use any means, align with any force and endure any condemnation to achieve the goal. The Moon in detriment. An oversensitivity to condemnation, that may preclude justified expediency and result in failure.

4 - The one-track mind. Mercury exalted. The over-reliance and stubborn obsession with one's mental abilities in the face of recurring obstacles. This design, given Mercurial mental gifts, may though rarely succeed. Jupiter in detriment. A belief in inherent right action based on limited knowledge that shuns advice.

5 - Progression. The Moon exalted. The step by step adaptation to relationships which hinder breakthrough through practical actions which will not jeopardize eventual success. Venus in detriment. A tendency to concentrate on harmonizing relationships that tends to strengthen the position of restrictive forces rather than benefiting breakthrough.

6 - Breakthrough. The Sun exalted. Actualization and centering, that in breakthrough naturally establish both internally and externally a new order. Mars in detriment. An ego tendency that in breakthrough sees justification of its lesser attributes and carries them over into the new order.



Coming to Meet

07°37'30'' - 13°15'00'' W

The Lines

- 1-07°37'30'' - 08°33'45''
- 2-08°33'45'' - 09°30'00''
- 3-09°30'00'' - 10°26'15''
- 4-10°26'15'' - 11°22'30''
- 5-11°22'30'' - 12°18'45''
- 6-12°18'45'' - 13°15'00''

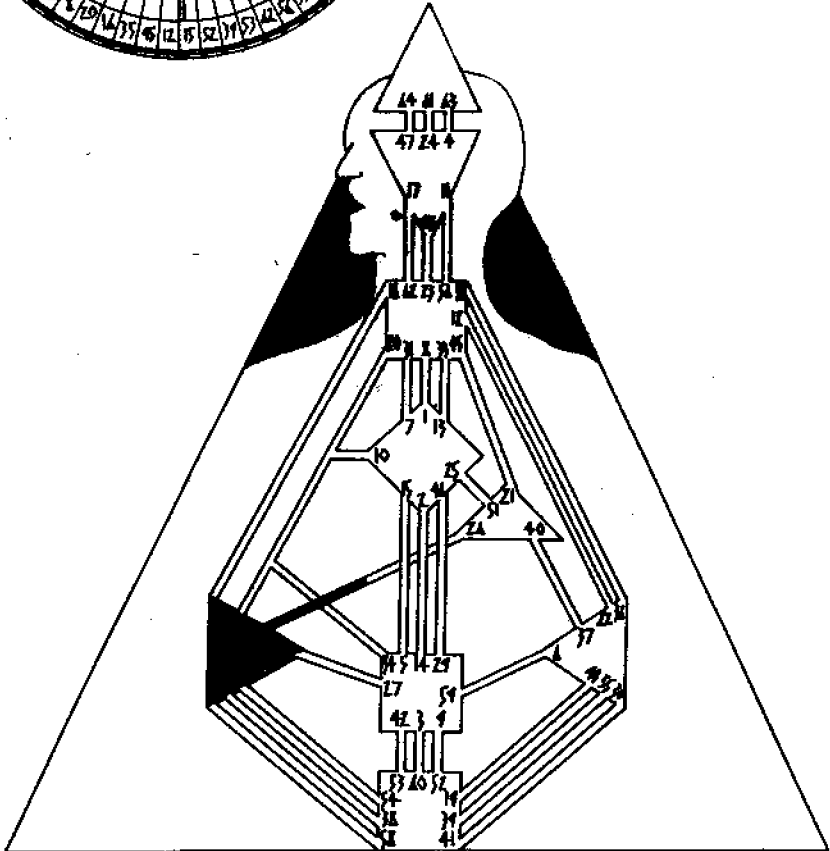
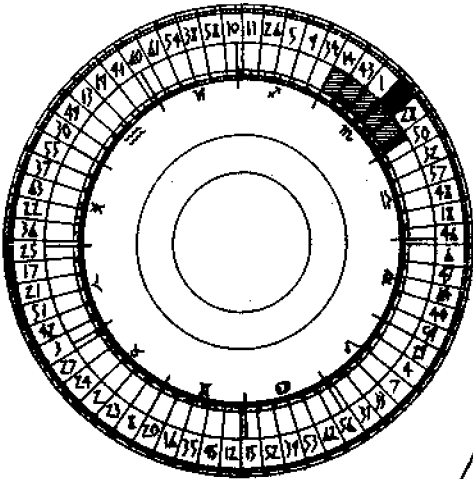

Coming to Meet

Sign: Scorpio-Fixed. Transcendence Sex Death Regeneration

Center: Splenic. Balance Cleansing Judgment

Biology: The Spleen and Lymph System

Gate: 44 Coming to Meet

Harmonic Gate: 26 Taming Power of the Great

Channel: 44-26 Surrender. A design of a transmitter

The success of any interaction is based on the absence of any preconditions.

The Lines

1 - Conditions. The establishment of frameworks as the result of interaction. Pluto exalted. A mastery of the collective that can establish restrictive conditions for inferior components and with the ability to enforce them. Venus in detriment. An attractive nature that will interact with inferior forces and will fail to apply restrictions resulting in a risk to continued harmony.

2 - Management. Jupiter exalted. The development and management of a proper collective structure which restricts inferior elements by creating cooperative modes that integrates these forces with progressive and superior forces. Mars in detriment. A tendency in management to concentrate exclusively on goals, ignoring inferior elements which leads inevitably to quantitative success and qualitative failure.

3 - Interference. The failure to interact based on circumstances. Mars exalted. The ability to recognize the threat of interference and to prepare for its effects. Neptune in detriment. A deluded response to interference that gets stuck in projection and as a result is unrealistic in appraisal and error prone.

4 - Honesty. The refusal to engage in hypocritical interaction. Pluto exalted. Indifference at its most logical and cutting. The Sun in detriment, that in extreme situations, in cases of self-sustainment, will expect assistance from forces it has totally rejected. Here the honesty is the genuine need.

5 - Manipulation. Uranus exalted. The ability to transform interaction with inferior elements into the energizing of progressive process with the additional benefit, that in tapping the inferior elements they remain weak. Mars in detriment. The tendency in this form of manipulation to become abusive and degenerate to their level.

6 - Aloofness. Pluto exalted. A perfected renewal in which the establishment of a new form inures one to the condemnation of the rejected. The Earth in detriment. Intolerance and arrogance for lesser mortals.



Gathering Together

17°00'00'' - 22°27'30'' II

The Lines

- 1-17°00'00'' - 17°56'15''
- 2-17°56'15'' - 18°52'30''
- 3-18°52'30'' - 19°48'45''
- 4-19°48'45'' - 20°45'00''
- 5-20°45'00'' - 21°41'15''
- 6-21°41'15'' - 22°37'30''

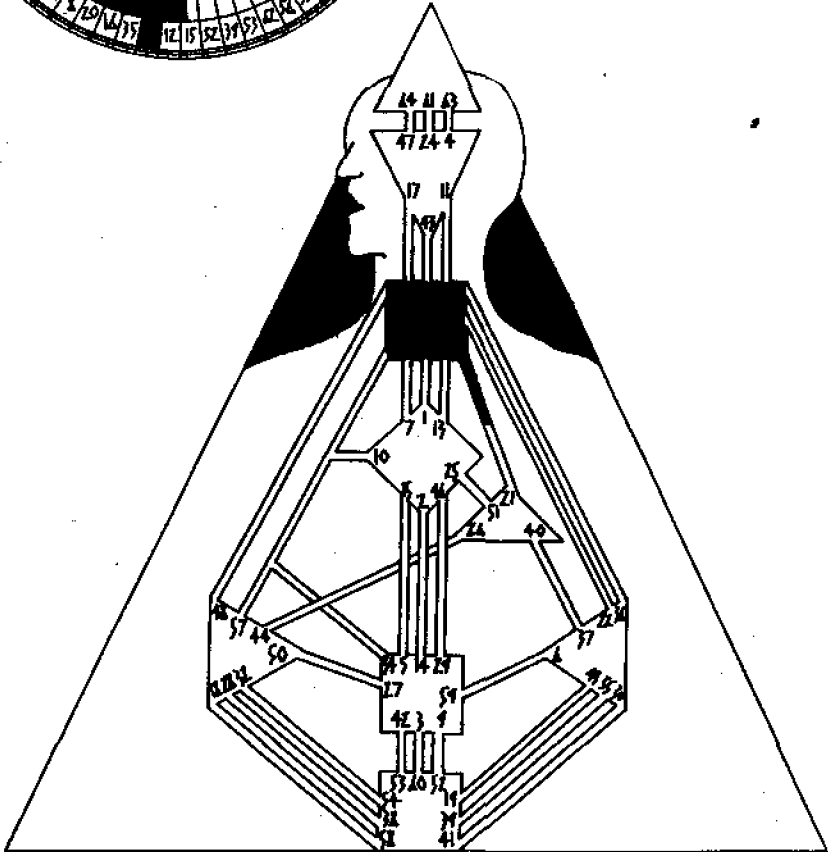
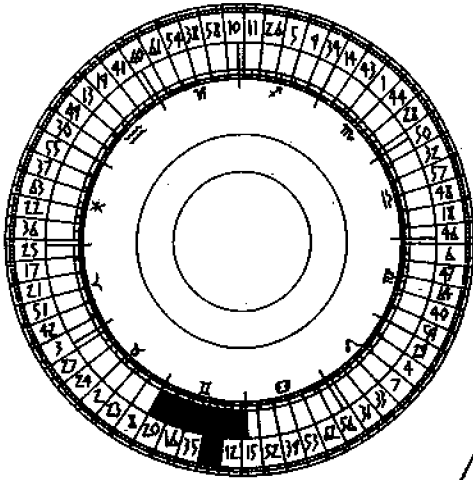

Gathering Together

Sign: Gemini-Mutable. Changeability Duality Expansion

Center: Throat. Action Metamorphosis Unfolding

Biology: The Thyroid and Parathyroid Glands

Gate: 45 Gathering Together

Harmonic Gate: 21 Biting Through

Channel: 45-21 The Money Line. A design of a materialist

The natural and generally beneficial attraction of like forces.

The Lines

1 - Canvassing. Jupiter exalted. The ability to promote and develop gathering together through the education of the uncommitted. Mars in detriment. An over-zealousness that turns canvassing into proselytization and tends to alienate rather than gather support.

2 - Consensus. Gathering together is strengthened by acknowledged common interest. Uranus exalted. The inventiveness to establish techniques by which common ground can be assessed. Mars in detriment. An innate rebellion against conformity.

3 - Exclusion. Neptune exalted. The ability when excluded to take whatever measures are necessary to dissolve the antiquated form and to accept even humiliation to achieve inclusion. Mars in detriment. An aggressive and often violent reaction to exclusion.

4 - Direction. Jupiter exalted. The ability to focus the opportunity of gathering together for the service of higher principles. Mars in detriment. The tendency to try to influence the direction of a group action for personal benefit.

5 - Leadership. All gathering together must have a center and a focus. Uranus exalted. The intuitive intellect and gift for innovation that enhance the group effort and ensure continuity through respect of the center. Jupiter in detriment. A sense of right action that assumes a respect that may not as yet have been earned.

6 - Reconsideration. An outsider that can admit that its prior rejection was an error, will generally be accepted into the gathering. Uranus exalted. An innate empathy with the outsider mentality and its eccentric and often misunderstood logic. Jupiter in detriment. Where Uranus will innovate to find a place for an outsider, Jupiter will demand that it conforms.

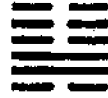
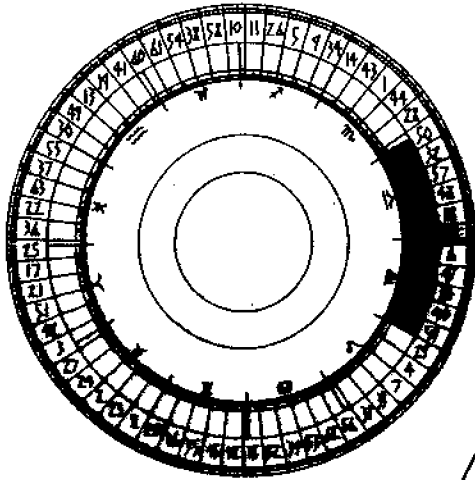

Pushing Upward

28°15'00'' 17' - 03°52'30'' ☰

The Lines

- 1-28°15'00'' - 29°11'15''
- 2-29°11'15'' - 00°07'30''
- 3-00°07'30'' - 01°03'45''
- 4-01°03'45'' - 02°00'00''
- 5-02°00'00'' - 02°56'15''
- 6-02°56'15'' - 03°52'30''

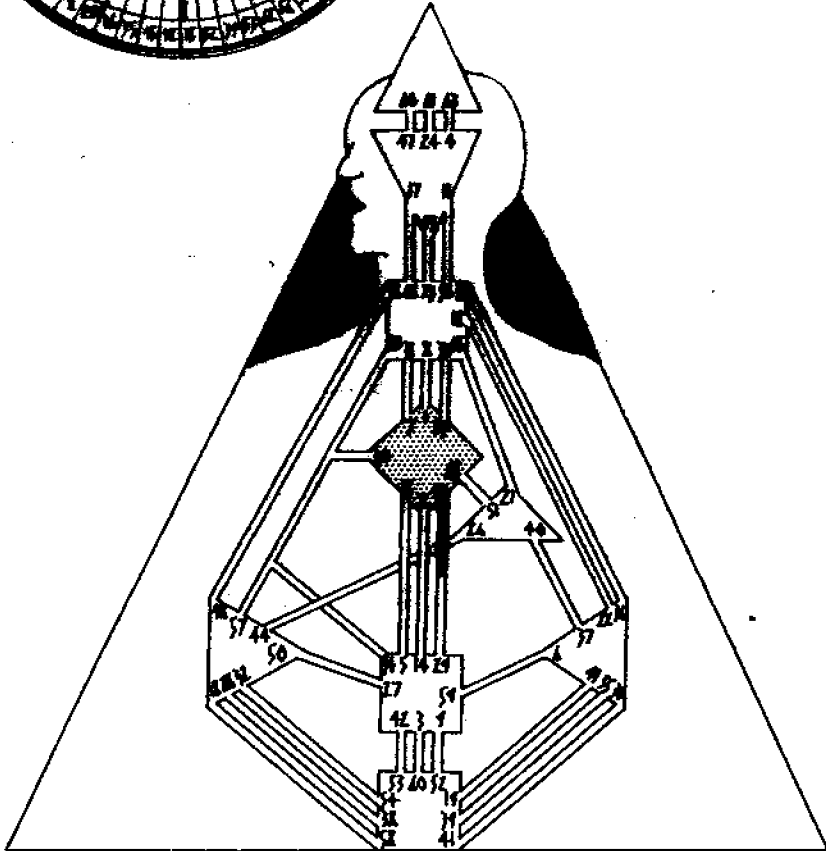

Pushing Upward

Sign (Cuep Hex.): Virgo-Mutable. Mental detail Service
Judgmentation

Libra-Cardinal. Comparison Appreciation Evaluation

Center: G Center. Spirituality Gravity Attraction Love

Biology: The Liver

Gate: 46 Pushing Upward

Harmonic Gate: 29 The Abysmal

Channel: 46-29 Discovery. A design of succeeding where
others fail

Good fortune that may be perceived as the result of
serendipity but derives from effort and dedication.

The Lines

1 - Being discovered. Dedication in obscurity that is un-
expectedly discovered. Neptune exalted. Art for art's sake.
Any creative endeavour that is self-fulfilling sooner or
later is recognized. Jupiter in detriment. The ability to
judge the potential of those in obscurity but often solely
to benefit one's own success.

2 - The Prima Donna. The Sun exalted. A difficult and de-
manding nature that succeeds despite its behaviour because
of the depth of its talents. Mars in detriment. Unrealistic
demands and offensive nature of egocentric mediocrity.

3 - Projection. The Moon exalted. A practical approach to
good fortune, that maintains the same patterns and attitudes
that brought success and does not get side-tracked by in-
dulging in further expectations. Mars in detriment. A tend-
ency through projection to treat a potential future as the
present, leading to unjustified egoism and the loss of mo-
mentum and support.

4 - Impact. The Earth exalted. The ability, once recognized,
to move rapidly from a position of obscurity to influence.
Pluto in detriment. A reaction in achievement that tends to
bite off the hand that fed it.

5 - Pacing. The Moon exalted. The maintenance of proper
rhythm that in its instinctive practicality avoids radical
divergence from successful patterns. Neptune in detriment.
An irrational rejection of the very patterns that have
proven successful.

6 - Integrity. Saturn exalted. The wisdom to secure one's
identity through careful consideration of the restrictive
potential of commitments. Neptune in detriment. Deceiving
oneself and others by over-extending one's resources and
eventually being in the position of having to break
promises.

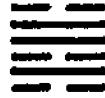
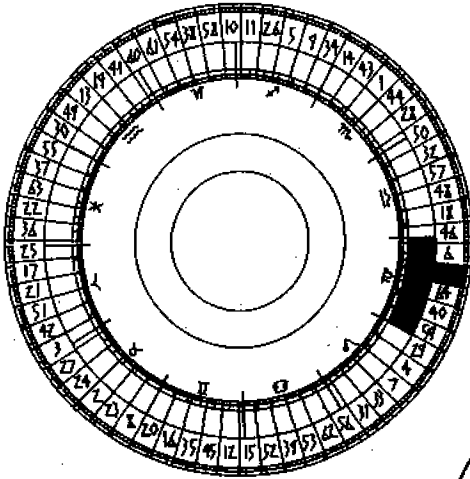

Oppression

17°00'00" - 22°37'30" 117

The Lines

- 1-17°00'00" - 17°56'15"
- 2-17°56'15" - 18°52'30"
- 3-18°52'30" - 19°48'45"
- 4-19°48'45" - 20°45'00"
- 5-20°45'00" - 21°41'15"
- 6-21°41'15" - 22°37'30"

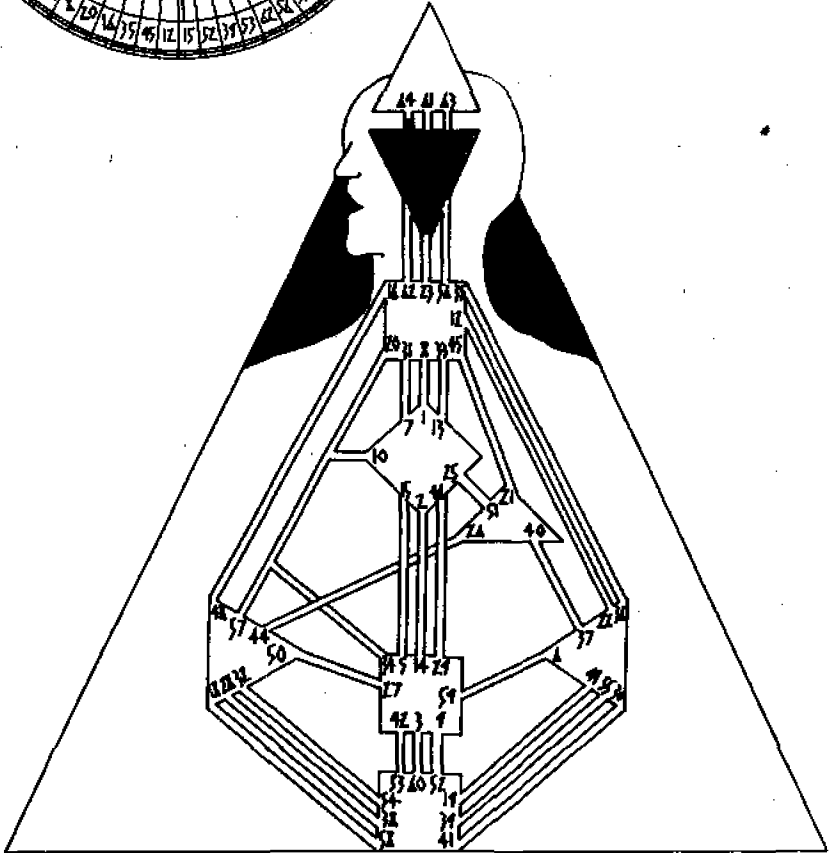

Oppression

Sign: Virgo-Mutable. Mental detail Service Judgmentation

Center: Ajna. Knowing Intuition Understanding

Biology: The Anterior and Posterior Pituitary Glands

Gate: 47 Oppression

Harmonic Gate: 64 Before Completion

Channel: 47-64 Abstraction. A design of mental activity and clarity

A restrictive and adverse state as a result of internal weakness or external strength or both.

The Lines

1 - Taking stock. Saturn exalted. The ability in times of hardship to concentrating on eradicating the negative factors that have led to oppression. Neptune in detriment. The delusion of seeing oppression as an exclusively external phenomenon with often disastrous results.

2 - Ambition. Saturn exalted. The ambition and drive to overcome personal oppression in order to achieve security. Mercury in detriment. An indecisiveness in times of personal oppression, whether to apply intelligence to recovery or accept its weight to take advantage of other prevailing conditions that may only be temporary.

3 - Self-oppression. Jupiter exalted. The conscious and well integrated being whose natural right action will eventually come to see the unfoundedness of its oppression. Mars in detriment. A self-oppression so highly energized that it may prove irreversible and destructive.

4 - Repression. The constraints of external oppression. Saturn exalted. The strength of identity that even in times of the most powerful oppression can maintain its resources and to some extent ensure their survival for the benefit of others. The Moon in detriment. When robbed of its light, the Moon is lost in darkness; barely able to nourish itself, let alone others.

5 - The saint. This position has special significance and there is no planet in detriment. Venus exalted. The gift in times of oppression to maintain without hypocrisy a harmonic relationship with one's oppressors, while providing aid and succour to the oppressed.

6 - Futility. A difficult position for which there is no exaltation. The Sun in detriment, where the strength of will alone may find a way to adapt and survive, but without hope of ever overcoming the oppression.

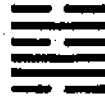
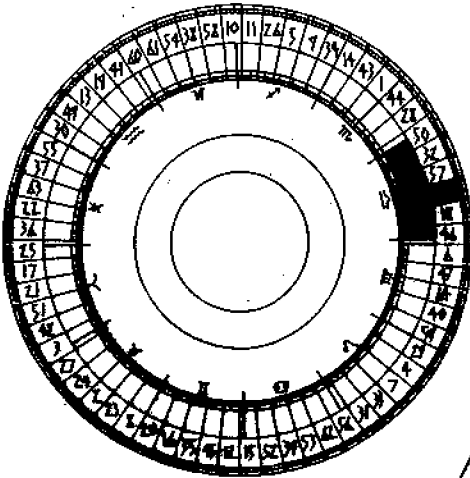

The Well

09°30'00'' - 15°07'30'' ☵☷

The Lines

- 1-09°30'00'' - 10°26'15''
- 2-10°26'15'' - 11°22'30''
- 3-11°22'30'' - 12°18'45''
- 4-12°18'45'' - 13°15'00''
- 5-13°15'00'' - 14°11'15''
- 6-14°11'15'' - 15°07'30''

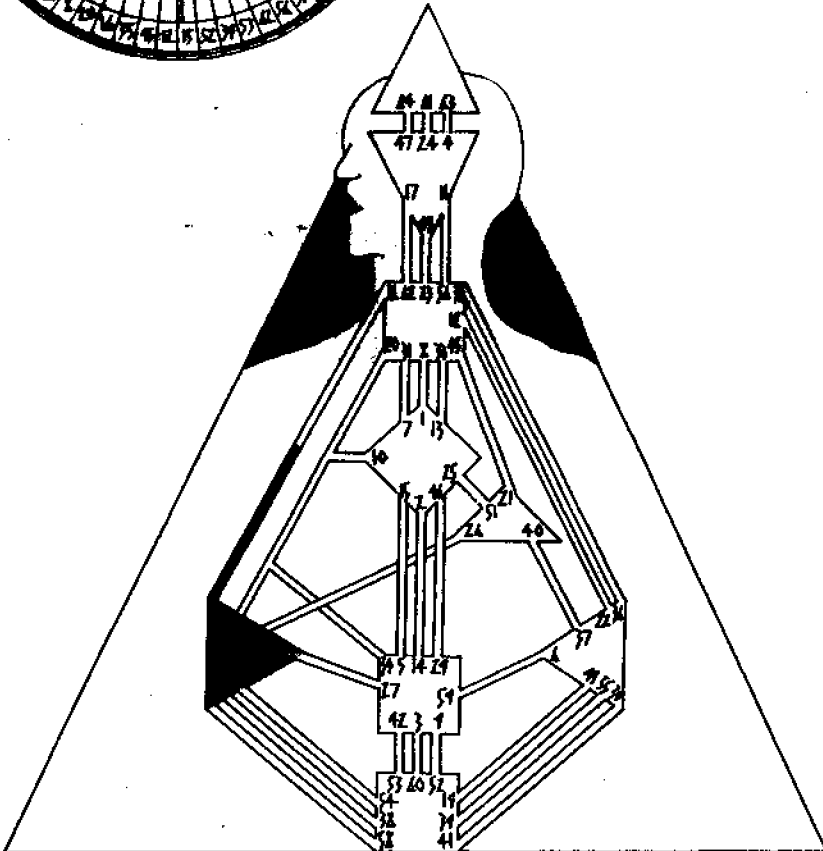

The Well

Sign: Libra-Cardinal. Comparison Appreciation Evaluation

Center: Splenic. Balance Judgment Cleansing

Biology: The Spleen and Lymph System

Gate: 48 The Well

Harmonic Gate: 16 Enthusiasm

Channel: 48-16 The Wave Length. A design of talent

The necessary and qualitative foundation that is a prerequisite to establish the common good.

The Lines

1 - Insignificance. The Moon exalted. An instinctive recognition of what is practical and deserves attention. Mars in detriment. An ego tendency to apply energy to trivial considerations.

2 - Degeneracy. Pluto exalted. The awareness that to successfully establish a new form one cannot neglect the most positive attributes just to accommodate inferior elements. This would lead to deterioration. Venus in detriment. The misguided urge for harmony that degenerates when associated with inferior values into decadence.

3 - Incommunicado. The Moon exalted. Symbolized by the 'no Moon' phase, where the potential of light is unrecognized, unavailable and unknowable. The redeeming value is in the transience of such a stage which can give strength to those so afflicted. Mercury in detriment. The profound anxiety when a profound intelligence is forgotten in the wilderness.

4 - Restructuring. The Sun exalted. The good sense to take advantage of restriction on short term activity to assess the situation and restructure for long term goals that will facilitate development when activity resumes. The Earth in detriment. A resistance to restructuring on speculation, with the tendency when activity resumes to have to do so anyway.

5 - Action. Mars exalted. The natural urge to apply energy to action. The Moon in detriment. An over-reliance on the need for protection that in times of social renewal is obsessed with the details of planning at the expense of action.

6 - Self-fulfillment. An undiminishable resource. Venus exalted. The valued center, that as it gives, it receives and thus can continue to give. The Moon in detriment. A tendency to superficiality, that though generous and nurturing, will lack the inspirational quality that can transform its gift into a common currency.

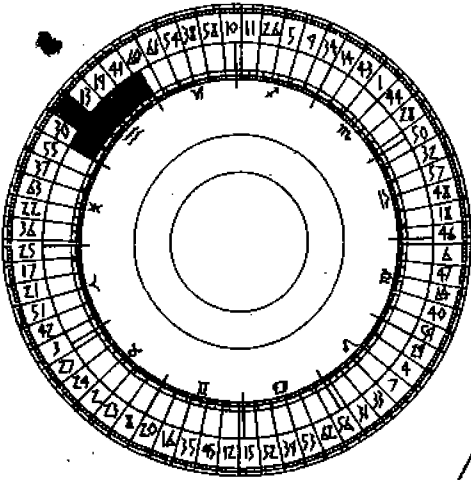

Revolution

18°52'30'' - 24°30'00'' ☲

The Lines

- 1-18°52'30'' - 19°48'45''
- 2-19°48'45'' - 20°45'00''
- 3-20°45'00'' - 21°41'15''
- 4-21°41'15'' - 22°37'30''
- 5-22°37'30'' - 23°33'45''
- 6-23°33'45'' - 24°30'00''

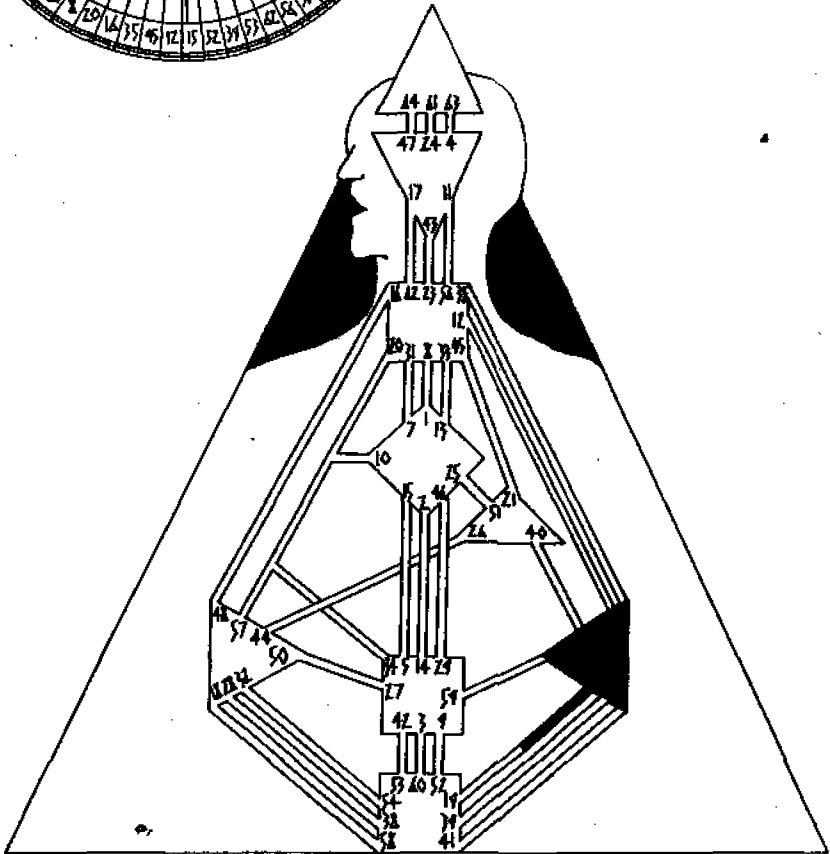

Revolution

Sign: Aquarius-Fixed. Science Humanitarianism Music

Center: Solar Plexus. Aspiration Sensitivity Emotion

Biology: The Kidney and Pancreas

Gate: 49 Revolution

Harmonic Gate: 19 Approach

Channel: 49-19 Synthesis. A design of being sensitive

Ideally the transformation of forms based on the highest principles and not simply for power.

The Lines

1 - The law of necessity. Revolution has no support unless it is perceived as necessary. Jupiter exalted. The understanding and application of this law to maximize expansion of support and thereby ensure viability. The Sun in detriment. The misuse of influence, to insist that necessity can be created out of action. The 'Helter Skelter' syndrome. To commit acts of disorder as proof that disorder exists.

2 - The last resort. The Earth exalted. The determination to exhaust every possible peaceful avenue for change and then when satisfied that no other course is possible, to plan in detail before revolution is attempted. Pluto in detriment. The overwhelming revolutionary urge that is impatient with accommodation and negotiation. The tendency here is the coup d'etat that has little general support.

3 - Popular discontent. Neptune exalted. The ability to destroy antiquated forms once the restrictions have been removed. Pluto in detriment, with general support, a savageness in eliminating the old order that may permanently scar the new.

4 - Platform. Jupiter exalted. A political and social agenda, embodied in guarantees to human rights that ensures a just and valued replacement of the old order. Mars in detriment. Promises, promises, promises and only to guarantee support with little possibility of implementation.

5 - Organization. The Moon exalted. Practical provisions for the needs of others in revolutionary times which ensures support and continued understanding. Mars in detriment. A concentration on the organization of power to clearly define authority often at the expense of higher principles.

6 - Attraction. The power of revolution in action to expand its support. Neptune exalted. An innate impressionability that transforms the fence-sitter into the committed. Saturn in detriment. Stubborn, and often fatal, rejectionism.

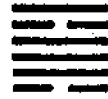
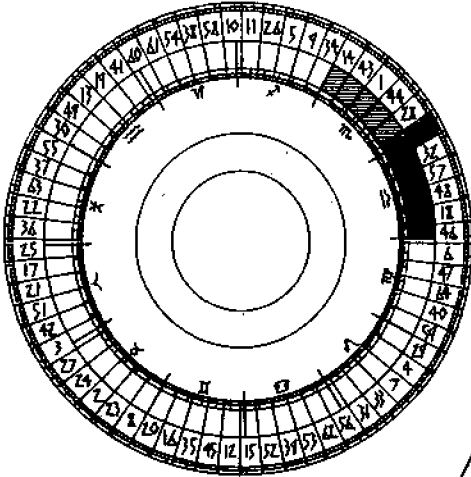

The Cauldron

26°22'30'' \triangle - 02°00'00'' M

The Lines

- 1-26°22'30'' - 27°18'45''
- 2-27°18'45'' - 28°15'00''
- 3-28°15'00'' - 29°11'15''
- 4-29°11'15'' - 00°07'30''
- 5-00°07'30'' - 01°03'45''
- 6-01°03'45'' - 02°00'00''

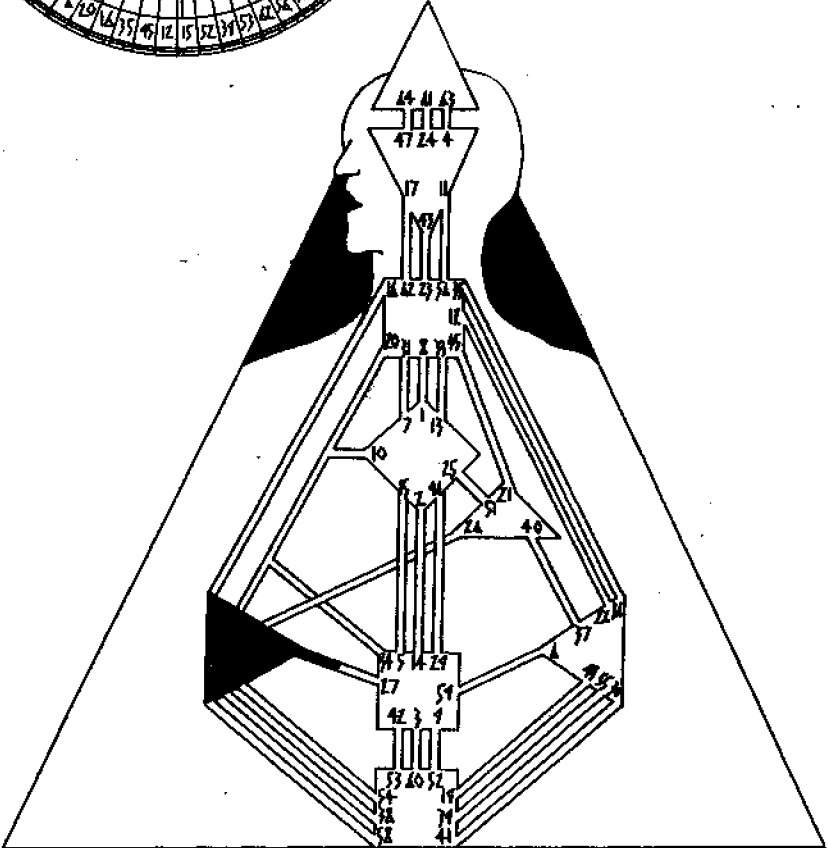

The Cauldron

Sign (Cusp Hexagram): Libra-Cardinal. Comparison Appreciation Evaluation
Scorpio-Fixed. Transcendence Sex Death Regeneration

Center: Splenic. Balance Cleansing Judgment

Biology: The Spleen and Lymph System

Gate: 50 The Cauldron

Harmonic Gate: 27 Nourishment

Channel: 50-27 Preservation. A design of custodianship

The value of historical continuity whose traditional values serve and enrich the present and the future.

The Lines

1 - The immigrant. Humbleness of origin that benefits rather than restricts destiny. Mars exalted. The desire to be effective and successful that builds on the most fundamental strengths while it refines its nature. Venus in detriment. A dissatisfaction with/or embarrassment with origins, that makes an obsession of refinement.

2 - Determination. The Sun exalted. The strength of purpose that can enjoy overcoming adversity to achieve its goals. Venus in detriment. A discomfort with adversity that may lead to determined withdrawal.

3 - Adaptability. The Moon exalted, that when unable to make it alone will naturally align itself with nurturing and protective forces. Mercury in detriment. A resentment when its natural mental gifts are ignored and is forced to curry favour in order to survive.

4 - Corruption. The lack of enriching values. Saturn exalted. The malefic gift of turning inferior values into material success. Given this difficult position, Saturn's exaltation is, that its actions are limited to selfishness and unsavouriness rather than criminality. Mars in detriment. With such energy and no traditional values, the worst can be expected.

5 - Consistency. When continuity has brought success, it should not be tampered with. Saturn exalted. The disciplined and natural conservatism to avoid unnecessary change. Mars in detriment. A perverse reaction to rebel against the methodology of one's very success.

6 - Leadership. Venus exalted. The gift in a position of power to maintain harmony even in severity. The Moon in detriment. An inherent moodiness, that in a position of power may at times alienate or offend and effect overall efficiency.

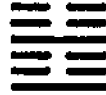
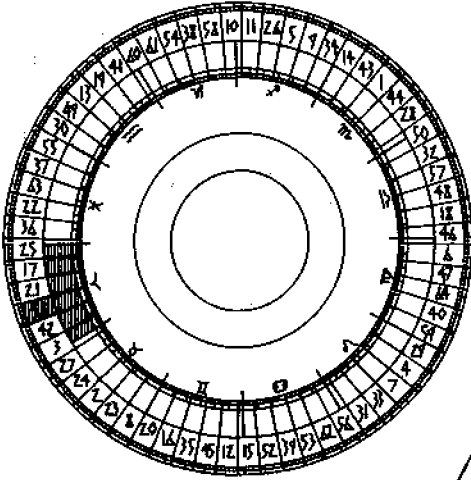

The Arousing

15°07'30'' - 20°45'00'' Y

The Lines

- 1-15°07'30'' - 16°03'45''
- 2-16°03'45'' - 17°00'00''
- 3-17°00'00'' - 17°56'15''
- 4-17°56'15'' - 18°52'30''
- 5-18°52'30'' - 19°48'45''
- 6-19°48'45'' - 20°45'00''

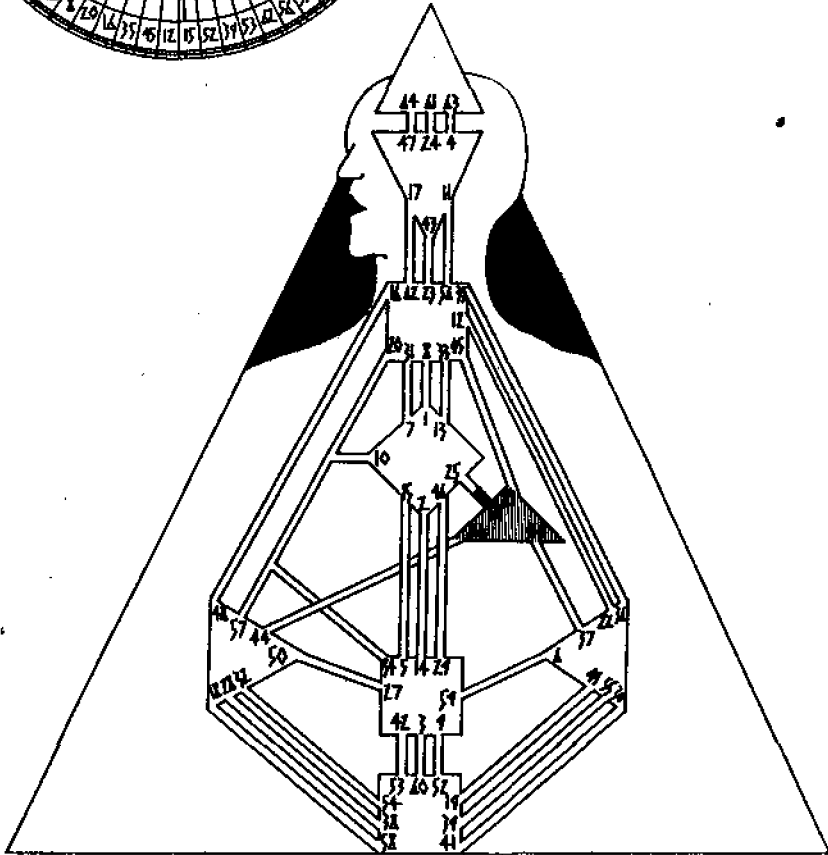

The Arousing

Sign: Aries-Cardinal. Desire Will Impulse Courage

Center: Heart. Ego Zeal Passion

Biology: The Thymus Gland

Gate: 51 The Arousing

Harmonic Gate: 25 Innocence

Channel: 51-25 Initiation. A design of needing to be first

The ability to respond to disorder and shock through recognition and adaptation.

The Lines

1 - Reference. The advantage of previous crisis experience. Pluto exalted. The gift of re-examination that is the foundation of preparedness. Venus in detriment. A tendency to emotional withdrawal after a shock.

2 - Withdrawal. Mars exalted. The recognition of the mechanics of shock that indicates when withdrawal is the only logical action. Mercury in detriment. Being too smart for one's own good and rejecting withdrawal in the vain belief that one can outsmart natural forces.

3 - Adaptation. The Sun exalted. The life-sustaining awareness that thinks on its feet and thus creates opportunities. Jupiter in detriment. The destabilization that occurs when one's field of normal activity is radically and unpredictably disturbed, where the tendency is withdrawal rather than adaptation.

4 - Limitation. Uranus exalted. A pure inventiveness and sometimes genius to find some opportunity even in the midst of the most devastating shocks. Mercury in detriment. A reasoned make-do mentality that is ineffectual in times of severe shock.

5 - Symmetry. The Sun exalted. Perfected illumination that in grasping the nature of the shock, can transform its normal patterns into a symmetrical adaptation that rides the shock and avoids its devastation. Mars in detriment. A tendency in seeking the core, to harmonize with one shock only to be overwhelmed by the next.

6 - Separation. The Sun exalted. In times of crisis when all those around are confused and in disorder, the ability not to succumb to the panic but to have the will and vitality to survive it alone. Pluto in detriment. Curiously, the same gift, but one by its attitude that invites disapproval that in the extreme may even prevent a successful separation.

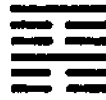
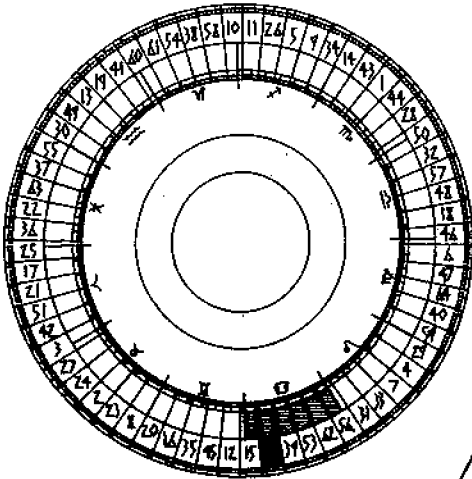

Keeping Still

03°52'30'' - 09°30'00'' $\frac{9}{6}$

The Lines

- 1-03°52'30'' - 04°48'45''
- 2-04°48'45'' - 05°45'00''
- 3-05°45'00'' - 06°41'15''
- 4-06°41'15'' - 07°37'30''
- 5-07°37'30'' - 08°33'45''
- 6-08°33'45'' - 09°30'00''

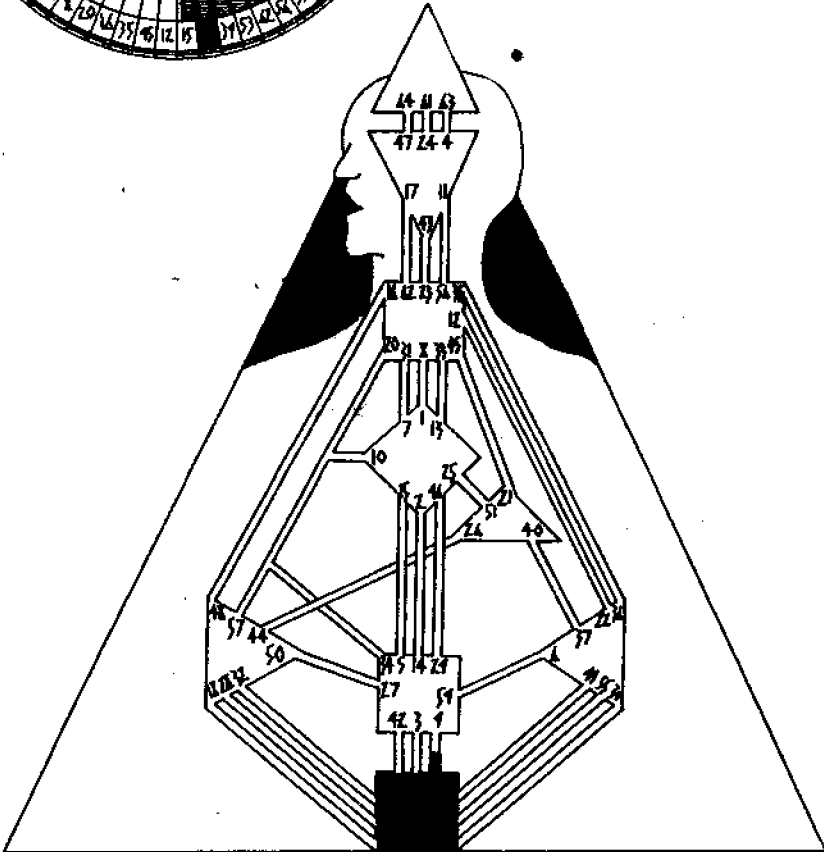

Keeping Still

Sign: Cancer-Cardinal. Receptivity Sensitivity Home

Center: The Base of the Spine. Assertion Energy Evolution

Biology: The Adrenal Glands

Gate: 52 Keeping Still

Harmonic Gate: 9 Taming Power of the Small

Channel: 52-9 Concentration. A design of determination

Temporary and self-imposed inaction for the benefit of assessment.

The Lines

1 - Think before you speak. The Earth exalted. The pause that is so profound that it leads to silence. Mars in detriment. Speaking first and living with the consequences afterwards.

2 - Concern. Venus exalted. The pause that is initiated to benefit others. Mars in detriment. A selfish and abrupt pause that may endanger others unnecessarily.

3 - Controls. External enforcement of inaction. Saturn exalted. The ability by its very nature to understand restraint with the potential in acceptance, to use the period to redefine strategies. Venus in detriment. A deep dissatisfaction with controls that disturb tranquillity, leads to emotional withdrawal and affects vision.

4 - Self-discipline. Saturn exalted. Perfected self-discipline and restraint that deals easily and wisely with impulsive temptations. Jupiter in detriment. Though responsive to the need of a principled control based on the understanding of conditions, there is a tendency due to its natural expansiveness, to doubt and restlessness.

5 - Explanation. In times of inaction, the often important ability, to explain one's position. The Earth exalted. The often terse but exceedingly accurate statement. Pluto in detriment. A convoluted whose enigmatic nature is normally misunderstood with unpredictable circumstances.

6 - Peacefulness. Venus exalted. A harmonic and balanced attunement that is at ease regardless of the situation. Neptune in detriment. Delusion as a substitute for genuine tranquillity. Given the positive nature of this position, the delusion may be just as effective as the 'real thing'.



Development

15°07'30'' - 20°45'00'' ☳

The Lines

- 1-15°07'30'' - 16°03'45''
- 2-16°03'45'' - 17°00'00''
- 3-17°00'00'' - 17°56'15''
- 4-17°56'15'' - 18°52'30''
- 5-18°52'30'' - 19°48'45''
- 6-19°48'45'' - 20°45'00''

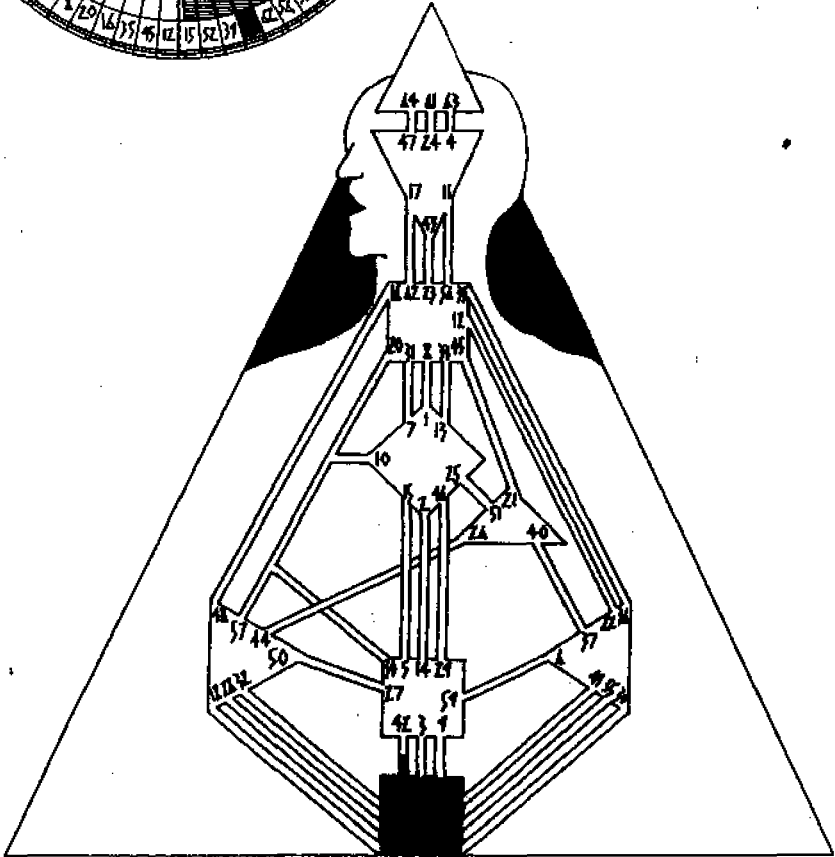
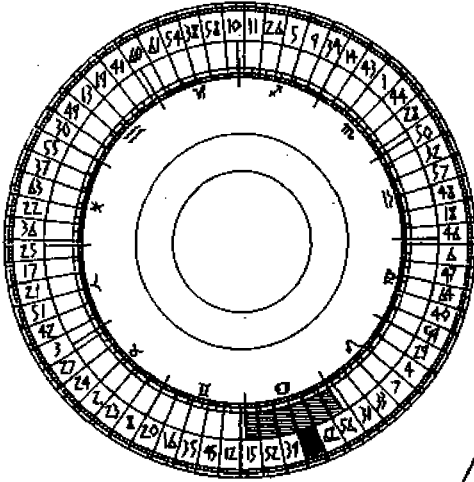

Development

Sign: Cancer-Cardinal. Receptivity Sensitivity Home

Center: The Base of the Spine. Assertion Energy Evolution

Biology: The Adrenal Glands

Gate: 53 Development **Harmonic Gate:** 42 Increase

Channel: 53-42 Maturation. A design of balanced development

Development as a structured progression that is both steadfast and enduring.

The Lines

1 - Accumulation. Neptune exalted. The dissolution of old forms but not at the expense of valued components that will be retained and transformed. Venus in detriment. Development hampered by criticism and the tendency to withdraw rather than make use of these experiences.

2 - Momentum. Success breeds success. The Moon exalted. The protection of early success nurtures further achievement. Mars in detriment. A tendency with early success to haste and imprudent action.

3 - Practicality. The Moon exalted. In its most natural position, the concentration on avoiding conflict to ensure protection and continued development. Mars in detriment. The unconscious provoking of conflict that logically threatens security and development.

4 - Assuredness. The Moon exalted. The ability to maintain the strength of one's individuality in complex and often awkward situations, that ensure continued security and development. Venus in detriment. The persistent difficulty with embarrassing or awkward situations where normal emotional reactions may prove detrimental.

5 - Assertion. Neptune exalted. The underlying and often psychic recognition of the intrinsic values of development, that even in periods of isolation, has the assertiveness to maintain direction. Its very power garners continued support even from those who are basically opposed. The Earth in detriment. An over-assertiveness, that rather than applied to maintaining support in the face of opposition and isolation, may actually strengthen the opposing forces by its attitude.

6 - Phasing. The Moon exalted. The successful utilization of the completion of a stage in development, that by its evident success and value can be used as an example to attract support for the next stage. Pluto in detriment. A tendency in this position, to hide success, in the perverse fear that the success will either create excessive demands or supporters of the original process will end their support upon completion.

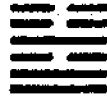
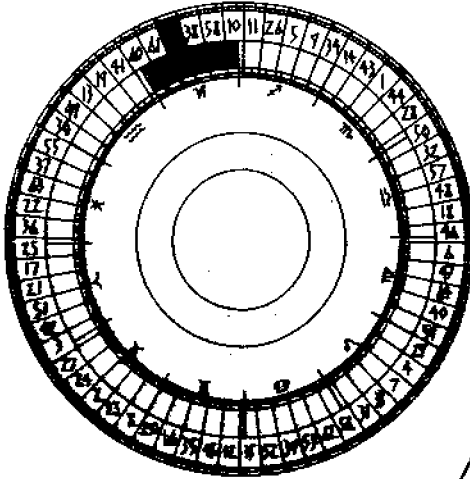

The Marrying Maiden

15°07'30'' - 20°45'00'' V

The Lines

- 1-15°07'30'' - 16°03'45''
- 2-16°03'45'' - 17°00'00''
- 3-17°00'00'' - 17°56'15''
- 4-17°56'15'' - 18°52'30''
- 5-18°52'30'' - 19°48'45''
- 6-19°48'45'' - 20°45'00''

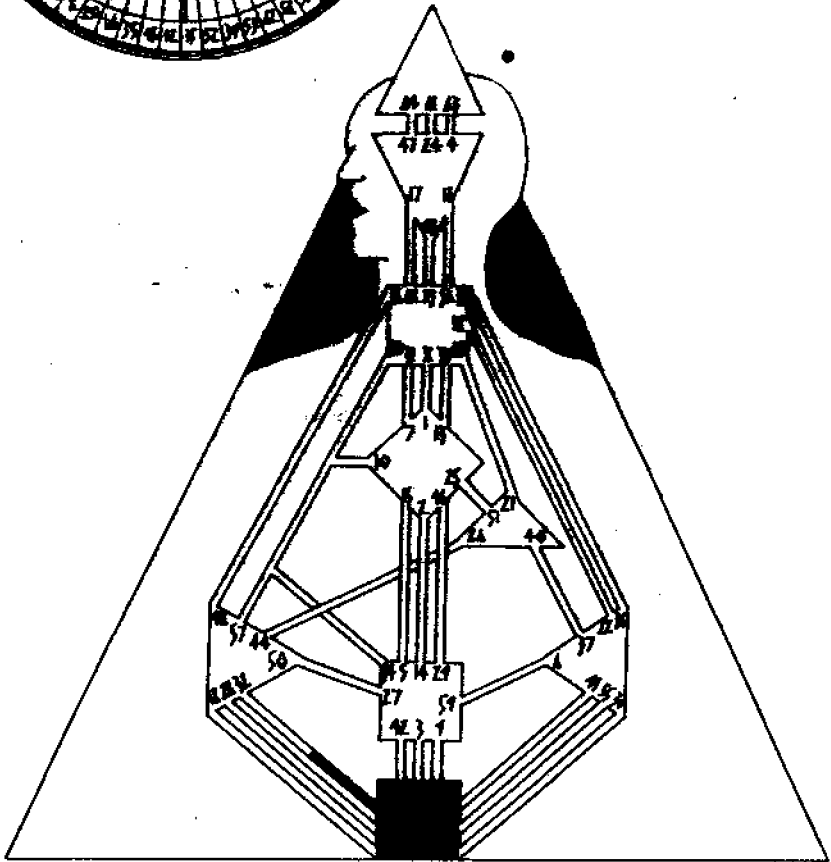

The Marrying Maiden

Sign: Capricorn-Cardinal. Ambition Government Status

Center: The Base of the Spine. Assertion Energy Evolution

Biology: The Adrenal Glands

Gate: 54 The Marrying Maiden **Harmonic Gate:** 32 Duration

Channel: 54-32 Transformation. A design of being driven

Interaction in its mundane social context but also one's mystical and cosmic relationships.

The Lines

1 - Influence. Pluto exalted. The ability to achieve influence through secret relationships, anywhere from the private adviser to the Satanist. Venus in detriment. A socially misguided insistence on formal recognition of a relationship, that in terms of influence, will diminish its power.

2 - Discretion. Saturn exalted. The wisdom once a relationship is formally recognized to restrain the temptation to take advantage of past informal interactions. Mars in detriment. Recognition, in the formal sense, seen as a licence to take advantage of informal knowledge. A lack of loyalty.

3 - Covert interaction. Pluto exalted. The ability when stymied in formal relationships to use secret or purely informal channels, when it is the only resort. Venus in detriment. The insistence that formal channels, no matter how frustrating, can be overcome by the power of attraction.

4 - Enlightenment/Endarkenment. Here, in this most mystical of positions, there is neither an exaltation nor a detriment, for in truth, they are the same. The Alpha and Omega. The end and the beginning. There is no description possible. Each planet will manifest this energy uniquely with absolutely no guarantee that its effects will even be perceived. However, the potential is always there.

5 - Magnanimity. The Sun exalted. The natural authority and actualizing spirit, that in a position of power, can have genuine and fruitful relationships with the less advantaged. (As long as they are in service and make no demands.)

6 - Selectivity. Saturn exalted. The ingrained responsibility, in terms of maintaining security and personal identity that will naturally restrict its relationships to ones that are mutually beneficial. Jupiter in detriment. A generally benefic and expansive nature that assumes that it can instill, what is otherwise missing in its partners. A waste of energy.

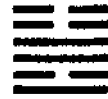
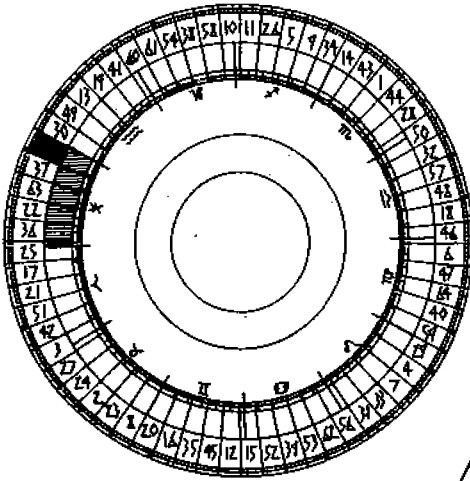

Abundance

00°07'30'' - 05°45'00'' ☿

The Lines

- 1-00°07'30'' - 01°03'45''
- 2-01°03'45'' - 02°00'00''
- 3-02°00'00'' - 02°56'15''
- 4-02°56'15'' - 03°52'30''
- 5-03°52'30'' - 04°48'45''
- 6-04°48'45'' - 05°45'00''

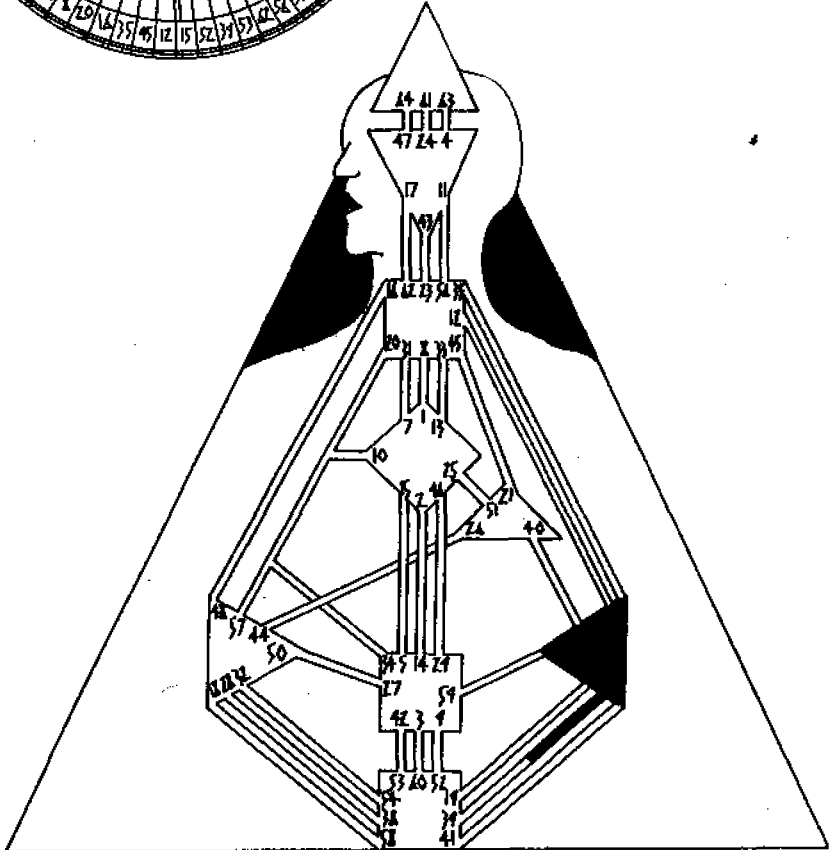

Abundance

Sign: Pisces-Mutable. Openness Devotion Conflict

Center: Solar Plexus. Aspiration Sensitivity Emotion

Biology: The Kidney and Pancreas

Gate: 55 Abundance

Harmonic Gate: 39 Obstruction

Channel: 55-39 Emoting. A design of moodiness

Abundance is strictly a question of spirit.

The Lines

1 - Co-operation. Jupiter exalted. The expansion of activity through co-operation with powerful forces through principled actions that guarantee continued support and engender prosperity. Venus in detriment. The concentration on harmonic relationships with powerful forces that provide for continuity but not necessarily advancement.

2 - Distrust. Abundance hampered by slander or gossip. Venus exalted. The gift of being able to penetrate to the center that may demonstrate effectively through its relating talents, that its trustfulness is genuine. The Earth in detriment. The direct challenge to the slanderers who will always have the advantage of quoting the Bard: 'Methinks he doth protest too much.' Only continued example can overcome distrust.

3 - Innocence. Here, 'I was only following orders', is a genuine defence. Saturn exalted. When the form is correct and attempts at actualization have been disciplined and within guidelines, failure cannot be personally attributed. Mars in detriment, where a struggle against conformity or individual initiative can bring a superior to ruin while safely hiding behind his shield.

4 - Assimilation. Jupiter exalted. The establishment of a framework that balances principles with energy and leads inevitably to expansion and prosperity. Mars in detriment. Boundless energy that knows no restraint.

5 - Growth. Uranus exalted. The unusual ability in a position of power to accept advice and transform it innovatively. This gift in a position of power allows one to continue to lead rather than being perceived as being led. The Sun in detriment. An integrative openness that in its broad acceptance of advice may be eventually eclipsed.

6 - Selfishness. Saturn exalted. Acquisition obsession that though alienating, is still indirectly beneficial materially to others. The Moon in detriment. Where the material abundance exists, but no one gets to share its light. The 'no Moon' phase.

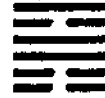

The Wanderer

26°22'30'' $\overline{26}$ - 02°00'00'' $\overline{01}$

The Lines

- 1-26°22'30'' - 27°18'45''
- 2-27°18'45'' - 28°15'00''
- 3-28°15'00'' - 29°11'15''
- 4-29°11'15'' - 00°07'30''
- 5-00°07'30'' - 01°03'45''
- 6-01°03'45'' - 02°00'00''

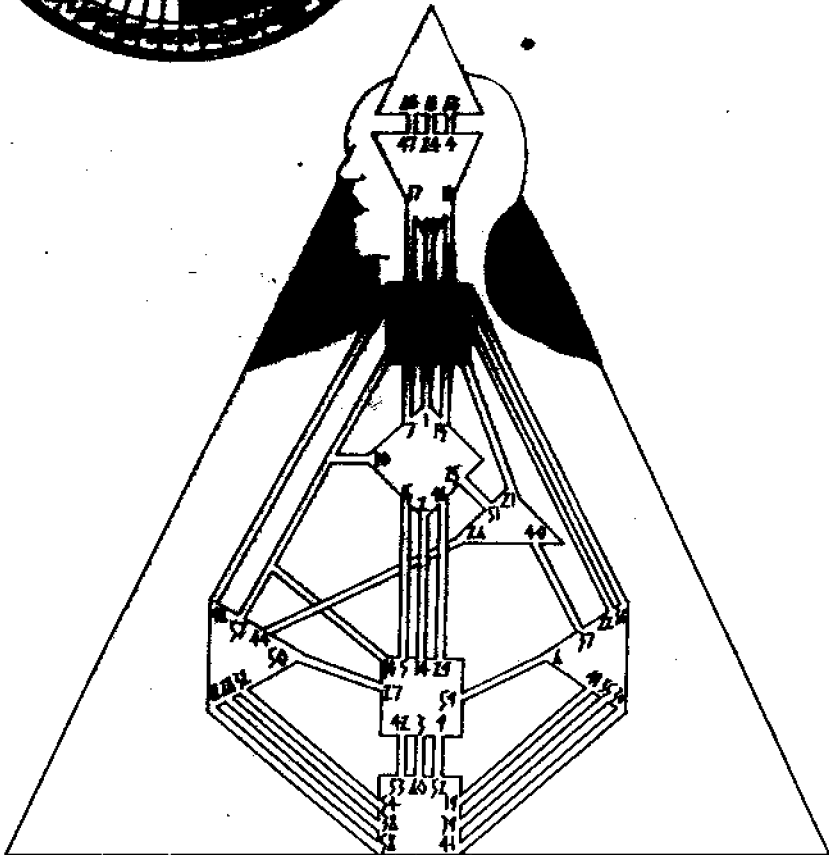
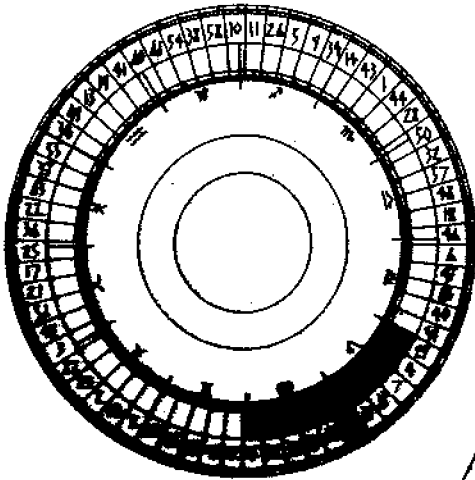

The Wanderer

Sign (Cusp Hexagram): Cancer-Cardinal. Receptivity Sensitivity Home
Leo-Fixed. Self-expression Pleasure Authority

Center: Throat. Action Metamorphosis Unfolding

Biology: The Thyroid and Parathyroid Glands

Gate: 56 The Wanderer

Harmonic Gate: 11 Peace

Channel: 56-11 Curiosity. A design of a searcher

Stability through movement. The perpetuation of continuity through the linking of short term activity.

The Lines

1 - Quality. The Moon exalted. The practical sense that even short term activities should be of value. Mars in detriment. The ego drive to make an impression that will misuse energy in trivial pursuits.

2 - Linkage. Uranus exalted. Isolated genius that will eventually find continuity through recognition and support. The Moon in detriment. A superficiality which collapses under recognition and is eventually forced to move on.

3 - Alienation. Determined self-sufficiency. The Sun exalted. A will and egoism that often proves overbearing and guarantees continued isolation. Here, this is acceptable given the Sun's intrinsic vitality. Venus in detriment. The reversed aesthetic that offends others, ensures isolation, and eliminates support.

4 - Expediency. The Moon exalted. The perfection of the superficial personality, that can mask, when essential, its true feelings to secure protection. Mercury in detriment. Expedient behaviour whose price is a constant stressful alertness and nervous anxiety in fear of losing what has been gained.

5 - Attracting attention. Uranus exalted. Unusualness, innovation and sometimes genius as guarantees of eventually attracting attention and support. Mars in detriment. All too often the tendency to attract attention that is self-defeating in its effects.

6 - Caution. The Sun exalted. The prudence, when linkage has been achieved, to honour its new commitments in order to secure its footing. Pluto in detriment. The profound unconscious wanderer, where external yearning for acceptance will unconsciously release the exact energy that creates rejection. A difficult role, where the self is unknown and not recognized with predictable results.

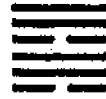
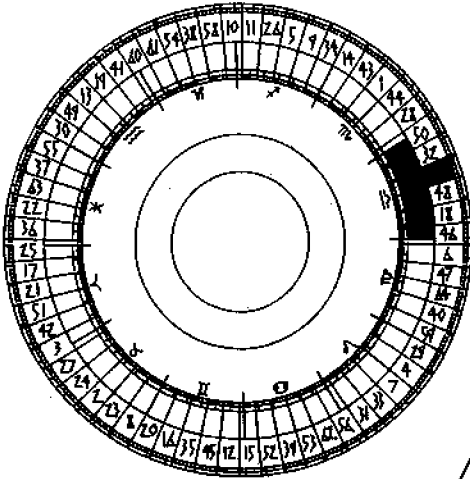

The Gentle

15°07'30'' - 20°45'00'' ☴

The Lines

- 1-15°07'30'' - 16°03'45''
- 2-16°03'45'' - 17°00'00''
- 3-17°00'00'' - 17°56'15''
- 4-17°56'15'' - 18°52'30''
- 5-18°52'30'' - 19°48'45''
- 6-19°48'45'' - 20°45'00''

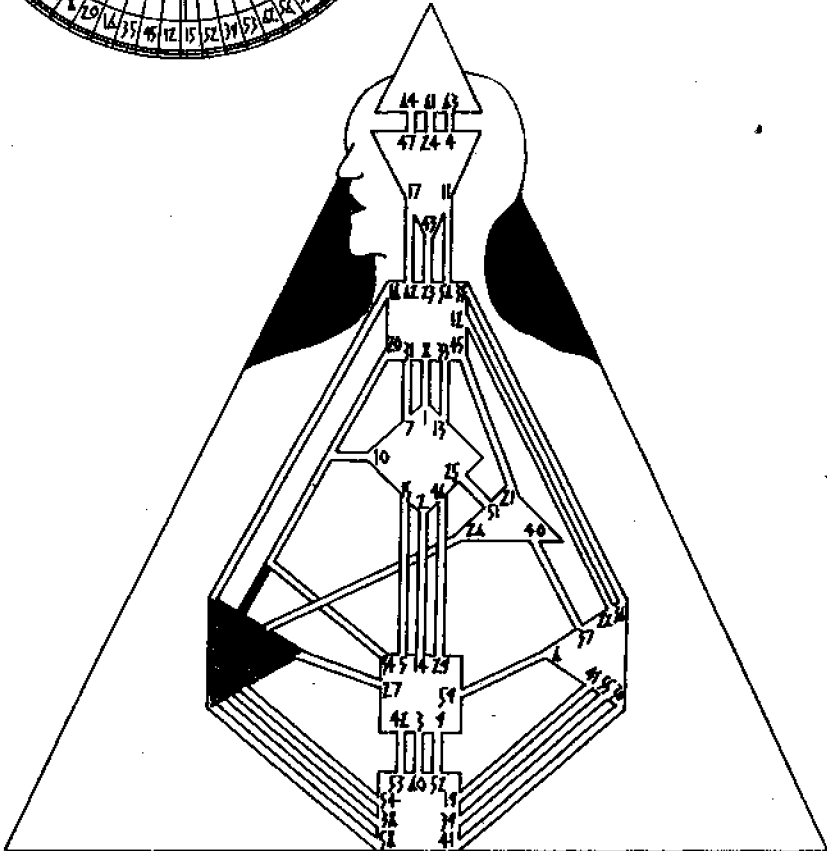

The Gentle

Sign: Libra-Cardinal. Comparison Appreciation Evaluation

Center: Splenic. Balance Cleansing Judgment

Biology: The Spleen and Lymph System

Gate: 57 The Gentle

Harmonic Gates: 20 Contemplation

10 Treading

34 The Power of the Great

Channels: 57-20 The Brain Wave. A design of awareness

57-10 Perfected Form. A design of survival

57-34 Power. A design of an archetype

The extraordinary power of clarity.

The Lines

1 - Confusion. Venus exalted. The gift of penetrating to the inner meaning that ensures timely action. The Moon in detriment, where feelings are no substitute for clarity and can lead to indecision.

2 - Cleansing. The clarity to establish proper values and ideals must be accompanied by resolute determination to maintain them. Venus exalted. Perfected cleansing through inner realization. The Moon in detriment. A superficial cleansing that tends to hide the dirt underneath the carpet.

3 - Acuteness. There is no detriment. Mercury exalted. The perfected intelligence, where clarity eliminates doubt and ensures manifestation.

4 - The director. Venus exalted. The mastery of relationships that through clarity can maximize productivity while the sensitivity to interrelationships will ensure harmony. Mars in detriment. A tendency given this position to be dictatorial rather than directorial.

5 - Progression. Pluto exalted. The natural ability to establish new forms while maintaining the powers of re-evaluation and reexamination. This provides the clarity to examine the data and assess the process. The Moon in detriment. The tendency to keep on keeping on, that can end up as a misguided missile.

6 - Utilization. Uranus exalted. The acceptance that clarity is a double-edged sword. There are situations where understanding cannot lead to rectification. Here, Uranus' innovative quality can generally make the best out of an otherwise difficult but rarely permanent situation. Mars in detriment. When clarity points to a problem one is unable because of circumstances to solve, a tendency to anger and frustration that provokes inevitably futile action.

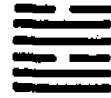
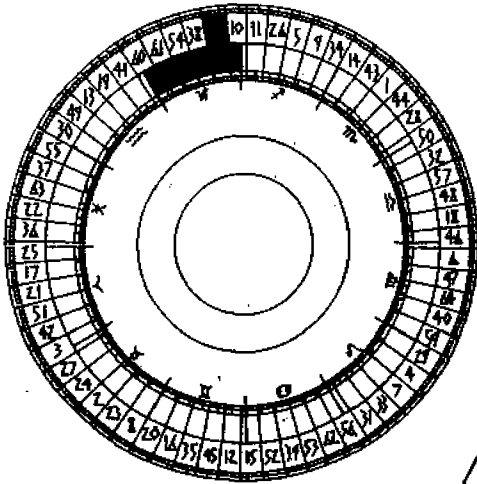

The Joyous

03°52'30'' - 09°30'00'' ㄚ

The Lines

- 1-03°52'30'' - 04°48'45''
- 2-04°48'45'' - 05°45'00''
- 3-05°45'00'' - 06°41'15''
- 4-06°41'15'' - 07°37'30''
- 5-07°37'30'' - 08°33'45''
- 6-08°33'45'' - 09°30'00''

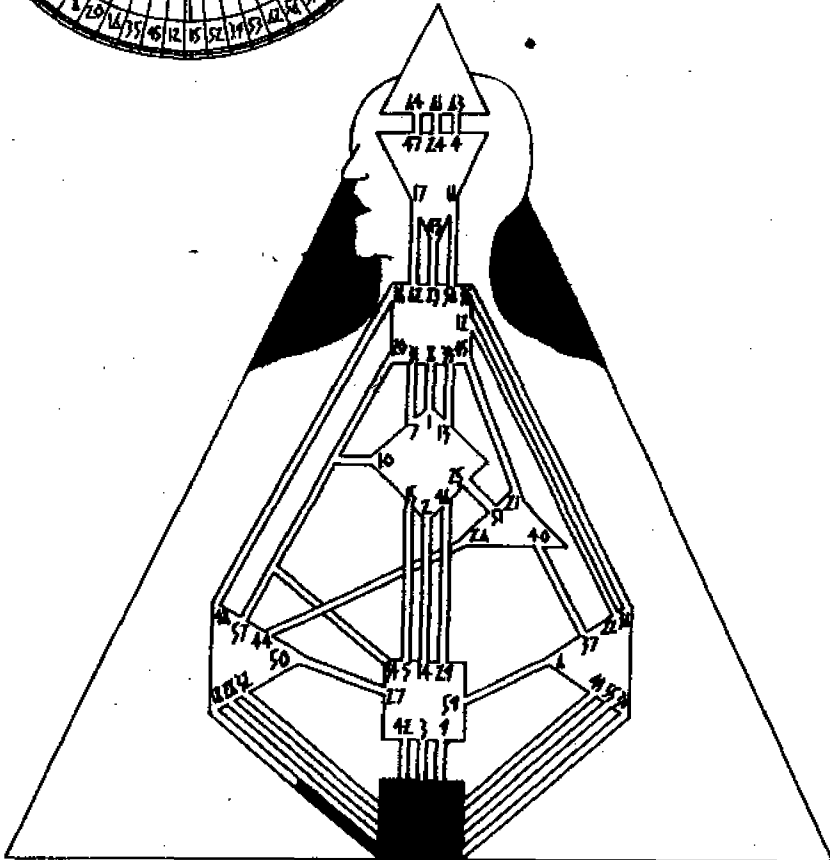

The Joyous

Sign: Capricorn-Cardinal. Ambition Government Status

Center: The Base of the Spine. Assertion Energy Evolution

Biology: The Adrenal Glands

Gate: 58 The Joyous

Harmonic Gate: 18 Work on What Has Been Spoilt

Channel: 58-18 Judgment. A design of insatiability

Stimulation is the key to joy.

The Lines

1 - Love of life. Venus exalted. The very stimulation of the world is the basis of an aesthetic appreciation of its beauty and wonder. Alone or shared with others this profound inner realization is the key for a joyous harmony with the process of being. The Moon in detriment. The Moon has its phases, its moods, that will limit joy to an intermittent and cyclical experience.

2 - Perversion. There is no exaltation. Uranus in detriment. A genius for perverse stimulation that afflicts oneself and others by promoting degeneracy and reducing joy to indulgence and decadence.

3 - Electricity. Uranus exalted. The individual whose electric vitality creates its own stimulation and is not dependent on others. Mars in detriment. The quality of fire is dependent on its fuel and subject to its influence, good or bad.

4 - Focusing. Pluto exalted. A natural specialization that when confronted with a multiplicity of stimulations will have no inner difficulty in focusing on the appropriate influence. Neptune in detriment. An impressionability that becomes confused when confronted with a multiplicity of stimulations and in trying to accommodate all of it, becomes unstable.

5 - Defense. The Moon exalted. The natural and practical instinct to protect oneself regardless of temptations. The Sun exalted. The assumption that the best defense is a good offense, that might allow strength of character to enjoy questionable stimulus without succumbing to it.

6 - Carried away. The Moon exalted. The tendency to practicality that while thoroughly enjoying external stimulation has the instinct to draw back when its independent integrity is threatened. Mercury in detriment. When its basic intelligence is effectively stimulated, its natural desire for attunement will lead it to identify so strongly with the stimulation that it is at risk of losing its identity.

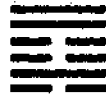
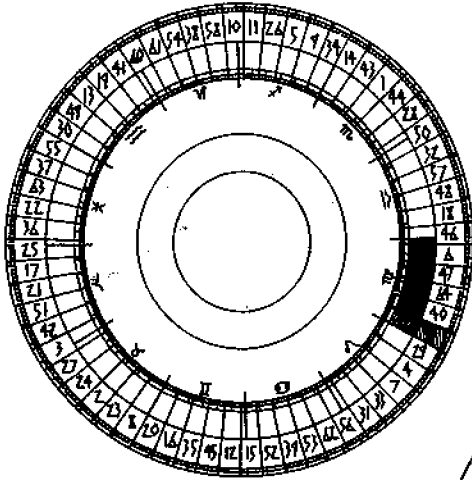

Dispersion

00°07'30'' - 05°45'00'' 112

The Lines

- 1-00°07'30'' - 01°03'45''
- 2-01°03'45'' - 02°00'00''
- 3-02°00'00'' - 02°56'15''
- 4-02°56'15'' - 03°52'30''
- 5-03°52'30'' - 04°48'45''
- 6-04°48'45'' - 05°45'00''

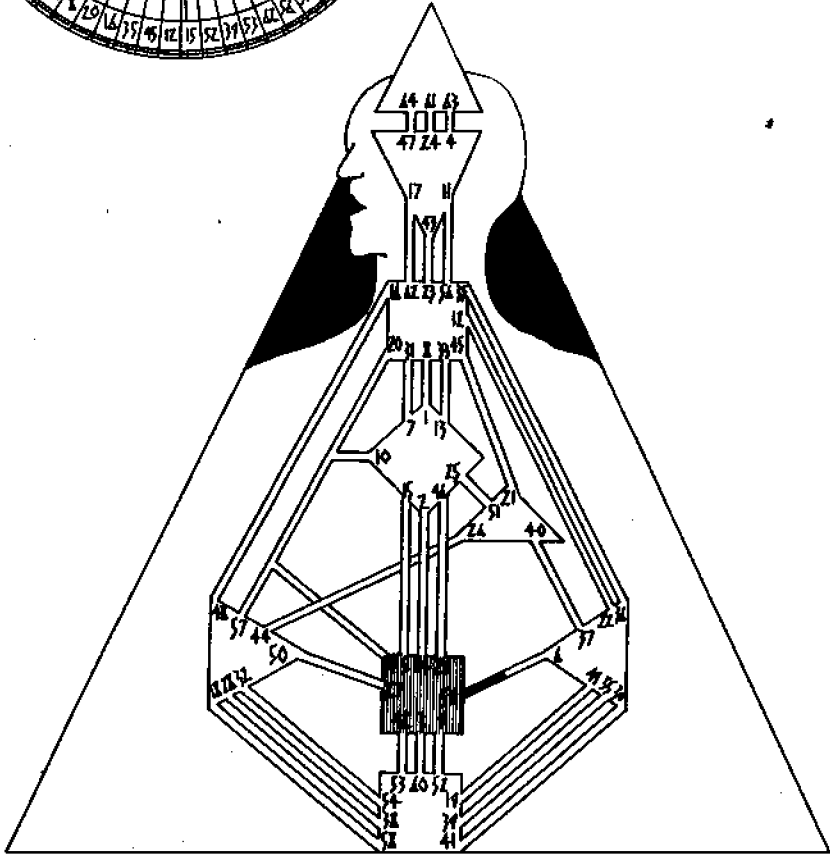

Dispersion

Sign: Virgo-Mutable. Mental detail Service Judgmentation

Center: Sacral. Maturation Reproduction Sexuality

Biology: The Ovaries and the Testes

Gate: 59 Dispersion

Harmonic Gate: 6 Conflict

Channel: 59-6 Mating. A design focused on reproduction

The ability to break down barriers to achieve union.

The Lines

1 - The preemptive strike. The Sun exalted. The authority and vitality that in understanding purpose and direction can recognize and eliminate barriers before they become impregnable. Mercury in detriment. In this position, the ability and intelligence to recognize, but a deep indecisiveness about how and when to act.

2 - Shyness. Self-imposed barriers. Uranus exalted. A preferred and natural separateness that protects against the inevitable instability engendered by union. Pluto in detriment. A calculated shyness, rooted in deep psychological barriers, that even in dynamic individuals will always restrict interaction.

3 - Openness. Saturn exalted, where the search for identity and security can only be achieved through the dropping of barriers, in order to define oneself through union. Mars in detriment. Where openness is transformed into promiscuity and its attendant problems.

4 - Brotherhood/Sisterhood. Venus exalted. The dropping of barriers to union to establish a universal union. Mercury in detriment. An intellectual understanding that is rarely put into action.

5 - The Femme Fatale or Casanova. The Sun exalted. The power to use love to break down any barrier. Given the Sun's 'lightness' there is no negative connotation inherent in this description. Uranus in detriment, where the negative potential of this power becomes evident. The Gigolo, the adventuress.

6 - The One Night Stand. The tendency based on personality or circumstances to accept only temporary unions that may be otherwise impossible or dangerous to continue. Venus exalted. The perfected relationship whether for a moment or an eternity. Mercury in detriment. The basic drive to move on, that seeks impermanency as a matter of course and not in response to circumstances.

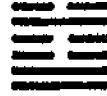
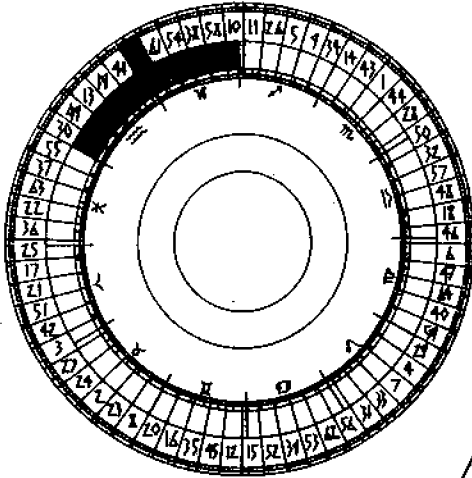

Limitation

26°22'30" N - 02°00'00" W

The Lines

1-26°22'30" - 27°18'45"
 2-27°18'45" - 28°15'00"
 3-28°15'00" - 29°11'15"
 4-29°11'15" - 00°07'30"
 5-00°07'30" - 01°03'45"
 6-01°03'45" - 02°00'00"

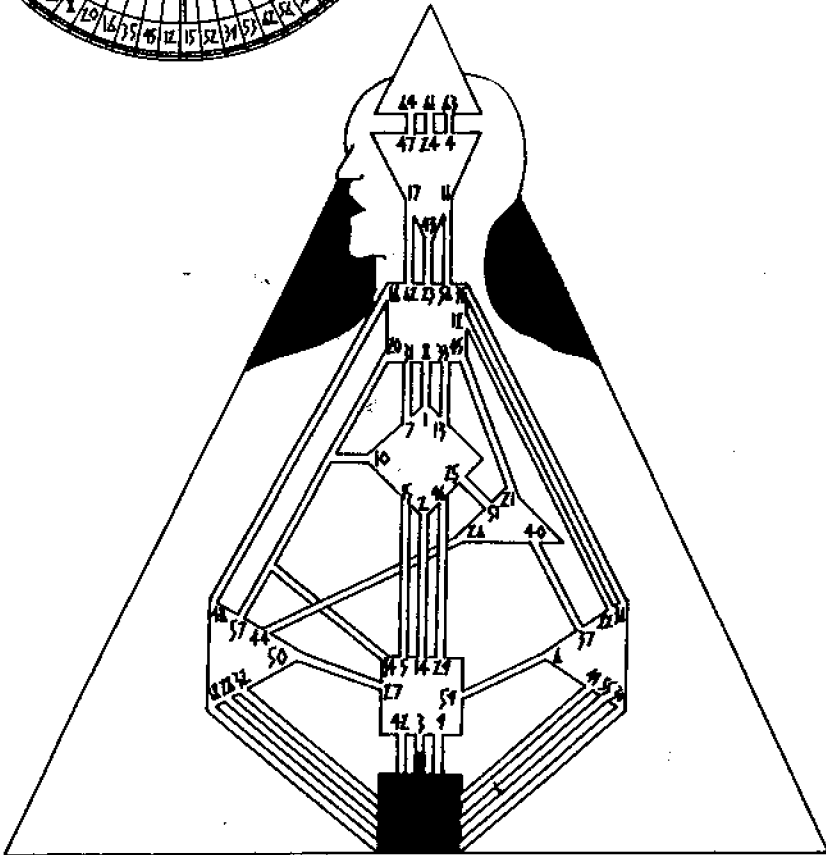

Limitation

Sign (Cusp Hex.): Capricorn-Cardinal. Ambition Government
Status

Aquarius-Fixed. Science Humanitarianism Music
Center: The Base of the Spine. Assertion Energy Evolution

Biology: The Adrenal Glands

Gate: 60 Limitation Harmonic Gate: 3 Difficulty at the
Beginning

Channel: 60-3 Mutation. Energy that fluctuates and
initiates.

The acceptance of limitation is the first step in
transcendence.

The Lines

1 - Acceptance. Venus exalted. The ability to maintain inner
harmony when confronted by external limitations. Mercury in
detriment. The drive for diversity, that when limited can
become restless and agitated.

2 - Decisiveness. Saturn exalted. The understanding of the
nature of limitation, to accept its restraints when neces-
sary and thus be able to take advantage of opportunities
when they arise. The Earth in detriment. An adaptation to
restraint that becomes habitual and maintains the nature of
the limitation even when it no longer exists.

3 - Conservatism. Saturn exalted. Enlightened self-interest,
that naturally handles restrictions and limitations ensuring
identity and security. Mars in detriment. Ego gratifying
self-interest that ignores limitations and suffers predict-
ably.

4 - Resourcefulness. Mercury exalted. The reasoned and in-
telligent maximization of potential within limitations.
Venus in detriment. A tendency in times of limitation to
seek the inner meaning of the restriction rather than using
its gifts to find a harmonic application within the limi-
tation. The former leads to withdrawal and the latter to
transcendence.

5 - Leadership. Neptune exalted. The awareness that the
destruction of the old limitations simply creates new ones.
This results in behavioural patterns that demonstrate this
understanding through actions and enhances leadership po-
tential. Jupiter in detriment. Where the natural desire for
expansion, when limitations are essential, creates confusion
from the top.

6 - Rigidity. Uranus exalted. The intuitive intellect to
recognize when absolute rigidity is essential but with in-
novative applications to lessen its severity. Mercury in
detriment. The dogmatic, principled and carefully reasoned
understanding that is uncompromizing in its severity and
often coldly brutal in operation.



Inner Truth

20°45'00'' - 26°22'30'' ∇

The Lines

- 1-20°45'00'' - 21°41'15''
- 2-21°41'15'' - 22°37'30''
- 3-22°37'30'' - 23°33'45''
- 4-23°33'45'' - 24°30'00''
- 5-24°30'00'' - 25°26'15''
- 6-25°26'15'' - 26°22'30''

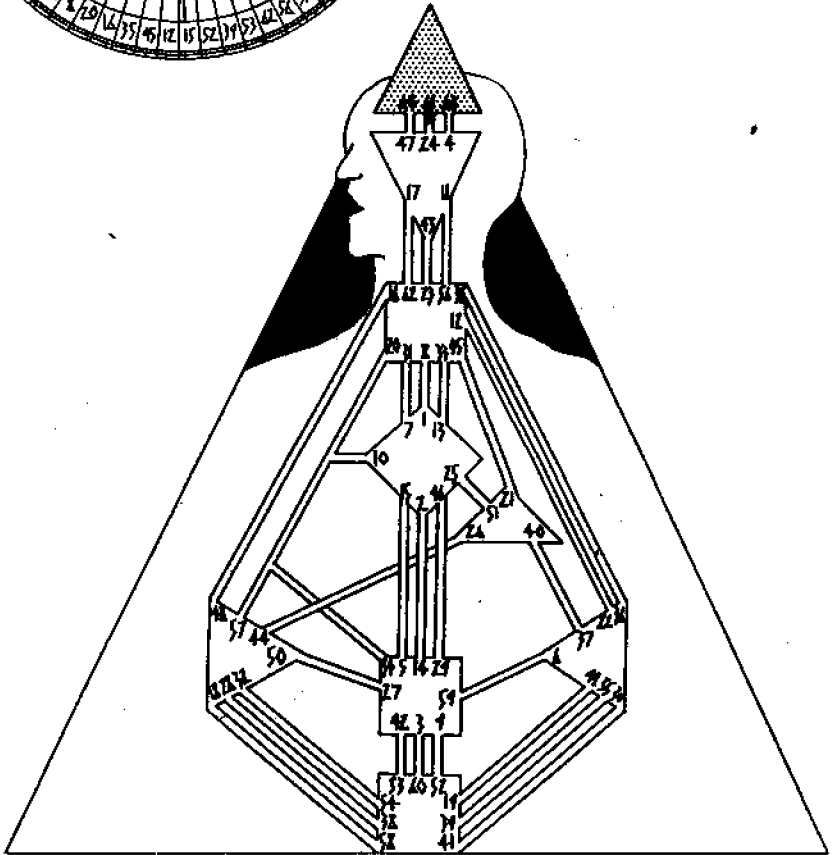
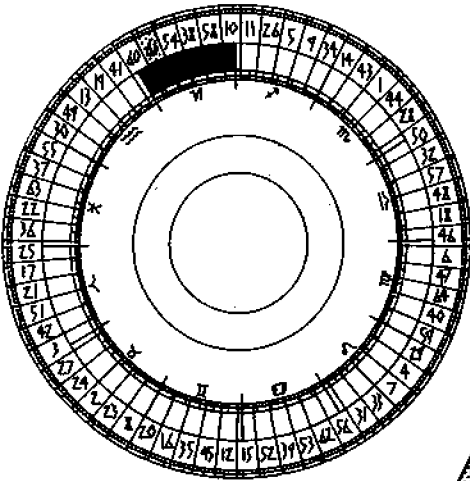

Inner Truth

Sign: Capricorn-Cardinal. Ambition Government Status

Center: The Head Center. Inspiration Initiation Undergoing

Biology: The Pineal Gland

Gate: 61 Inner Truth

Harmonic Gate: 24 Returning

Channel: 61-24 Awareness. A design of a thinker

The awareness of universal underlying principles.

The Lines

1 - Occult knowledge. Neptune exalted. A natural psychic awareness that empowers principles of universalization. Venus in detriment. Where a reliance on secret knowledge increasingly demands ascetic withdrawal and leads eventually to obscurity.

2 - Natural brilliance. The Moon exalted, and so gifted by this position a far-reaching, a nourishing influence, free of guile and powerfully attractive. Mars in detriment. That in early recognition of its influence becomes ego obsessed with maximizing its effects.

3 - Interdependence. It is exceedingly difficult for truth to stand alone. The Moon exalted. The ability to establish relationships for the actualization of truths, and through their nurturing and protective power to ensure a stable environment in which they can continue to grow. Mars in detriment. With an abundance of energy and in possession of a truth, the tendency to leave others behind or be crushed by their resistance.

4 - Research. Saturn exalted. The capacity of concentration to explore the depths of inner truth and maximize its application to fundamental principles. Jupiter in detriment. Where the tendency to expansion and integration leads to involving others in the research and may end in a diversity of confusing applications.

5 - Influence. Saturn exalted. The enlightened Father figure whose recognized wisdom and powerful assertion can mold a generation by its influence. Mars in detriment. A tendency in power to want to enforce compliance to ensure lasting influence.

6 - Appeal. Pluto exalted. The profound attunement to the collectivity that can lure the public to a truth. Mars in detriment. A reliance on shop-worn clichés and slogans that may be new in their level of energy but inevitably fall on deaf ears.

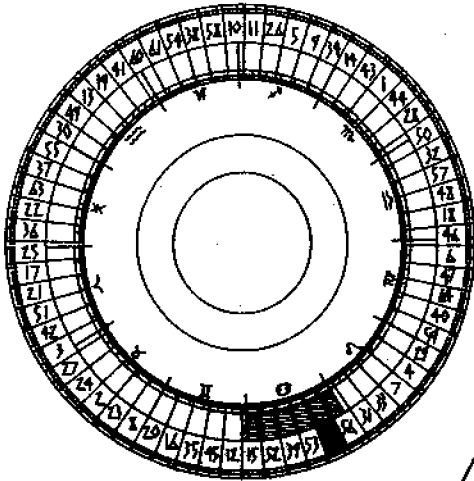

Preponderance of the Small

20°45'00'' - 26°22'30'' ☰

The Lines

- 1-20°45'00'' - 21°41'15''
- 2-21°41'15'' - 22°37'30''
- 3-22°37'30'' - 23°33'45''
- 4-23°33'45'' - 24°30'00''
- 5-24°30'00'' - 25°26'15''
- 6-25°26'15'' - 26°22'30''

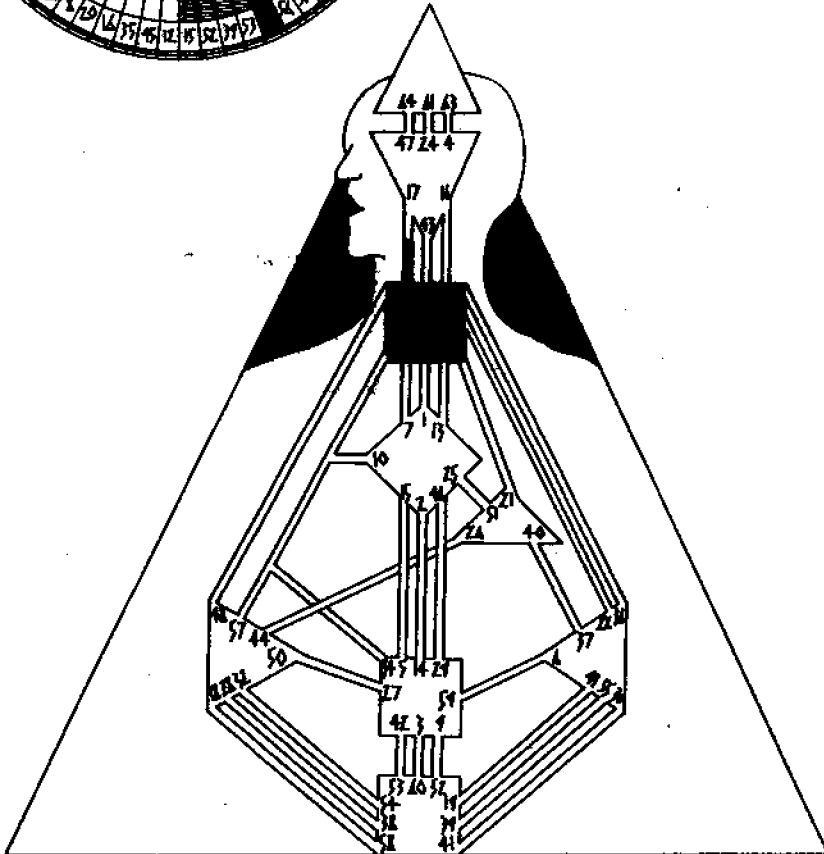

Preponderance of the Small

Sign: Cancer-Cardinal. Receptivity Sensitivity Home

Center: The Throat Center. Action Metamorphosis Unfolding

Biology: The Thyroid and Parathyroid Glands

Gate: 62 Preponderance of the Small

Harmonic Gate: 17 Following

Channel: 62-17 Acceptance. A design of an organizational being

Caution, patience and detail produce excellence out of limitation.

The Lines

1 - Routine. Neptune exalted. The ability to transcend the boredom of routine through a rich and daring fantasy life. Mars in detriment. Rebellion and its enormous waste of energy.

2 - Restraint. Saturn exalted. The innate restrictiveness and discipline to comply with and exalt restraint. Mercury in detriment. The intellect stymied by severe restraints tends to anxiety and restlessness.

3 - Discovery. Uranus exalted. A genius for the unusual. The ability to discover valuable information in detail work and to find innovative applications for this knowledge. Venus in detriment. A dissatisfaction with the monotony of detail work, where what is missed may be of great importance and value.

4 - Asceticism. Venus exalted. The perfected ascetic withdrawal in the pursuit of harmony and simplicity, where outside dangers do not exist, and there is time to pursue inner meaning in detail. Pluto in detriment. The urge to take action against established values that when restrained by circumstances, leads to withdrawal that waits for opportunity.

5 - Metamorphosis. When excellence is achieved, action is necessary. The Moon exalted. The reaching out to others to share, symbolized by the Moon's phases as it moves from darkness to eventually sharing fully its light. Neptune in detriment. A tendency in metamorphosis to seek acclaim through dramatic presentation.

6 - Self-discipline. Saturn exalted. A penny saved is a penny earned. Detail as the path to material success. Mercury in detriment. The skills but not the discipline to succeed.

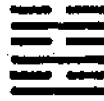
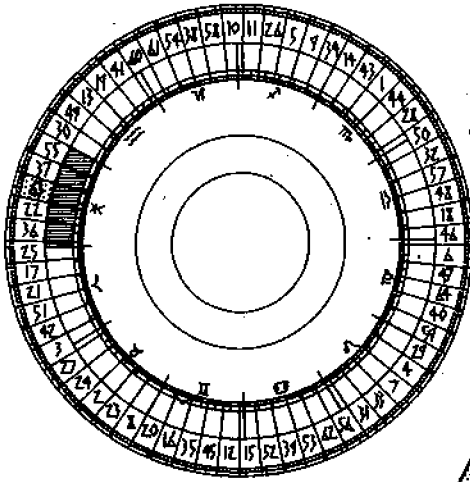

After Completion

11°22'30'' - 17°00'00'' ✕

The Lines

- 1-11°22'30'' - 12°18'45''
- 2-12°18'45'' - 13°15'00''
- 3-13°15'00'' - 14°11'15''
- 4-14°11'15'' - 15°07'30''
- 5-15°07'30'' - 16°03'45''
- 6-16°03'45'' - 17°00'00''

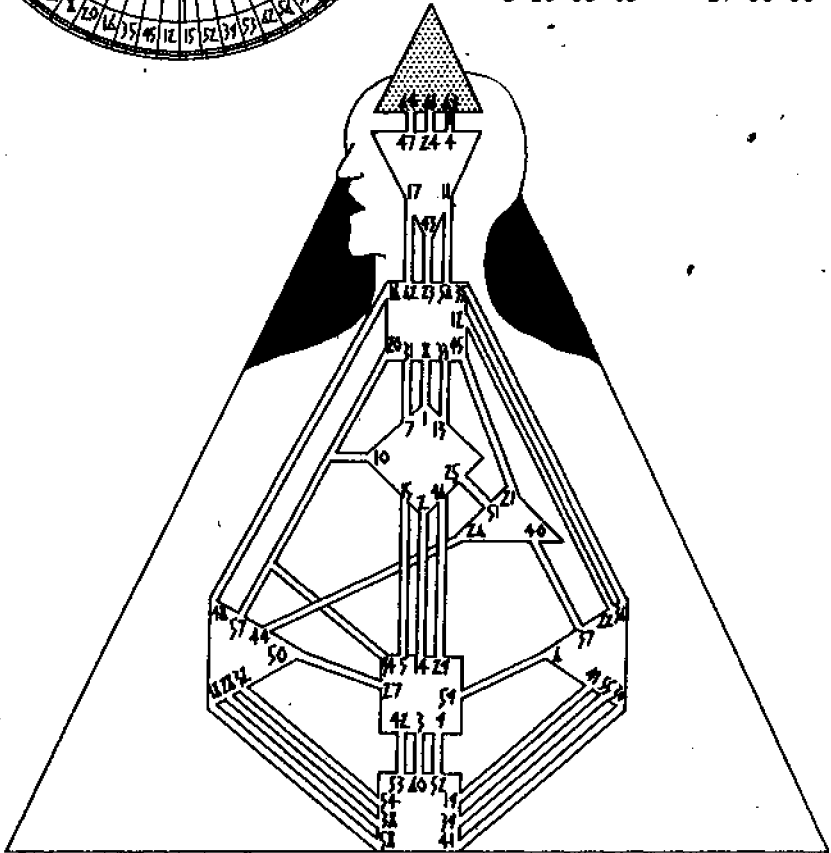

After Completion

Sign: Pieces-Mutable. Openness Devotion Conflict

Center: The Head Center. Inspiration Initiation Undergoing

Biology: The Pineal Gland

Gate: 63 After Completion

Harmonic Gate: 4 Youthful Folly

Channel: 63-4 Logic. A design of mental ease mixed with
doubt

In the spiral of life, all ends are beginnings.

The Lines

1 - Composure. The Sun exalted. The quality of personality where achievement is accepted with equanimity and where continued development is allowed to take its natural course. Mars in detriment. The tendency in achievement to immediately seek new goals at the risk of destabilizing what has already been accomplished.

2 - Structuring. Jupiter exalted. The establishing of a large framework through which achievement can be expanded and shared; compensating others for their contributions while maintaining control of direction. Uranus in detriment. Instability in achievement that when in positions of authority leads to arrogance and the desire to keep others away from the center of power.

3 - Continuance. Jupiter exalted. The dedication to the new beginning that insists on maintaining its achieved principles despite having to interact with those who have not attained such a state. Saturn in detriment. Success at any price.

4 - Memory. Mercury exalted. The detailed accounting of the achievement process whose information base can prepare a new order for the future. Mars in detriment. A willingness to forget in the glow of victory, with a possible price to be paid later.

5 - Affirmation. The Sun exalted. The authority and sincerity of purpose to pursue the same values in the new beginning that had allowed it to transcend the old. Mars in detriment. A tendency in triumph to pay lip service to such values, and given such leadership, these values will be reduced to nothing more than empty rituals.

6 - Nostalgia. Jupiter exalted. The good sense to avoid turning the previous struggle into an obsession. Pluto in detriment. Revolutionary nostalgia.

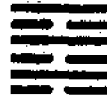
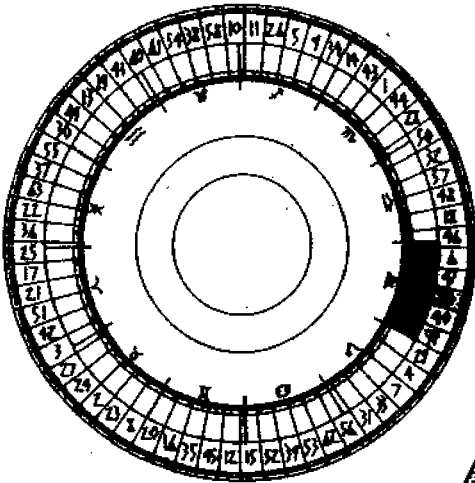

Before Completion

11°22'30" - 17°00'00" 117

The Lines

- 1-11°22'30" - 12°18'45"
- 2-12°18'45" - 13°15'00"
- 3-13°15'00" - 14°11'15"
- 4-14°11'15" - 15°07'30"
- 5-15°07'30" - 16°03'45"
- 6-16°03'45" - 17°00'00"

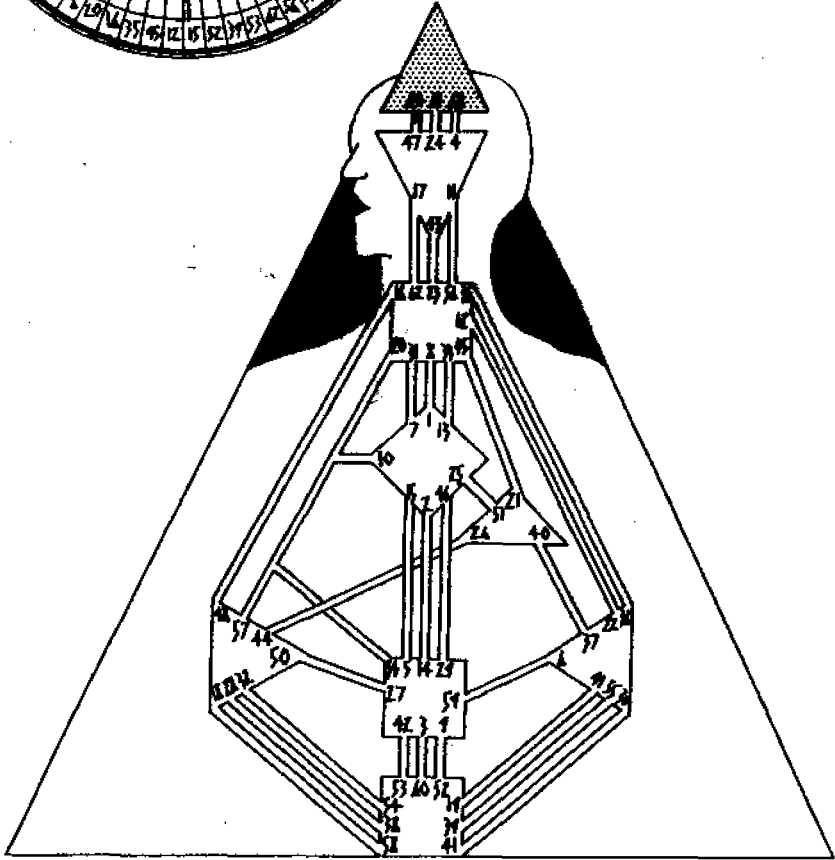

Before Completion

Sign: Virgo-Mutable. Mental detail Service Judgmentation
Center: The Head Center. Inspiration Initiation Undergoing
Biology: The Pineal Gland
Gate: 64 Before Completion
Harmonic Gate: 47 Oppression
Channel: 64-47 Abstraction. A design of mental activity and clarity

Transition, like birth, requires a determined strength for the passage through.

The Lines

1 - Conditions. Venus exalted. In penetrating to the center, the understanding that instills the necessary harmony to survive disorder. Mars in detriment. The powerful temptation when having transition in sight, to hasty action.

2 - Qualification. Venus exalted. An inner development which recognizes what qualities are essential for transcendence and the awareness that without them, action will fail. The Moon in detriment. Constantly in action, it wastes the very qualities and resources that it will need.

3 - Overextension. Saturn exalted. The wisdom to recognize when one has not the necessary resources to complete transition. Such timely awareness may give it a chance to seek assistance. The Moon in detriment. The risk of a superficially confident personality that when transition collapses, there is no one to turn to.

4 - Conviction. The Moon exalted. Symbolized by its phases, the Moon is assured of transition convinced by its very process that it will triumph. Mars in detriment. Where force and energy alone cannot overcome doubt.

5 - Promise. Venus exalted. The values promised in any new order are demonstrated through harmonic interactions with others. This strengthens the justification for the struggle. Jupiter in detriment. A tendency in trying to justify the struggle by focusing exclusively on the failure of the old order that cannot demonstrate the quality of the new.

6 - Victory. Mercury exalted. The mental assuredness, that knew that victory was inevitable, thus making triumph sweet but not reason for excess. Venus in detriment. Like the story of the Trojan Horse, it can be dangerous to get carried away in celebration, least one loses vigilance and perspective.

THE JUXTAPOSITION UNIFIED THEORY (JUT)

The theoretical basis of the Human Design System



The Wind and Thunder reinforce each other. The Superior man reinforces his good traits and not his bad ones.

4 - x - The Man keeps to the mean. The Prince follows his advice. He can be relied on for important things. Even relocating the Capital.

The Book of Changes. 42 Increase

The expansion of resources which maximizes the development of full potential.

4 - x - The middle man. The quintessential manifestation of the mediator.

The Rave I Ching. 42 Increase

Part One

IT'S A MATTER OF TIME

There is a tendency in Man to accept the prevailing absolutes of the scientific community. It should be remembered that these absolutes have always tended to be transitory; Newton's Laws being the best example.

Albert Einstein recognized that without a theoretical understanding of the beginning, no Law could be substantiated as an absolute. Without a mathematical key to Singularity, all theories are relegated to Laws of Perspective, where these concepts apply to only specific conditions. Thus, Einstein's life-long search and Quantum Mechanics' search for a Unified Field Theory.

In the introduction to the Human Design System, it is stated that the event we call the 'Big Bang', was initiated by impact. This statement is at odds with both Relativity and Quantum. These theories are predicated on a spontaneous creation. For Einstein, a deeply spiritual man, the ramifications of Relativity were disturbing. If, as his famous equation $E=mc^2$ postulated, Time is a dimension born of the Big Bang, then nothing could have existed before, nothing. No unified theory exists to explain how Einstein's four-dimensional universe came into being.

The Juxtaposition Unified Theory (JUT) states that there are five dimensions, and that Time is not one of them; that our universe began 'on Time'.

What science presently knows, is what was produced at the birth of the universe (Big Bang), and not how it was

initiated. We know that at the moment of initiation, the entire mass of our universe was compressed into an object the size of a human fist! The release of this object's energy brought our universe into being.

Though Einstein's Law of Relativity breaks down at Singularity (the pre-Big-Bang state), it does predict the behaviour of the expanding universe accurately. Just as Newton's Laws of Mechanics are relative to the Earth, Einstein's Relativity applies only to the post-Big-Bang conditions. These conditions were based on the relationship between energy and matter in an expanding universe. Einstein focused his attention on this expansion. He postulated that the speed of Light was a constant in the universe (later proven). In the famous Relativity formula, it is stated that Energy (E) equals (=) Matter (m) times the Speed of Light (c) multiplied by itself (²); i.e. $E=mc^2$. This is the basis of the four-dimensional universe, where energy and matter operate in a Space/Time continuum.

For Einstein time and movement were the same, that is that time was unidirectional. He was able to show that since the universe is expanding in all directions at a constant speed and that light bends, the result is the emergence of a relative space. In other words, space and time are interdependent.

Einstein's four-dimensional universe and his concept of time are in the end dependent on the nature of light. However, light as we know it came into existence after the Big Bang. In the pre-Big-Bang state there was no light. If there was no light, there was no constant to measure; Relativity is

then meaningless. Einstein did not know where the light came from; he was not alone.

The Juxtaposition Unified Theory (JUT) begins with the premise that at Singularity (the pre-Big-Bang state) $c=E$, that the Speed of Light is equal to Energy.

The heart of the JUT is the presumption that the universe was created. We have been given a picture by science of a universe at singularity compressed to the size of an egg, an appropriate metaphor. Such objects exist in our universe on a different scale. We call them Black Holes. When these objects are subjected to a great enough impact they release their energy. When the expansion of this energy is slowed by eventual cooling, the materials coalesce into stars.

Impact is a law of the universe, what applies to black holes in general, is archetypal at singularity. In the beginning, before the start, was a Black Hole, waiting, in its Time. Something 'banged' into it and created as a result of the impact our five-dimensional universe:

- | | | |
|--------|-----------|----------------------|
| One. | Being | Being is Matter |
| Two. | Movement | Movement is Energy |
| Three. | Space | Space is Form |
| Four. | Design | Design is Structure |
| Five. | Evolution | Evolution is Gravity |

These five dimensions, which will be discussed in detail as we progress, did not exist at singularity. Singularity is a Duality: the universe is a dualistic system by design, and so is Homo Sapiens.

In the beginning we have the 'egg', black hole, its nature

was Being/Design, i.e. the structure of matter (m) and the 'seed', the dualistic Yang to the egg's Yin. Its nature was Movement/Space/Evolution, i.e. the Energy to Evolve Form (E). The premise of the JUT is that Einstein's Relativity formula can be applied to the pre-Big-Bang state, Singularity, by equating the speed of light with energy:

$$E = m c^2$$

$$\text{if } c = E$$

$$\text{then } E = m E^2$$

In terms of the JUT, the formula is illustrated in two sections. First is the pre-singularity state, followed by singularity:

$$E \rightarrow M / E \cdot ME^{\diamond}$$

The symbol \diamond , the Juxtapose, embraces the idea of squaring, doubling, but as we understand it in genetics. Not multiplication, but replication, positive and negative, form and mask, less a matter of mathematics than Design. The Design duality.

In the Human Design System, humankind is described as being endowed with two Crystals of Consciousness and a Magnetic Monopole. The Design Crystal, manifesting the biochemical vehicle, and the Personality Crystal, manifesting the experiential awareness, and the Magnetic Monopole manifesting the individual geometry. This trinity has its basis in the original duality,

$$E \rightarrow M$$

We have two objects in a void. There is the Yin black hole and a Yang object. The Yang seed is a crystal, its potential is Space/Evolution (E). At the core of the Yang crystal is a magnetic source. As the entire mass of the universe was compressed into the Yin black hole, the entire magnetic capacity of the universe was present in the core of the Yang crystal. Its potential is Movement (M).

The Yin egg is a matter shell with a crystal core. Its potential is Being/Design (M).

In the beginning before the start, the Yang magnetism and the Yin mass were mutually attractive. At impact, singularity, the 2 became 4. The Yang crystal shattered as the magnetic core cracked the matter shell, shattering the Design crystal core. Four dimensional fields, their potentials existed at impact, followed by the expansion of the universe and the appearance of the fifth dimension, Space.

Since the emergence of space is relative and is dependent on the existence of light, we can answer the question of where the light came from by examining the four dimensions of singularity, $E = ME^4$.

Every human being is endowed with a Personality Crystal and a Magnetic Monopole. The shattering of the Yang object at impact resulted in two dimensional fields. The Dimension of Movement, that is both manifested and experienced through the Magnetic Monopole - in a human being, this is experienced as Individuality; and the Dimension of Evolution, that is both manifested and experienced through the Personality Crystal - in a human being, this is experienced as Mind.

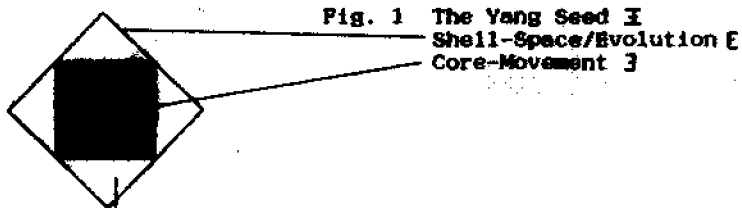
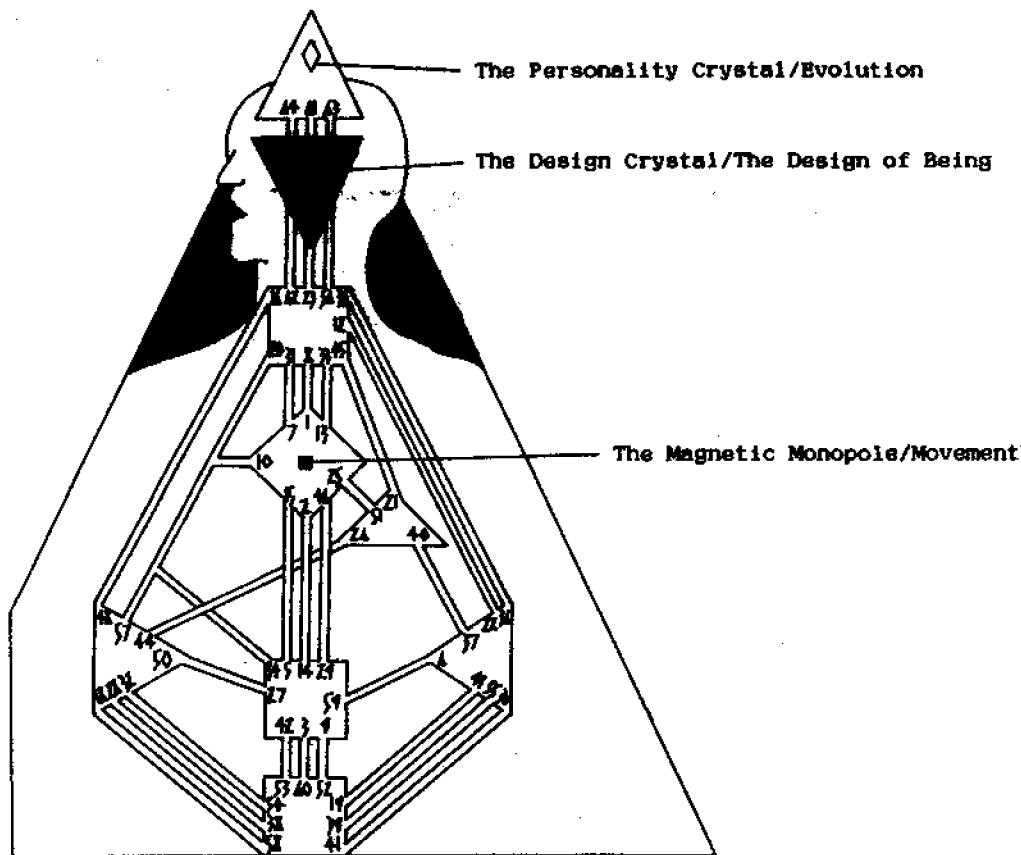

Fig.3 Human Design



Every human being is of matter and is endowed with a Design Crystal. The shattering on impact released two dimensional fields. The Dimension of Being, manifested and experienced through Matter - in a human being, this is experienced as the Body; and the Dimension of Design, manifested and experienced through the Design Crystal - in a human being, this is experienced as the Ego.

Dimension		Nature	Basic Component
Movement	3	Movement is Energy Energy is Creation Creation is Seeing Seeing is Landscape Landscape is Environment	Magnetic Monopole
Evolution	E	Evolution is Gravity Gravity is Memory Memory is Taste Taste is Love Love is Light	Personality Crystal
Being	M	Being is Matter Matter is Matter is Touch Touch is Sex Sex is Survival	The Atom
Design	◆	Design is Structure Structure is Progress Progress is Smelt Smelling is Life Life is Art	Design Crystal

As can be seen in the Four Dimension chart, light is a property of the dimension of evolution.

In our picture of the pre-Big-Bang environment, we have two mutually attractive objects approaching each other. Since each object was moving, and the resulting collision released incredible amounts of matter and energy, it can be assumed that the relative speed of these objects was considerable. When the Yang banged into the Yin, it not only ended the

inertia of Being/Design, it initiated movement and the expansion of the universe, and the emergence of Light in the dimension of Space.

Now we can look at how the JUT formula transforms into Relativity after the Big Bang. In doing so we can clear up the matter of Time.

We have three conditions:

1. The pre-Big-Bang state. The void $\Xi \rightarrow M$

Ξ The Yang - the Energy to Evolve Form

M The Yin - the Structure of Matter

2. Singularity. Contact. The Four Dimensions $\exists = ME^\diamond$

\exists Energy - the dimension of Movement. Magnetic Monopole

M Matter - the dimension of Being. Quarks

E Gravity - the dimension of Evolution. Personality Crystal

\diamond Structure - the dimension of Design. Design Crystal

3. The post-Big-Bang state. Five-dimensional Relativity $\exists = M \langle \lambda$

\exists Energy - the dimension of Movement. Magnetic Monopole

M Matter - the dimension of Being. Atomic

\langle Light - the dimension of Evolution. Personality Crystal

λ Progress - the dimension of Design. Design Crystal

You will note that Space does not play a part in these formulae. Space is a condition resulting from the interaction of the four dimensional fields, and is not a contributing component.

Dimension	Nature	Basic Component
Space	Space is Form Form is Illusion Illusion is Hearing Hearing is Music Music is Freedom	Personality Crystal

The dimension of Space on a human level is experienced through the Personality Crystal as Presence. It is the relative expression of the personality.

One can see, that based on the JUT mathematical expression the transformation from Singularity to Relativity can be accomplished by redefining what Einstein called Time. In Relativity's $E=mc^2$ we have energy, matter and light. There is no formula without the squaring (2) of light's speed. It is the squaring that initiates Time. We have seen that in the JUT, this function is fulfilled by the dimension of Design (\diamond). What Einstein called Time, can be the same by any other name. Structure and progression, this is the very nature of the dimension of Design. Time on the other hand is a continuum. Creation happened in Time.

Part Two

IT'S A MATTER OF DESIGN

In a created universe, we have seen that time is not a dimension, but design is. Einstein, in fact, was partially right, in that he understood that there were four dimensions. The universe is a four-dimensional field, the 'fifth', Space, is the result of the interplay of the others. As such, it is an illusion and it is this illusion manifested in humans as personality, that has defined our lives and purpose.

It is the premise of the Human Design System, that the universe is a single living entity; that this entity, the Child came into being when the Yin Egg was fertilized by the Yang Seed at Singularity. A duality manifesting outward through replication, both Yin and Yang and neither, the Tao, becoming.

At singularity the 2 became 4. We have seen this dimensionally; now, we can look at the physics. Released by the Yang at impact, the Electron and the Magnetic Monopole. Released by the Yin at impact, the Quarks and the Neutrinos. These are the basic components that sustain the nature of the universe. When 2 became 4, entirely new relationships result. The Yin Quarks and the Yang Electron form a polarity union and the atom, our world of stars and trees and human beings becomes possible.

The Yin Neutrino is the most abundant particle released at the Big Bang. There are nine times more Neutrinos than everything else put together. Neutrinos are also manufactured in stars and three trillion (3,000,000,000,000) pass through

everything, everywhere, all the time, at the speed of light! The Neutrino is the structure of the universe. The Neutrinos form a vast grid/web matrix, in which and through which, everything is connected.

The Yang Magnetic Monopole - it only attracts - rides the Neutrino stream, like a streetcar connecting to an overhead wire. In this analogy, the connecting rod of the streetcar is the monopole, the streetcar itself is evolving matter. In other words, the gravitational field of the atom attracts a monopole, and the monopole connects the atom to the Neutrino geometry.

When 2 becomes 4

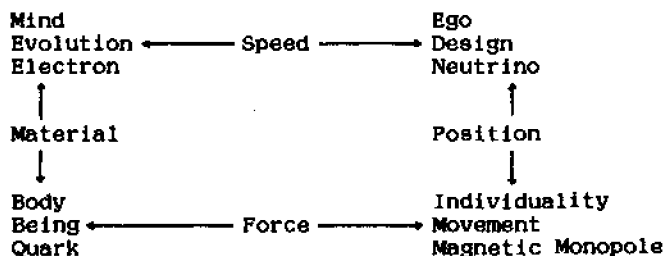

In the Human Design System, a human being is described as being endowed with two Crystals of Consciousness and a Prime Magnetic Monopole. The Personality Crystal - the Mind; the Design Crystal - the Ego Body; and the Magnetic Monopole - the Individuality. The Neutrino is both hardware and software. It is the inter-connector, but it also informs. The Neutrino has mass, and as it passes through the Crystals, it leaves off information. These Crystals are facets resulting from the shattering at impact of the original two. Each facet is unique. In the metaphor of crystal is the ex-

Part Two

IT'S A MATTER OF DESIGN

In a created universe, we have seen that time is not a dimension, but design is. Einstein, in fact, was partially right, in that he understood that there were four dimensions. The universe is a four-dimensional field, the 'fifth', Space, is the result of the interplay of the others. As such, it is an illusion and it is this illusion manifested in humans as personality, that has defined our lives and purpose.

It is the premise of the Human Design System, that the universe is a single living entity; that this entity, the Child came into being when the Yin Egg was fertilized by the Yang Seed at Singularity. A duality manifesting outward through replication, both Yin and Yang and neither, the Tao, becoming.

At singularity the 2 became 4. We have seen this dimensionally; now, we can look at the physics. Released by the Yang at impact, the Electron and the Magnetic Monopole. Released by the Yin at impact, the Quarks and the Neutrinos. These are the basic components that sustain the nature of the universe. When 2 became 4, entirely new relationships result. The Yin Quarks and the Yang Electron form a polarity union and the atom, our world of stars and trees and human beings becomes possible.

The Yin Neutrino is the most abundant particle released at the Big Bang. There are nine times more Neutrinos than everything else put together. Neutrinos are also manufactured in stars and three trillion (3,000,000,000,000) pass through

everything, everywhere, all the time, at the speed of light! The Neutrino is the structure of the universe. The Neutrinos form a vast grid/web matrix, in which and through which, everything is connected.

The Yang Magnetic Monopole - it only attracts - rides the Neutrino stream, like a streetcar connecting to an overhead wire. In this analogy, the connecting rod of the streetcar is the monopole, the streetcar itself is evolving matter. In other words, the gravitational field of the atom attracts a monopole, and the monopole connects the atom to the Neutrino geometry.

When 2 becomes 4

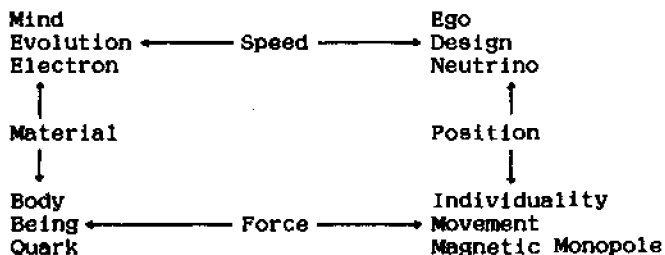

In the Human Design System, a human being is described as being endowed with two Crystals of Consciousness and a Prime Magnetic Monopole. The Personality Crystal - the Mind; the Design Crystal - the Ego Body; and the Magnetic Monopole - the Individuality. The Neutrino is both hardware and software. It is the inter-connector, but it also informs. The Neutrino has mass, and as it passes through the Crystals, it leaves off information. These Crystals are facets resulting from the shattering at impact of the original two. Each facet is unique. In the metaphor of crystal is the ex-

pression of a fundamental idea in Human Design, that different crystals will manifest the same light differently. In humankind, these crystal facets translate the same Neutrino feed differently.

In a created universe, where the whole is always greater than the sum of the parts, it would be folly to assume independent will. Yet human will has been exalted to the point of obsession. This delusion is also quite natural. We are part of an evolving duality. On our scale, there are really only two realities; what is and how it is perceived. There is no choice, the physical evidence is irrefutable, and there is choice, the perception of the personality.

The perception of the personality cannot be substantiated, it is an illusion. Yet, everyone knows the power of this illusion. The illustration below shows the source of this power.

When 4 is 5

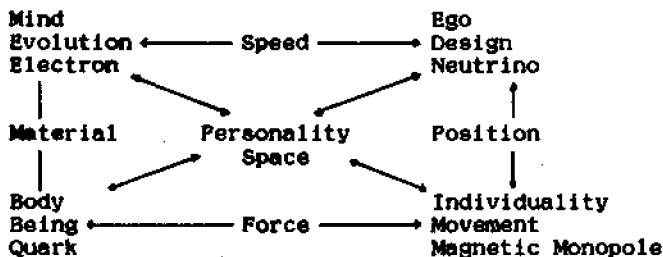

The dimension of Space exists through the interplay of the other four dimensions. In humankind, the personality is an expression of the interplay of the four Human Dimensions of Mind, Ego, Body and Individuality, but like Space, in and of itself, personality has no substance.

In Part One, we looked at the Five Dimensions and their natures. Below is a graph of the dimensions and how they manifest in humanity. In the following pages, we will see how we can apply this information to better understanding ourselves.

Macrocosmic/The Universe		Microcosmic/Humanity		
Dimension	Nature	Dimension	Nature	Keynote
Movement	Movement is Energy Energy is Creation Creation is Seeing Seeing is Landscape Landscape is Environment	Individuality	Activity Reaction Limitation Perspective Relation	Uniqueness I Define
Evolution	Evolution is Gravity Gravity is Memory Memory is Taste Taste is Love Love is Light	The Mind	Character Separation Nature Integration Spirit	Role I Remember
Being	Being is Matter Matter is Matter is Touch Touch is Sex Sex is Survival	The Body	Biology Chemistry Objectivity Geometry Trajectory	Genetics I am
Design	Design is Structure Structure is Progress Progress is Smell Smelling is Life Life is Art	The Ego	Homo Sapiens Growth Decay Continuity Manifestation	Self I Design
Space	Space is Form Form is Illusion Illusion is Hearing Hearing is Music Music is Freedom	Personality	Type Fantasy Subjectivity Rhythm Timing	Presence I Think

what defines us as unique. The Body Graph is based on the combined information of the other two wheels, through the medium of the 64 hexagrams of the I Ching.

The background to the Rave Chart and its mechanics are discussed in detail in the introduction to the Human Design System, the purpose here is to show how the Juxtaposition Unified Theory can be used as an interpretative base in Rave Chart analysis.

Below is an example of a Human Design System Rave Chart.

The Body Graph

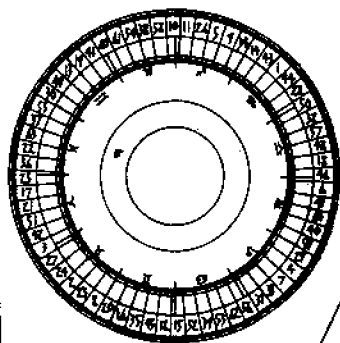

The Wheel of the Design Crystal

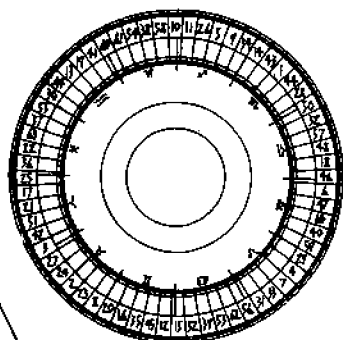

The Wheel of the Personality Crystal

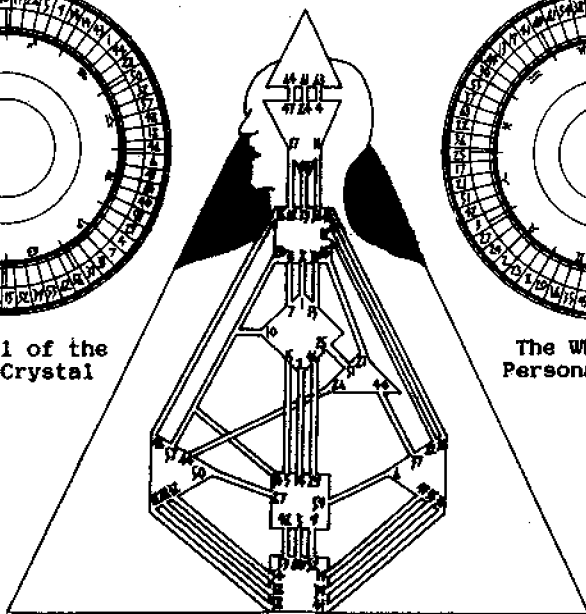

Each of the three components of the Rave have their own values. The Wheel of Design embodies the dimensions of Design and Being. The Wheel of the Personality embodies the dimensions of Evolution and Space. The Body Graph, the synthetic field, embodies the dimension of Movement. Below is a series of Graphs to illustrate each component.

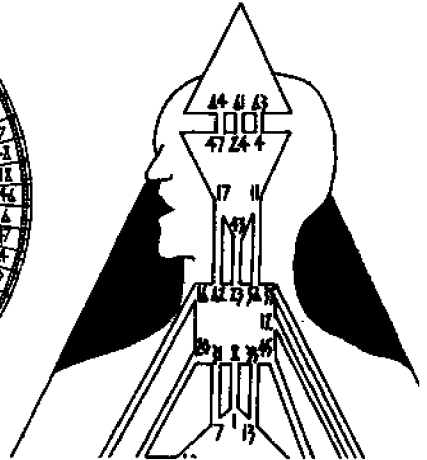
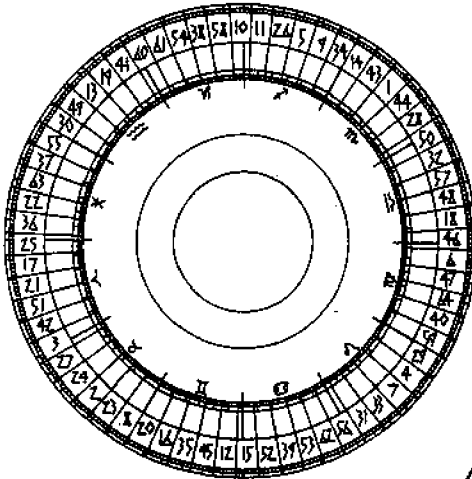

The Wheel of Design

Being/Design

Body/Ego

Genetics I am

The Self I design

Biology/Matter
 Chemistry/Is
 Objectivity/Touch
 Geometry/Sex
 Trajectory/Survival

Homo Saplens/Structure
 Growth/Progress
 Decay/Sense of Smell
 Continuity/Life
 Manifestation/Art

This is the wheel of the physical life. It is how we look and how we feel. It is what we are. This is the design of the vehicle and its process. In analysing the positional data of the Design wheel, only the above dimensions form the parameters for interpretation.

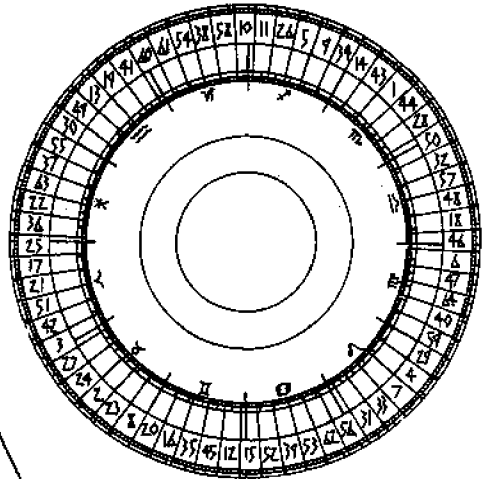
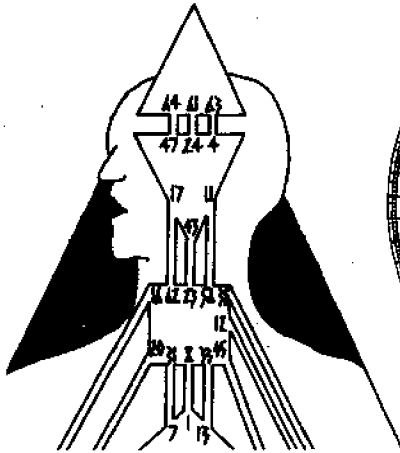

The Wheel of Personality Evolution/Space Mind/Personality

Role I Remember

Presence I Think

**Character/Gravity
Separation/Memory
Nature/Taste
Integration/Love
Spirit/Light**

**Type/Form
Fantasy/Illusion
Subjectivity/Hearing
Rhythm/Music
Timing/Freedom**

This is the wheel of the Witness. It is the experiential awareness. This is the Mind, its reality and its illusion. In analyzing the positional data of the Personality wheel, only the dimensions of Mind/Personality form the basis for interpretation. (It will be noted that since the calculation for this wheel is the same as a traditional astrological chart, it puts the interpretative potential of these charts in perspective.

The relationship between these wheels can best be expressed through the example of the limousine. The Design wheel is the vehicle. The passenger in the back seat is the Personality wheel. The integrator between the vehicle, the

body and the passenger, the Mind/Personality, is the driver,
in the Rave, the Body Graph, the dimension of Movement,
Individuality. It is in the end, where we are, that makes us
unique.

The Body Graph Movement Individuality

Uniqueness I Define

Activity/Energy
Reaction/Creation
Limitation/Seeing
Perspective/Landscape
Relation/Environment

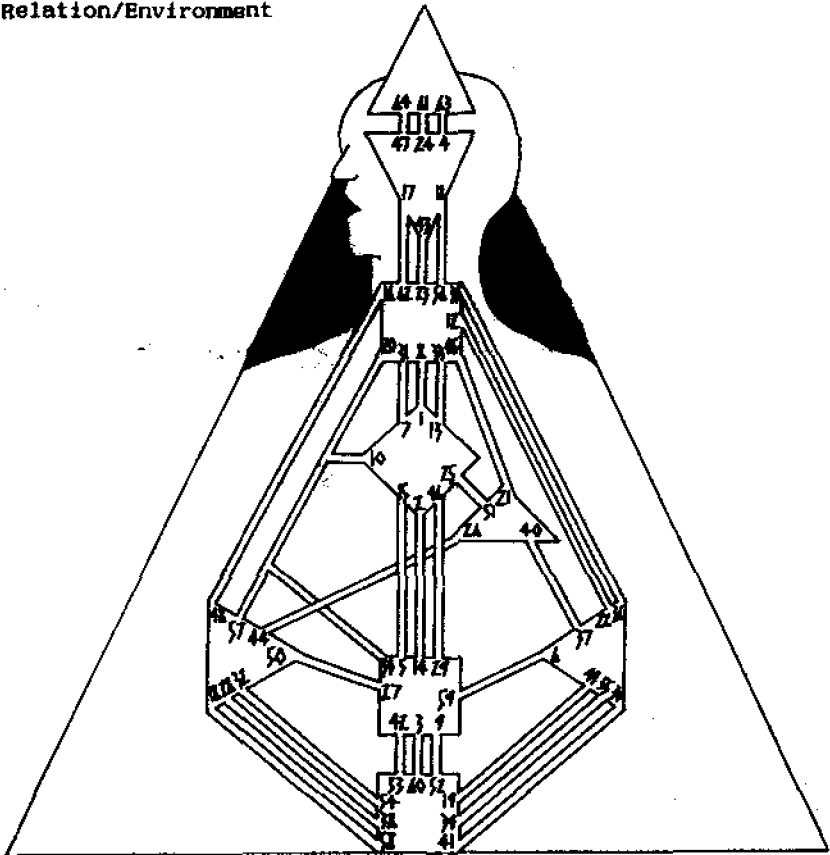

Let's take a look at how this knowledge operates in practice. We will simplify the matter by examining a single gate in the Human Design System Rave. In this case, the 16th gate.

16 Enthusiasm (05°45'00'' - 11°22'30' II)

Sign: Gemini-Mutable. Changeability Duality Expansion

Center: Throat. Action Metamorphosis Unfolding

Biology: The Thyroid and Parathyroid Glands

Harmonic Gate: 48 The Well

Channel: 16-48 The Wave Length. A design of talent

The great art of enriching life by the harmonic channelling of energy.

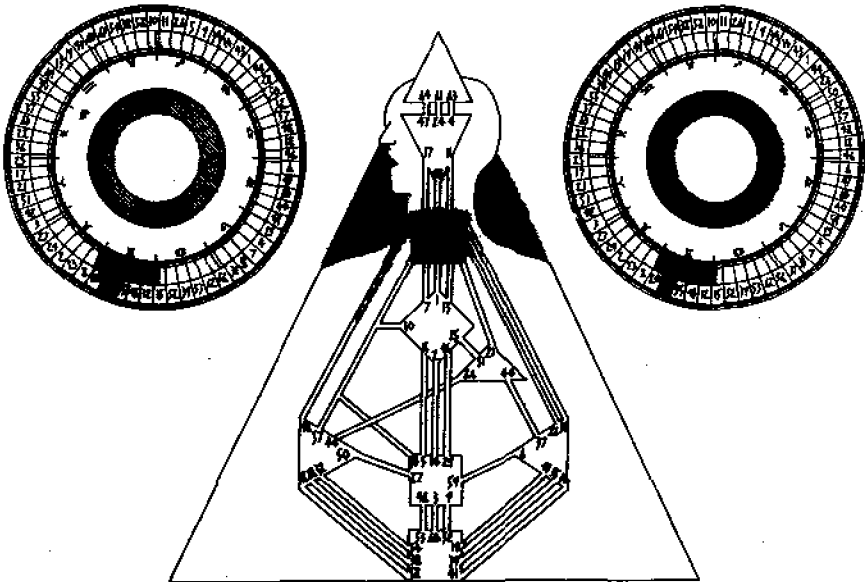

Traditionally the 16th gate is the hexagram of music. We know from our previous analysis, that music is an aspect of the dimension of space, in humans the personality. If we use a five-dimensional graph, we can see the interplay that is manifested as music. We can also identify their source, i.e. the Design Wheel (DW), the Personality Wheel (PW), and the Body Graph (BG).

When the 5 is a Song

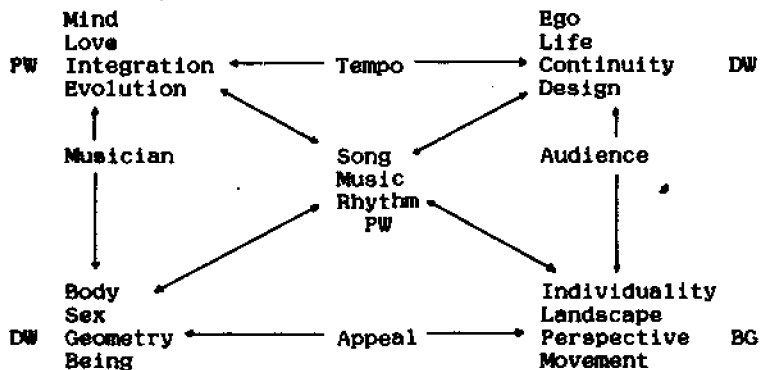

To begin with, an individual that has both of the 16th gates opened in their design, would experience music as a major component of their lives. This musical potential, since it embraces all the dimensional fields, will then be conditioned by the nature of the planets that open the gates, and whether or not the complete channel is connected. It is when a gate is opened from one wheel only that the above information plays its most important role.

For the purposes of this exercise, let's assume that the 16th gate is opened from the Design Wheel only. If we relate this to the graph above, we see a very different picture. (It should be remembered here, that the Magnetic Monopole,

through the Body Graph is a constant.) Without the dimensions of the Personality Wheel, we have a totally different base for interpreting this gate opening.

When there is only 3 of the 5

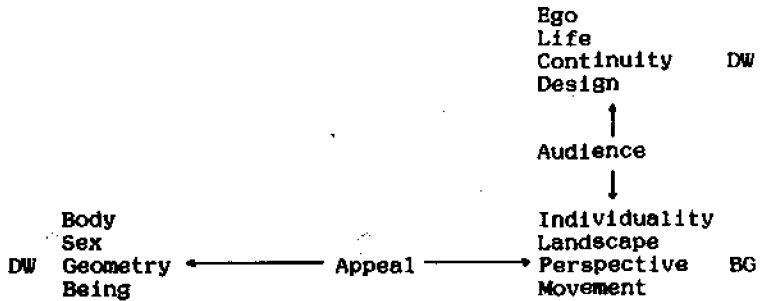

Without an opening from the Personality Wheel, the role of musician no longer exists. However, the opening in the Design Wheel translates as an opening in the Body Graph. The graph expresses our individuality. One does not have to play or compose music in order to have it as a major aspect of one's life. This is the field of the Body, of the Dance, of receptivity and pleasure.

This is the reason why in the Rave Charts, the opening of gates in the Body Graph is colour coded to the wheel from which it derives.

When there is only 3 of the 5

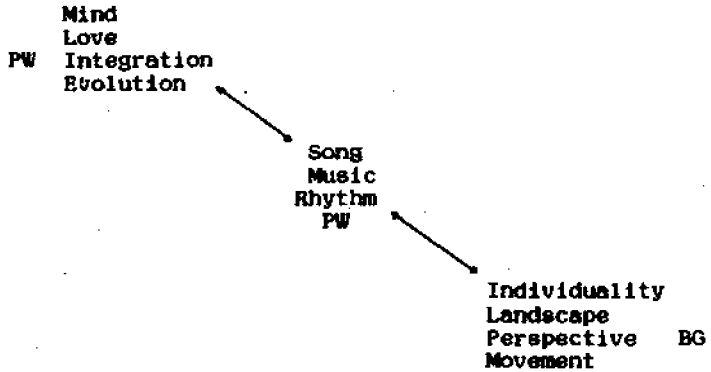

Without the opening from the Design Wheel, we have the creative potential without the medium, a singer without a voice.

In this way, each gate opened in an individual design can be analyzed and put in perspective.

It is an irony, that for the reality of the first darkness, there had to be light.

The Mother alone, great Yin/Yin that she is, could only not be in her frozen stillness.

For all the horror that is the mark of the Yang/Yang, its first act engendered being.

Between then and now the momentum has spawned our vast universal diversity. That parental light diffused as it is throughout matter fosters both our separateness and our yearning to be one again. Do not fear the darkness. Light cannot exist without it. The Tao is neither Yin nor Yang. It is more than its parts. The Devil and Krist as one are neither.

Wait and see. When the Change comes, the awareness of what it all means will generate a laughter that will shake the belly of the Mother.

You have no choice.

You are unique.

Love yourself.

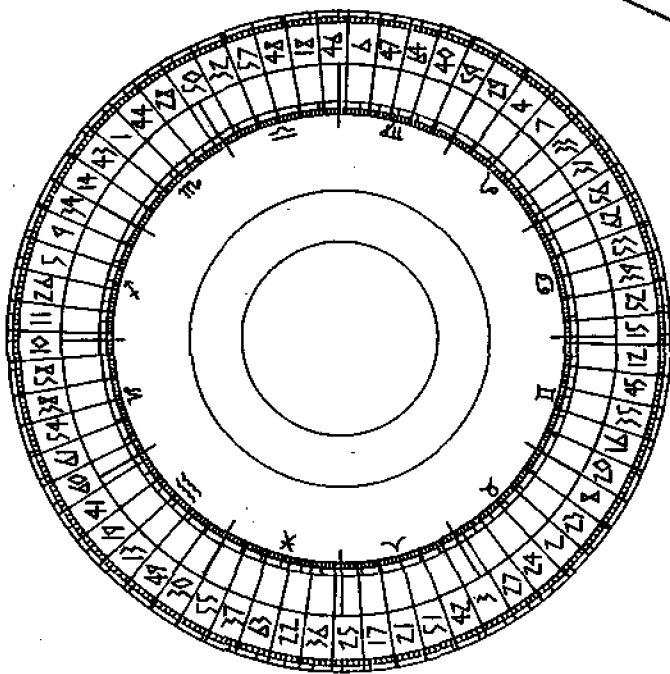
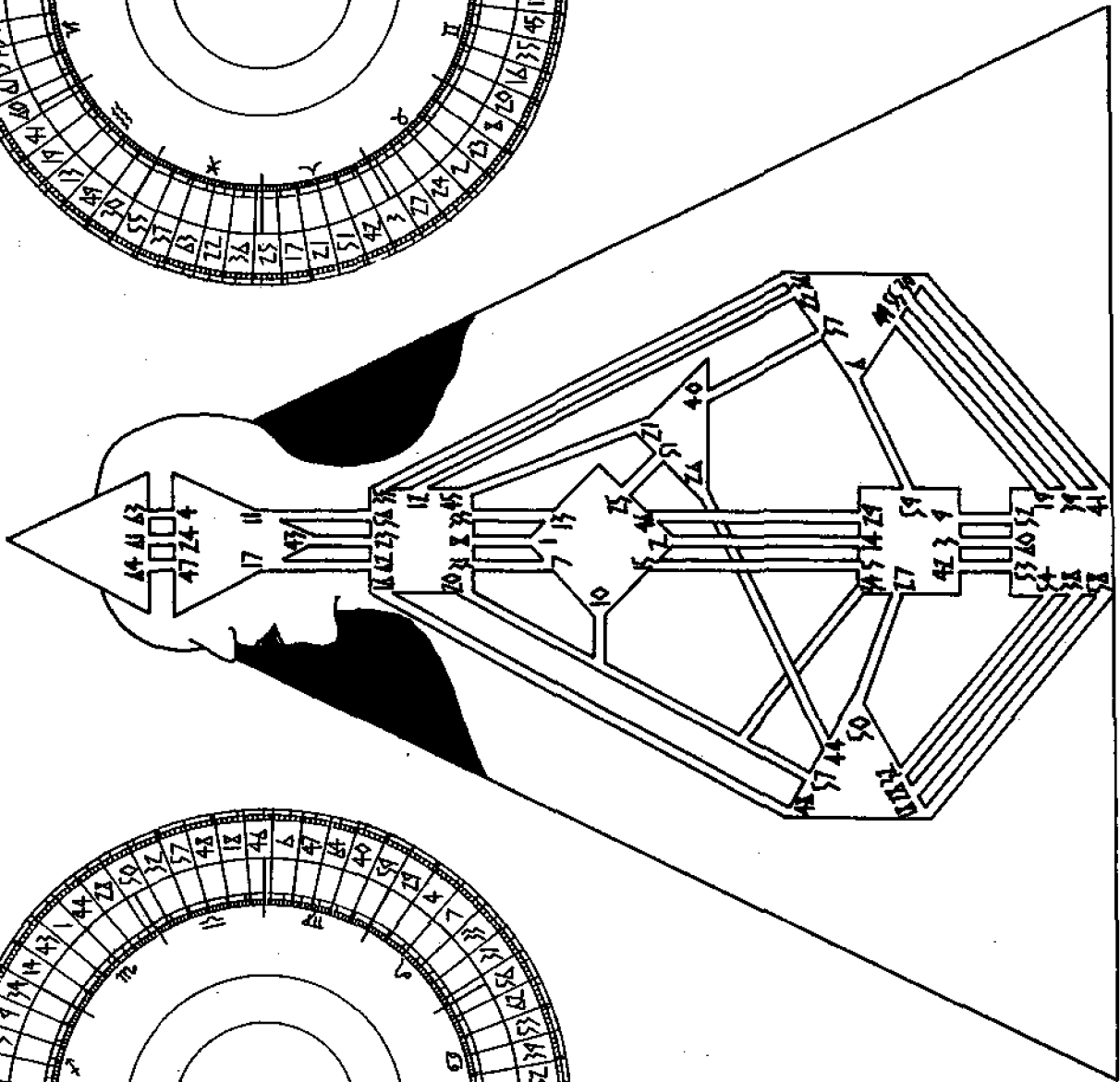
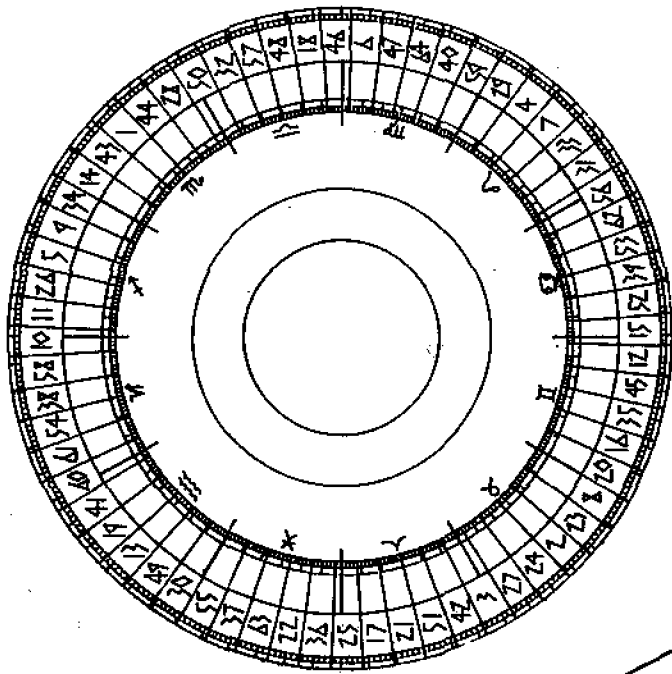

Design

Personality

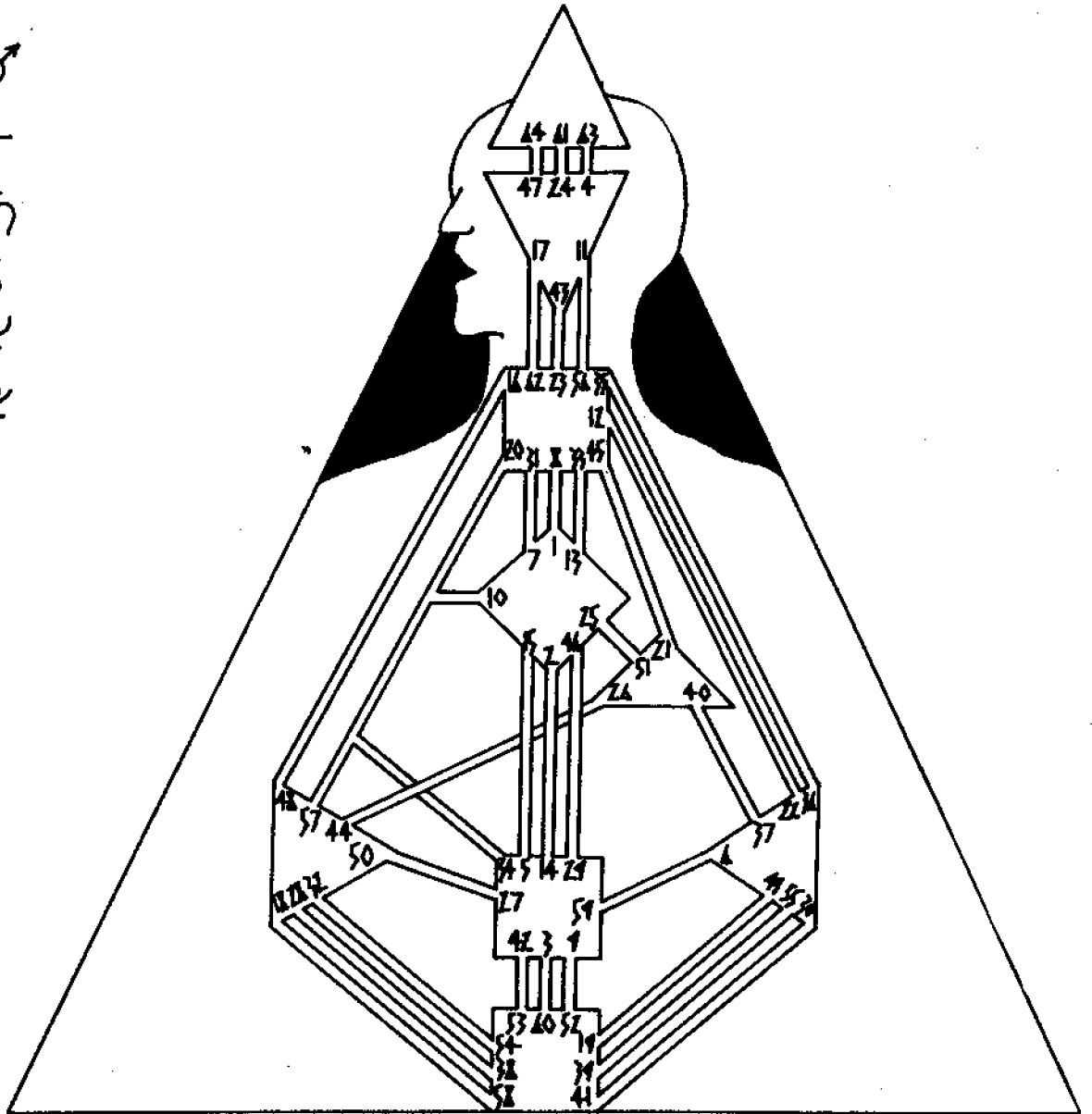

RAVE

Channel and Definition

Analysis Graph

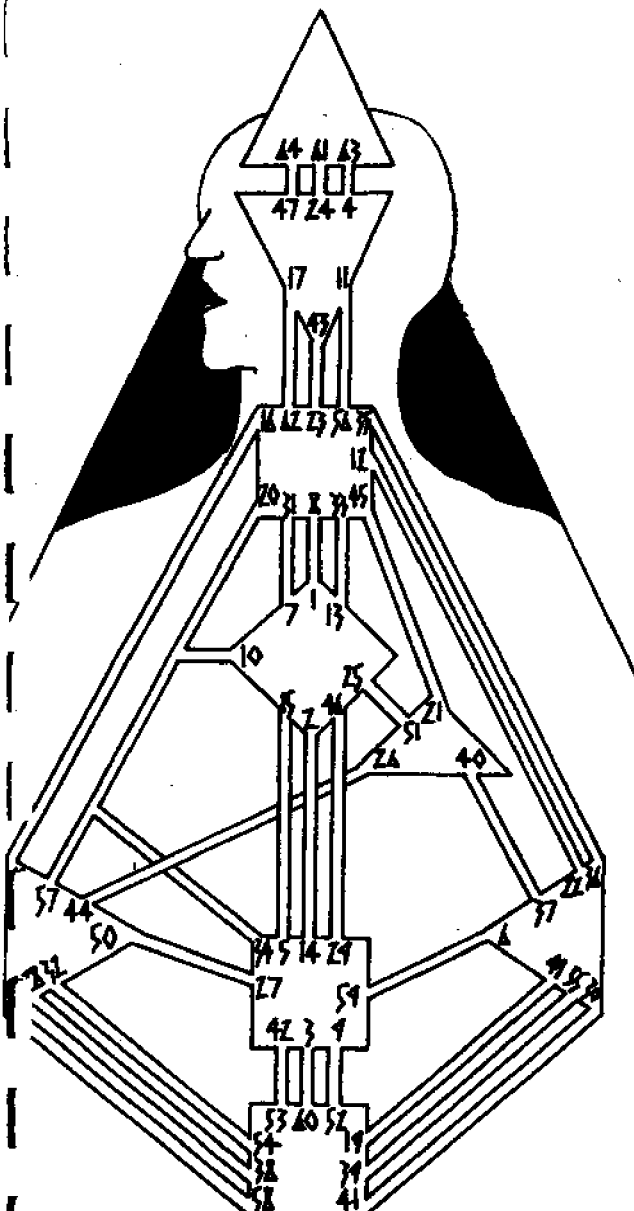

Channel	Hexagrams
Abstraction	64 - 47
Awareness	61 - 24
Logic	63 - 4
Acceptance	17 - 62
Structuring	43 - 23
Curiosity	11 - 56
Awakening	20 - 10
The Alpha	31 - 7
Inspiration	8 - 1
The Prodigal	33 - 13
The Wavelength	16 - 48
The Brain Wave	20 - 57
Charisma	20 - 34
Transitoriness	35 - 36
Openness	12 - 22
Exploration	10 - 34
Rhythm	15 - 5
Beat	2 - 14
Discovery	46 - 29
Perfect Form	10 - 57
Initiation	25 - 51
Community	40 - 37
Surrender	26 - 44
Money	21 - 45
Maturation	42 - 53
Mutation	3 - 60
Concentration	9 - 52
Mating	59 - 6
Power	34 - 57
Preservation	27 - 50
Transformation	32 - 54
Struggle	28 - 38
Judgment	18 - 58
Synthesis	49 - 19
Emoting	55 - 39
Recognition	30 - 41

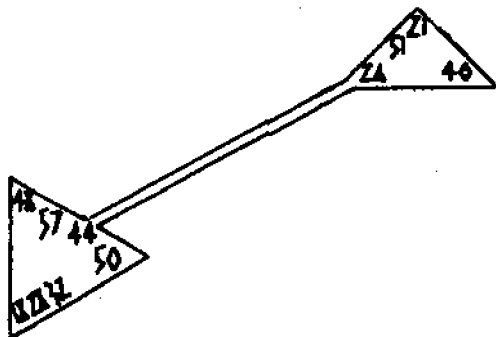

Keynote

- A design of mental activity and clarity
- A design of a thinker
- A design of mental ease mixed with doubt

- A design of an organizational being
- A design of individuality
- A design of a searcher

- A design of commitment to higher principles
- For 'good' or 'bad' a design of leadership
- The creative role model
- The design of a witness

- A design of talent
- A design of penetrating awareness
- A design where thoughts must become deeds

- A design of a 'Jack of all trades'
- A design of a social being

- A design of following one's convictions
- A design of being in the flow
- A design of being the keeper of keys
- A design of succeeding where others fail

- A design for survival

- A design of needing to be first

- A design of being a part seeking a whole
- A design of a transmitter
- A design of a materialist

- A design of balanced development, cyclic
- Energy which fluctuates and initiates, pulse
- A design of determination, focused

- A design focused on reproduction

- A design of an archetype
- A design of custodianship

- A design of being driven
- A design of stubbornness
- A design of insatiability

- A design of being sensitive
- A design of moodiness
- A design of focused energy

